

THE EXPERT'S VOICE® IN PROGRAMMING

Modern X86 Assembly Language Programming

32-bit, 64-bit, SSE, and AVX

Daniel Kusswurm

Apress®

www.it-ebooks.info

For your convenience Apress has placed some of the front matter material after the index. Please use the Bookmarks and Contents at a Glance links to access them.



Contents at a Glance

About the Author	xix
About the Technical Reviewer	xxi
Acknowledgments	xxiii
Introduction	xxv
■ Chapter 1: X86-32 Core Architecture	1
■ Chapter 2: X86-32 Core Programming	27
■ Chapter 3: X87 Floating-Point Unit	87
■ Chapter 4: X87 FPU Programming	103
■ Chapter 5: MMX Technology	133
■ Chapter 6: MMX Technology Programming	147
■ Chapter 7: Streaming SIMD Extensions	179
■ Chapter 8: X86-SSE programming – Scalar Floating-Point	207
■ Chapter 9: X86-SSE Programming – Packed Floating-Point	237
■ Chapter 10: X86-SSE Programming – Packed Integers	273
■ Chapter 11: X86-SSE Programming – Text Strings	303
■ Chapter 12: Advanced Vector Extensions (AVX)	327
■ Chapter 13: X86-AVX Programming - Scalar Floating-Point	351
■ Chapter 14: X86-AVX Programming - Packed Floating-Point	377
■ Chapter 15: X86-AVX Programming - Packed Integers	405

■ Chapter 16: X86-AVX Programming - New Instructions.....	439
■ Chapter 17: X86-64 Core Architecture	491
■ Chapter 18: X86-64 Core Programming	503
■ Chapter 19: X86-64 SIMD Architecture	557
■ Chapter 20: X86-64 SIMD Programming	563
■ Chapter 21: Advanced Topics and Optimization Techniques	623
■ Chapter 22: Advanced Topics Programming	637
Index.....	657

Introduction

Since the invention of the personal computer, software developers have used assembly language to create innovative solutions for a wide variety of algorithmic challenges. During the early days of the PC era, it was common practice to code large portions of a program or complete applications using x86 assembly language. Even as the use of high-level languages such as C, C++, and C# became more prevalent, many software developers continued to employ assembly language to code performance-critical sections of their programs. And while compilers have improved remarkably over the years in terms of generating machine code that is both spatially and temporally efficient, situations still exist where it makes sense for software developers to exploit the benefits of assembly language programming.

The inclusion of single-instruction multiple-data (SIMD) architectures in modern x86 processors provides another reason for the continued interest in assembly language programming. A SIMD-capable processor includes computational resources that facilitate concurrent calculations using multiple data values, which can significantly improve the performance of applications that must deliver real-time responsiveness. SIMD architectures are also well-suited for computationally-intense problem domains such as image processing, audio and video encoding, computer-aided design, computer graphics, and data mining. Unfortunately, many high-level languages and development tools are unable to fully (or even partially) exploit the SIMD capabilities of a modern x86 processor. Assembly language, on the other hand, enables the software developer to take full advantage of a processor's entire computational resource suite.

Modern X86 Assembly Language Programming

Modern X86 Assembly Language Programming is an edifying text on the subject of x86 assembly language programming. Its primary purpose is to teach you how to code functions using x86 assembly language that can be invoked from a high-level language. The book includes informative material that explains the internal architecture of an x86 processor as viewed from the perspective of an application program. It also contains an abundance of sample code that is structured to help you quickly understand x86 assembly language programming and the computational resources of the x86 platform. Major topics of the book include the following:

- X86 32-bit core architecture, data types, internal registers, memory addressing modes, and the basic instruction set
- X87 core architecture, register stack, special purpose registers, floating-point encodings, and instruction set

- MMX technology and the fundamentals of packed integer arithmetic
- Streaming SIMD extensions (SSE) and Advanced Vector Extensions (AVX), including internal registers, packed integer and floating-point arithmetic, and associated instruction sets
- X86 64-bit core architecture, data types, internal registers, memory addressing modes, and the basic instruction set
- 64-bit extensions to SSE and AVX technologies
- X86 microarchitecture and assembly language optimization techniques

Before proceeding I should also explicitly mention some of the topics that are not covered. This book does not examine legacy aspects of x86 assembly language programming such as 16-bit real-mode applications or segmented memory models. Except for a few historical observations and comparisons, all of the discussions and sample code emphasize x86 protected-mode programming using a flat linear memory model. This book does not discuss x86 instructions or architectural features that are managed by operating systems or require elevated privileges. It also doesn't explore how to use x86 assembly language to develop software that is intended for operating systems or device drivers. However, if your ultimate goal is to use x86 assembly language to create software for one of these environments, you will need to thoroughly understand the material presented in this book.

While it is still theoretically possible to write an entire application program using assembly language, the demanding requirements of contemporary software development make such an approach impractical and ill advised. Instead, this book concentrates on creating x86 assembly language modules and functions that are callable from C++. All of the sample code and programming examples presented in this book use Microsoft Visual C++ and Microsoft Macro Assembler. Both of these tools are included with Microsoft's Visual Studio development tool.

Target Audience

The target audience for this book is software developers, including:

- Software developers who are creating application programs for Windows-based platforms and want to learn how to write performance-enhancing algorithms and functions using x86 assembly language.
- Software developers who are creating application programs for non-Windows environments and want to learn x86 assembly language programming.

- Software developers who have a basic understanding of x86 assembly language programming and want to learn how to use the x86's SSE and AVX instruction sets.
- Software developers and computer science students who want or need to gain a better understanding of the x86 platform, including its internal architecture and instruction sets.

The principal audience for *Modern X86 Assembly Language Programming* is Windows software developers since the sample code uses Visual C++ and Microsoft Macro Assembler. It is important to note, however, that this is not a book on how to use the Microsoft development tools. Software developers who are targeting non-Windows platforms also can learn from the book since most of the informative content is organized and communicated independent of any specific operating system. In order to understand the book's subject material and sample code, a background that includes some programming experience using C or C++ will be helpful. Prior experience with Visual Studio or knowledge of a particular Windows API is not a prerequisite to benefit from the book.

Outline of Book

The primary objective of this book is to help you learn x86 assembly language programming. In order to achieve this goal, you must also thoroughly understand the internal architecture and execution environment of an x86 processor. The book's chapters and content are organized with this in mind. The following paragraphs summarize the book's major topics and each chapter's content.

X86-32 Core Architecture—Chapter 1 covers the core architecture of the x86-32 platform. It includes a discussion of the platform's fundamental data types, internal architecture, instruction operands, and memory addressing modes. This chapter also presents an overview of the core x86-32 instruction set. Chapter 2 explains the fundamentals of x86-32 assembly language programming using the core x86-32 instruction set and common programming constructs. All of the sample code discussed in Chapter 2 (and subsequent chapters) is packaged as working programs, which means that you can run, modify, or otherwise experiment with the code in order to enhance your learning experience.

X87 Floating-Point Unit—Chapter 3 surveys the architecture of the x87 floating-point unit (FPU) and includes operational descriptions of the x87 FPU's register stack, control word register, status word register, and instruction set. This chapter also delves into the binary encodings that are used to represent floating-point numbers and certain special values. Chapter 4 contains an assortment of sample code that demonstrates how to perform floating-point calculations using the x87 FPU instruction set. Readers who need to maintain an existing x87 FPU code base or are targeting processors that lack the scalar floating-point capabilities of x86-SSE and x86-AVX (e.g., Intel's Quark) will benefit the most from this chapter.

MMX Technology—Chapter 5 describes the x86's first SIMD extension, which is called MMX technology. It examines the architecture of MMX technology including its register set, operand types, and instruction set. This chapter also discusses a number of related topics, including SIMD processing concepts and the mechanics of packed-

integer arithmetic. Chapter 6 includes sample code that illustrates basic MMX operations, including packed-integer arithmetic (both wraparound and saturated), integer array processing, and how to properly handle transitions between MMX and x87 FPU code.

Streaming SIMD Extensions—Chapter 7 focuses on the architecture of Streaming SIMD Extensions (SSE). X86-SSE adds a new set of 128-bit wide registers to the x86 platform and incorporates several instruction set additions that support computations using packed integers, packed floating-point (both single and double precision), and text strings. Chapter 7 also discusses the scalar floating-point capabilities of x86-SSE, which can be used to both simplify and improve the performance of algorithms that require scalar floating-point arithmetic. Chapters 8 - 11 contain an extensive collection of sample code that highlights use of the x86-SSE instruction set. Included in this chapter are several examples that demonstrate using the packed-integer capabilities of x86-SSE to perform common image-processing tasks, such as histogram construction and pixel thresholding. These chapters also include sample code that illustrates how to use the packed floating-point, scalar floating-point, and text string-processing instructions of x86-SSE.

Advanced Vector Extensions—Chapter 12 explores the x86's most recent SIMD extension, which is called Advanced Vector Extensions (AVX). This chapter explains the x86-AVX execution environment, its data types and register sets, and the new three-operand instruction syntax. It also discusses the data broadcast, gather, and permute capabilities of x86-AVX along with several x86-AVX concomitant extensions, including fused-multiply-add (FMA), half-precision floating-point, and new general-purpose register instructions. Chapters 13 - 16 contain sample code that depicts use of the various x86-AVX computational resources. Examples include using the x86-AVX instruction set with packed integers, packed floating-point, and scalar floating-point operands. These chapters also contain sample code that explicates use of the data broadcast, gather, permute, and FMA instructions.

X86-64 Core Architecture—Chapter 17 peruses the x86-64 platform and includes a discussion of the platform's core architecture, supported data types, general purpose registers, and status flags. It also explains the enhancements made to the x86-32 platform in order to support 64-bit operands and memory addressing. The chapter concludes with a discussion of the x86-64 instruction set, including those instructions that have been deprecated or are no longer available. Chapter 18 explores the fundamentals x86-64 assembly language programming using a variety of sample code. Examples include how to perform integer calculations using operands of various sizes, memory addressing modes, scalar floating-point arithmetic, and common programming constructs. Chapter 18 also explains the calling convention that must be observed in order to invoke an x86-64 assembly language function from C++.

X86-64 SSE and AVX—Chapter 19 describes the enhancements to x86-SSE and x86-AVX that are available on the x86-64 platform. This includes a discussion of the respective execution environments and extended data register sets. Chapter 20 contains sample code that highlights use of the x86-SSE and x86-AVX instruction sets with the x86-64 core architecture.

Advanced Topics—The last two chapters of this book consider advanced topics and optimization techniques related to x86 assembly language programming. Chapter 21 examines key elements of an x86 processor's microarchitecture, including its front-end pipelines, out-of-order execution model, and internal execution units. It also includes a discussion of programming techniques that you can employ to write x86 assembly

language code that is both spatially and temporally efficient. Chapter 22 contains sample code that illustrates several advanced assembly language programming techniques.

Appendices—The final section of the book includes several appendices. Appendix A contains a brief tutorial on how to use Microsoft’s Visual C++ and Macro Assembler. Appendix B summarizes the x86-32 and x86-64 calling conventions that assembly language functions must observe in order to be invoked from a Visual C++ function. Appendix C contains a list of references and resources that you can consult for more information about x86 assembly language programming.

Sample Code Requirements

You can download the sample code for this book from the Apress website at <http://www.apress.com/9781484200650>. The following hardware and software is required to build and run the sample code:

- A PC with an x86 processor that is based on a recent microarchitecture. All of the x86-32, x87 FPU, MMX, and x86-SSE sample code can be executed using a processor based on the Nehalem (or later) microarchitecture. PCs with processors based on earlier microarchitectures also can be used to run many of the sample code programs. The AVX and AVX2 sample code requires a processor based on the Sandy Bridge or Haswell microarchitecture, respectively.
- Microsoft Windows 8.x or Windows 7 with Service Pack 1. A 64-bit version of Windows is required to run the x86-64 sample code.
- Visual Studio Professional 2013 or Visual Studio Express 2013 for Windows Desktop. The Express edition can be freely downloaded from the following Microsoft website: <http://msdn.microsoft.com/en-us/vstudio>. Update 3 is recommended for both Visual Studio editions.

■ **Caution** The primary purpose of the sample code is to elucidate the topics and technologies presented in this book. Minimal attention is given to important software engineering concerns such as robust error handling, security risks, numerical stability, rounding errors, or ill-conditioned functions. You are responsible for addressing these issues should you decide to use any of the sample code in your own programs.

Terminology and Conventions

The following paragraphs define the meaning of common terms and expressions used throughout this book. A *function*, *subroutine*, or *procedure* is a self-contained unit of executable code that accepts zero or more arguments, performs an operation, and optionally returns a value. Functions are typically invoked using the processor's call instruction. A *thread* is the smallest unit of execution that is managed and scheduled by an operating system. A *task* or *process* is a collection of one or more threads that share the same logical memory space. An *application* or *program* is a complete software package that contains at least one task.

The terms *x86-32* and *x86-64* are used respectively to describe 32-bit and 64-bit aspects, resources, or capabilities of a processor; *x86* is employed for features that are common to both 32-bit and 64-bit architectures. The expressions *x86-32 mode* and *x86-64 mode* denote a specific processor execution environment with the primary difference being the latter mode's support of 64-bit registers, operands, and memory addressing. Common capabilities of the x86's SIMD extensions are described using the terms *x86-SSE* for Streaming SIMD Extensions or *x86-AVX* for Advanced Vector Extensions. When discussing aspects or instructions of a specific SIMD enhancement, the original acronyms (e.g., SSE, SSE2, SSE3, SSSE3, SSE4, AVX, and AVX2) are used.

Additional Resources

An extensive set of x86-related documentation is available from both Intel and AMD. Appendix C lists a number of resources that both aspiring and experienced x86 assembly language programmers will find useful. Of all the resources listed Appendix C, the most important tome is Volume 2 of the reference manual entitled *Intel 64 and IA-32 Architectures Software Developer's Manual—Combined Volumes: 1, 2A, 2B, 2C, 3A, 3B and 3C (Order Number: 325462)*. This volume contains comprehensive information for each processor instruction, including detailed operational descriptions, lists of valid operands, affected status flags, and potential exceptions. You are strongly encouraged to consult this documentation when developing your own x86 assembly language functions in order to verify correct instruction usage.

CHAPTER 1



X86-32 Core Architecture

This chapter examines the x86-32 core architecture from the perspective of an application program. I begin with a brief historical overview of the x86 platform in order to provide a frame of reference for subsequent discussions. This is followed by a review of the x86's data types, including fundamental, numeric, and packed types. Next, I delve into the details of the x86-32's internal architecture, including its execution units, general-purpose registers, status flags, instruction operands, and memory addressing modes. The chapter concludes with an overview of the x86-32 instruction set.

Unlike high-level languages such as C and C++, assembly language programming requires the software developer to comprehend certain architectural aspects of the target processor before attempting to write any code. The topics discussed in this chapter will help fulfill this requirement and serve as a foundation for understanding the sample code presented in Chapter 2. This chapter also provides the base material that is necessary to understand the x86-64 core architecture, which is discussed in Chapter 17.

Historical Overview

Before you examine the technical details of the core x86-32 platform, a brief history lesson might be helpful in understanding how the architecture has evolved over the years. In the review that follows, I focus on the noteworthy processors and architectural enhancements that have affected how software developers use x86 assembly language. Readers who are interested in a more comprehensive chronicle of the x86's lineage should consult the resources listed in Appendix C.

The original embodiment of the x86-32 platform was the Intel 80386 microprocessor, which was introduced in 1985. The 80386 extended the architecture of its 16-bit predecessors to include 32-bit wide registers and data types, flat memory model options, a 4 GB logical address space, and paged virtual memory. The 80486 processor improved the performance of the 80386 with the inclusion of on-chip memory caches and optimized instructions. Unlike the 80386 with its separate 80387 floating-point unit (FPU), most versions of the 80486 CPU also included an integrated x87 FPU.

Expansion of the x86-32 microarchitectures continued with the introduction of the first Pentium brand processor in 1993. Known as the P5 microarchitecture, performance enhancements included a dual-instruction execution pipeline, 64-bit external data bus, and separate on-chip code and data caches. (A microarchitecture defines the organization of a processor's internal components, including its register files, execution

units, instruction pipelines, data buses, and memory caches. Microarchitectures are often used by multiple processor product lines as described in this section.) Later versions of the P5 microarchitecture incorporated a new computational resource called MMX technology, which supports single-instruction multiple-data (SIMD) operations on packed integers using 64-bit wide registers (1997).

The P6 microarchitecture, first used on the Pentium Pro (1995) and later on the Pentium II (1997), extended the x86-32 platform using a three-way superscalar design. This means that the processor is able (on average) to decode, dispatch, and execute three distinct instructions during each clock cycle. Other P6 augmentations included support for out-of-order instruction executions, improved branch-prediction algorithms, and speculative instruction executions. The Pentium III, also based on the P6 microarchitecture, was launched in 1999 and included a new SIMD technology called streaming SIMD extensions (SSE). SSE added eight 128-bit wide registers to the x86-32 platform and instructions that support packed single-precision (32-bit) floating-point arithmetic.

In 2000 Intel introduced a new microarchitecture called Netburst that included SSE2, which extended the floating-point capabilities of SSE to cover packed double-precision (64-bit) values. SSE2 also incorporated additional instructions that enabled the 128-bit SSE registers to be used for packed integer calculations and scalar floating-point operations. Processors based on the Netburst architecture included several variations of the Pentium 4. In 2004 the Netburst microarchitecture was upgraded to include SSE3 and hyper-threading technology. SSE3 adds packed integer and packed floating-point instructions to the x86 platform while hyper-threading technology parallelizes the processor's front-end instruction pipelines in order to improve performance. SSE3-capable processors include 90 nm (and smaller) versions of the Pentium 4 and the server-oriented Xeon product lines.

In 2006 Intel launched a new microarchitecture called Core. The Core microarchitecture included redesigns of many Netburst front-end pipelines and execution units in order to improve performance and reduce power consumption. It also incorporated a number of x86-SSE enhancements, including SSSE3 and SSE4.1. These extensions added new packed integer and packed floating-point instructions to the platform but no new registers or data types. Processors based on the Core microarchitecture include CPUs from the Core 2 Duo and Core 2 Quad series and the Xeon 3000/5000 series.

A microarchitecture called Nehalem followed Core in late 2008. The Nehalem microarchitecture re-introduced hyper-threading to the x86 platform, which had been excluded from the Core microarchitecture. It also incorporates SSE4.2. This final x86-SSE enhancement adds several application-specific accelerator instructions to the x86-SSE instruction set. SSE4.2 also includes four new instructions that facilitate text-string processing using the 128-bit wide x86-SSE registers. Processors based on the Nehalem microarchitecture include first generation Core i3, i5, and i7 CPUs. It also includes CPUs from the Xeon 3000, 5000, and 7000 series.

In 2011 Intel launched a new microarchitecture called Sandy Bridge. The Sandy Bridge microarchitecture introduced a new x86 SIMD technology called Advanced Vector Extensions (AVX). AVX adds packed floating-point operations (both single-precision and double-precision) using 256-bit wide registers. AVX also supports a new three-operand instruction syntax, which helps reduce the number of register-to-register data transfers

that a function must perform. Processors based on the Sandy Bridge microarchitecture include second- and third-generation Core i3, i5, and i7 CPUs along with Xeon series E3, E5, and E7 CPUs.

In 2013 Intel unveiled its Haswell microarchitecture. Haswell includes AVX2, which extends AVX to support packed-integer operations using its 256-bit wide registers. AVX2 also supports enhanced data transfer capabilities with its new set of broadcast, gather, and permute instructions. Another feature of the Haswell microarchitecture is its inclusion of fused-multiply-add (FMA) operations. FMA enables software to perform successive product-sum calculations using a single floating-point rounding operation. The Haswell microarchitecture also encompasses several new general-purpose register instructions. Processors based on the Haswell microarchitecture include fourth-generation Core i3, i5, and i7 CPUs and Xeon E3 (v3) series CPUs.

X86 platform extensions over the past several years have not been limited to SIMD enhancements. In 2003 AMD introduced its Opteron processor, which extended the x86's core architecture from 32 bits to 64 bits. Intel followed suit in 2004 by adding essentially the same 64-bit extensions to its processors, starting with certain versions of the Pentium 4. All Intel processors based on the Core, Nehalem, Sandy Bridge, and Haswell microarchitectures support the x86-64 execution environment.

Intel has also introduced several specialized microarchitectures that have been optimized for specific applications. The first of these is called Bonnell and was the basis for the original Atom processor in 2008. Atom processors built on this microarchitecture included support for SSSE3. In 2013 Intel introduced its Silvermont System on a Chip (SoC) microarchitecture, which is optimized for portable devices such as smartphones and tablet PCs. The Silvermont microarchitecture is also used in processors that are tailored for small servers, storage devices, network communications equipment, and embedded systems. Processors based on the Silvermont microarchitecture include SSE4.2 but lack x86-AVX. In 2013 Intel also introduced an ultra-low power SoC microarchitecture called Quark, which targets Internet-of-Things (IoT) and wearable computing devices. Processors based on the Quark microarchitecture only support the core x86-32 and x87 FPU instruction sets; they do not include x86-64 processing capabilities or any of the SIMD resources provided by MMX, x86-SSE, and x86-AVX.

Processors from AMD have also evolved over the past few years. In 2003 AMD introduced a series of processors based on its K8 microarchitecture. Original versions of the K8 included support for MMX, SSE, and SSE2, while later versions added SSE3. In 2007 the K10 microarchitecture was launched and included a SIMD enhancement called SSE4a. SSE4a contains several mask shift and streaming store instructions that are not available on processors from Intel. Following the K10, AMD introduced a new microarchitecture called Bulldozer in 2011. The Bulldozer microarchitecture includes SSSE3, SSE4.1, SSE4.2, SSE4a, and AVX. It also adds FMA4, which is a four-operand version of fused-multiply-add. Like SSE4a, FMA4 is not available on Intel from processors. A 2012 update to the Bulldozer microarchitecture called Piledriver includes support for both FMA4 and the three-operand version of FMA, which is called FMA3 by some CPU feature-detection utilities and third-party documentation sources.

Data Types

The x86-32 core architecture supports a wide variety of data types, which are primarily derived from a small set of fundamental data types. The data types that are most often manipulated by an application program include signed and unsigned integers, scalar single-precision and double-precision floating-point values, characters and text strings, and packed values. This section examines these types in greater detail along with a few miscellaneous data types supported by the x86.

Fundamental Data Types

A fundamental data type is an elementary unit of data that is manipulated by the processor during program execution. The x86 platform supports a comprehensive set of fundamental data types ranging in length from 8 bits (1 byte) to 256 bits (32 bytes). Table 1-1 shows these types along with typical uses.

Table 1-1. X86 Fundamental Data Types

Data Type	Length in Bits	Typical Use
Byte	8	Character, integers, Binary Coded Decimal (BCD) values
Word	16	Character, integers
Doubleword	32	Integers, single-precision floating-point
Quadword	64	Integers, double-precision floating-point, packed integers
Quintword	80	Double extended-precision floating-point, packed BCD
Double Quadword	128	Packed integers, packed floating-point
Quad Quadword	256	Packed integers, packed floating-point

Not surprisingly, most of the fundamental data types are sized using integer powers of two. The sole exception is the 80-bit quintword, which is used by the x87 FPU to support double extended-precision floating-point and packed BCD values.

The bits of a fundamental data type are numbered from right to left with zero and length - 1 used to identify the least and most significant bits, respectively. Fundamental data types larger than a single byte are stored in consecutive memory locations starting with the least-significant byte at the lowest memory address. This type of in-memory data arrangement is called little endian. Figure 1-1 illustrates the bit-numbering and byte-ordering schemes that are used by the fundamental data types.

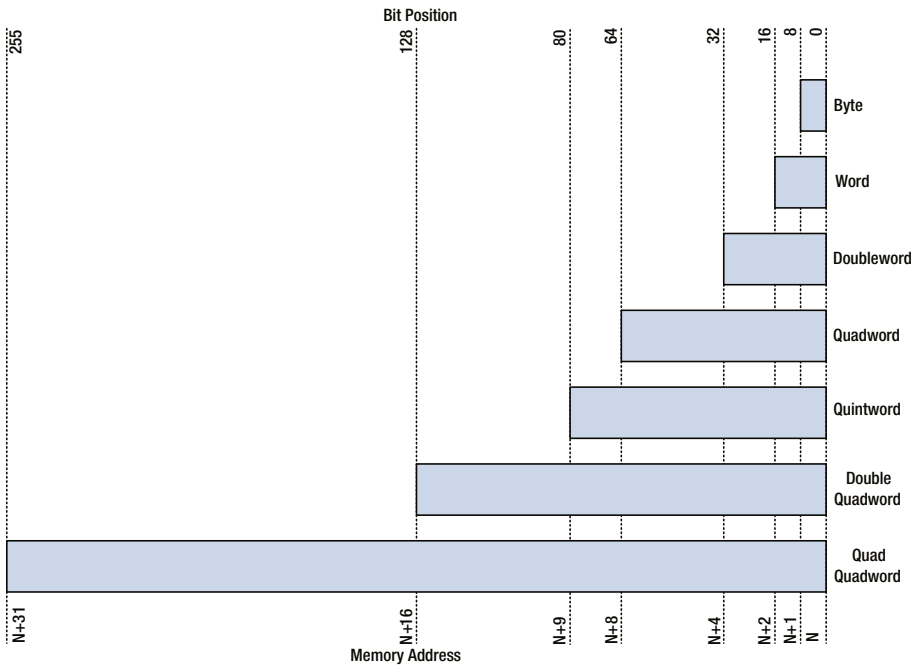

Figure 1-1. Bit-numbering and byte-ordering schemes used by the fundamental data types

A properly-aligned fundamental data type is one whose address is evenly divisible by its size in bytes. For example, a doubleword is properly aligned when it is stored at a memory location with an address that is evenly divisible by four. Similarly, quadwords are properly aligned at addresses evenly divisible by eight. Unless specifically enabled by the operating system, an x86 processor normally does not require proper alignment of multi-byte fundamental data types in memory. A notable exception to this rule are the x86-SSE and x86-AVX instruction sets, which usually require proper alignment of double quadword and quad quadword operands. Chapters 7 and 12 discuss the alignment requirements for x86-SSE and x86-AVX operands in greater detail. Regardless of any hardware-enforced memory alignment restrictions, it is strongly recommended that all multi-byte fundamental data types be properly aligned whenever possible in order to avoid potential performance penalties that can occur when the processor accesses misaligned data.

Numerical Data Types

A numerical data type is an elementary value such as an integer or floating-point number. All numerical data types recognized by the CPU are represented using one of the fundamental data types discussed in the previous section. Numerical data types can be divided into two subtypes: scalar and packed.

Scalar data types are used to perform calculations with discrete values. The x86 platform supports a set of scalar data types that resemble the basic data types available in C/C++. These are illustrated in Table 1-2. The x86-32 instruction set intrinsically supports operations on 8-, 16-, and 32-bit scalar integers, both signed and unsigned. A few instructions are also capable of manipulating 64-bit values. Comprehensive support for 64-bit values, however, requires x86-64 mode.

Table 1-2. *X86 Numerical Data Types*

Type	Size in Bits	Equivalent C/C++ Type
Signed integers	8	char
	16	short
	32	int, long
	64	long long
Unsigned integers	8	unsigned char
	16	unsigned short
	32	unsigned int, unsigned long
	64	unsigned long long
Floating-point	32	float
	64	double
	80	long double

The x87 FPU supports three different scalar floating-point encodings ranging in length from 32 to 80 bits. X86 assembly language functions can readily use any of the supported encodings. It should be noted, however, that C/C++ support for the 80-bit double extended-precision floating-point data encoding is not universal. Some compilers use the 64-bit encoding for both double and long double. Chapter 3 examines the x87 FPU and its supported data types in greater detail.

Packed Data Types

The x86 platform supports a variety of packed data types, which are employed to perform SIMD calculations using either integers or floating-point values. For example, a 64-bit wide packed data type can be used to hold eight 8-bit integers, four 16-bit integers, or two 32-bit integers. A 256-bit wide packed data type can hold a variety of data elements including 32 8-bit integers, 8 single-precision floating-point values, or 4 double-precision floating-point values. Table 1-3 lists the valid packed data type sizes along with the corresponding data element types and maximum possible number of data elements.

Table 1-3. X86 Packed Data Types

Packed Size (Bits)	Data Element Type	Number of Items
64	8-bit integers	8
	16-bit integers	4
	32-bit integers	2
128	8-bit integers	16
	16-bit integers	8
	32-bit integers	4
	64-bit integers	2
	Single-precision floating-point	4
	Double-precision floating-point	2
256	8-bit integers	32
	16-bit integers	16
	32-bit integers	8
	64-bit integers	4
	Single-precision floating-point	8
	Double-precision floating-point	4

As discussed earlier in this chapter, a number of SIMD enhancements have been added to the x86 platform over the years, starting with MMX technology and most recently with the addition of AVX2. One challenge of these periodic SIMD enhancements is that the packed data types described in Table 1-3 and their associated instruction sets are not universally supported by all processors. Developers need to keep this in mind when coding software modules using x86 assembly language. Fortunately, methods are available to determine at run-time the specific SIMD features that a processor supports.

Miscellaneous Data Types

The x86 platform also supports several miscellaneous data types including strings, bit fields, bit strings, and binary-coded decimal values.

An x86 string is contiguous block of bytes, words, or doublewords. X86 strings are used to support text-based data types and processing operations. For example, the C/C++ data types `char` and `wchar_t` are usually implemented using an x86 byte or word, respectively. X86 strings are also employed to perform processing operations on arrays, bitmaps, and similar contiguous-block data types. The x86 instruction set includes instructions that can perform compare, load, move, scan, and store operations using strings.

A bit field is a contiguous sequence of bits and is used as a mask value by some instructions. A bit field can start at any bit position of a byte and contain up to 32 bits.

A bit string is a contiguous sequence of bits containing up to $2^{32} - 1$ bits. The x86 instruction set includes instructions that can clear, set, scan, and test individual bits within a bit string.

Finally, a binary-coded-decimal (BCD) type is a representation of a decimal digit (0 – 9) using a 4-bit unsigned integer. The x86-32 instruction set includes instructions that perform basic arithmetic using packed (two BCD digits per byte) and unpacked (one BCD digit per byte) BCD values. The x87 FPU is also capable of loading and storing 80-bit packed BCD values to and from memory.

Internal Architecture

From the perspective of a running program, the internal architecture of an x86-32 processor can be logically partitioned into several distinct execution units. These include the core execution unit, the x87 FPU, and the SIMD execution units. By definition, an executing task must use the computational resources provided by the core execution unit. Using the x87 FPU or any of the SIMD execution units is optional. Figure 1-2 illustrates the internal architecture of an x86-32 processor.

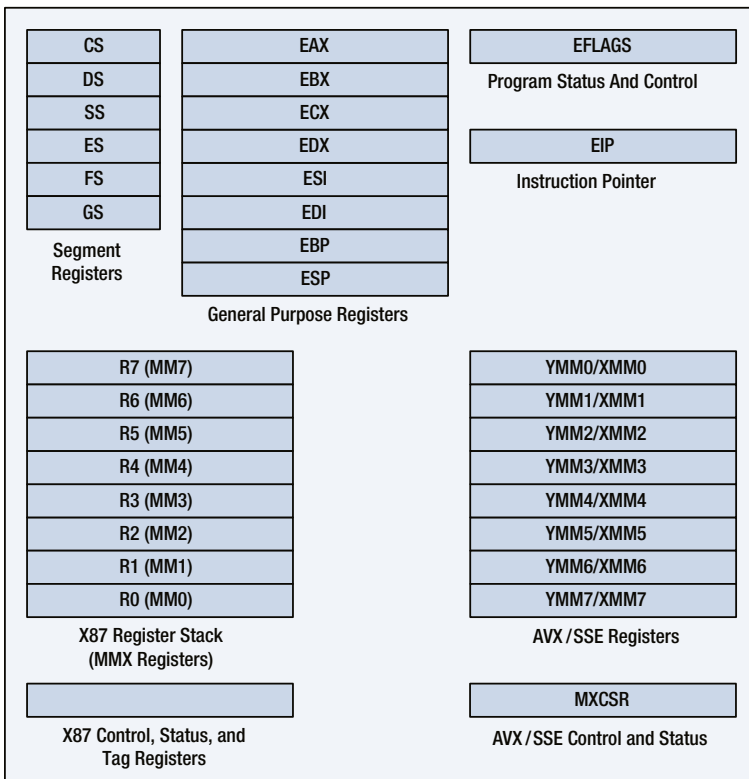

Figure 1-2. X86-32 internal architecture

The remainder of this section examines the x86-32 core execution unit in greater detail. It starts an exploration of the unit's register sets, including its segment registers, general-purpose registers, status flags register, and instruction pointer. This is followed by a discussion of instruction operands and memory addressing modes. The remaining execution units are examined later in this book. Chapter 3 explores the internal architecture of the x87 FPU, while Chapters 5, 7, and 12 delve into the architectural intricacies of MMX, x86-SSE, and x86-AVX, respectively.

Segment Registers

The x86-32 core execution unit uses segment registers to define a logical memory model for program execution and data storage. An x86 processor contains six segment registers that designate blocks of memory for code, data, and stack space. When operating in x86-32 protected mode, a segment register contains a segment selector, which is used as an index into a segment descriptor table that defines the segment's operational characteristics. A segment's operational characteristics include its size, type (code or data), and access rights (read or write). Segment register initialization and management is normally handled by the operating system. Most x86-32 application programs are written without any direct knowledge of how the segment registers are programmed.

General-Purpose Registers

The x86-32 core execution unit contains eight 32-bit general-purpose registers. These registers are primarily used to perform logical, arithmetic, and address calculations. They also can be employed for temporary storage and as pointers to data items that are stored in memory. Figure 1-3 shows the complete set of general-purpose registers along with the names that are used to specify a register as an instruction operand. Besides supporting 32-bit operands, the general-purpose registers also can perform calculations using 8-bit or 16-bit operands. For example, a function can use registers AL, BL, CL, and DL to perform 8-bit calculations in the low-order bytes of registers EAX, EBX, ECX, and EDX, respectively. Similarly, the registers AX, BX, CX, and DX can be used to carry out 16-bit calculations in the low-order words.

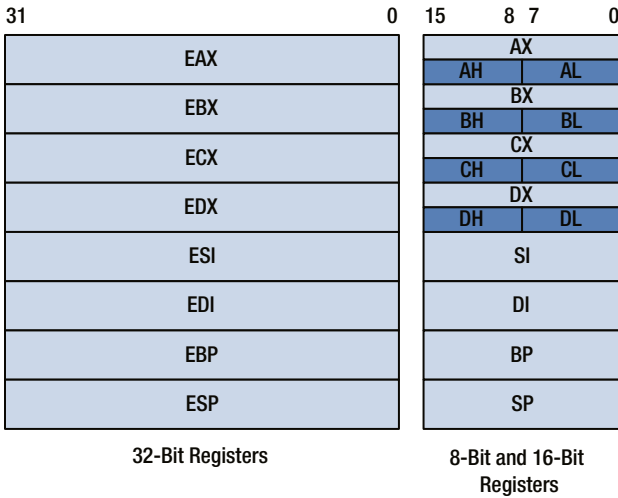

Figure 1-3. X86-32 general-purpose registers

Despite their designation as general-purpose registers, the x86-32 instruction set imposes some noteworthy restrictions on how they can be used. Many instructions either require or implicitly use specific registers as operands. For example, some variations of the `imul` (Signed Multiply) and `idiv` (Signed Divide) instructions use the EDX register to hold the high-order doubleword of a product or dividend. The string instructions require that the addresses of the source and destination operands be placed in the ESI and EDI registers, respectively. String instructions that include a repeat prefix must use ECX as the count register, while variable bit shift and rotate instructions must load the bit count value into the CL register.

The processor uses the ESP register to support stack-related operations such as function calls and returns. The stack itself is simply a contiguous block of memory that is assigned to a process or thread by the operating system. Application programs can also use the stack to pass function arguments and store temporary data. Register ESP always points to the stack's top-most item. While it is possible to use the ESP register as a general-purpose register, such use is impractical and strongly discouraged. Register EBP is typically used as a base pointer to access data items that are stored on the stack (ESP can also be used as a base pointer to access data items on the stack). When not employed as a base pointer, EBP can be used as a general-purpose register.

The mandatory or implicit use of specific registers by some instructions is a legacy design pattern that dates back to the 8086, ostensibly to improve code density. What this means from a modern programming perspective is that certain register usage conventions tend to be observed when writing x86-32 assembly code. Table 1-4 lists the general-purpose registers and their conventional uses.

Table 1-4. *Conventional Uses for General-Purpose Registers*

Register	Conventional Use
EAX	Accumulator
EBX	Memory pointer, base register
ECX	Loop control, counter
EDX	Integer multiplication, integer division
ESI	String instruction source pointer, index register
EDI	String instruction destination pointer, index register
ESP	Stack pointer
EBP	Stack frame base pointer

A couple of items to note: The usage conventions shown in Table 1-4 are common practices, but are not compulsory. The x86-32 instruction set does not, for example, prevent an executing task from using the ECX register as a memory pointer despite its conventional use as a counter. Also, x86 assemblers do not enforce these usage conventions. Given the limited number general-purpose registers available in x86-32 mode, it is frequently necessary to use a general-purpose register in a non-conventional manner. Finally, it should be noted that the usage conventions outlined in Table 1-4 are not the same as a calling convention defined by a high-level language such as C++. Calling conventions must be observed and are discussed further in Chapter 2.

EFLAGS Register

The EFLAGS register contains a series of status bits that the processor uses to indicate the results of logical and arithmetic operations. It also contains a collection of system control bits that are primarily used by operating systems. Table 1-5 shows the organization of the bits in the EFLAGS register.

Table 1-5. *EFLAGS Register*

Bit	Name	Symbol	Use
0	Carry Flag	CF	Status
1	Reserved		1
2	Parity Flag	PF	Status
3	Reserved		0
4	Auxiliary Carry Flag	AF	Status
5	Reserved		0
6	Zero Flag	ZF	Status
7	Sign Flag	SF	Status
8	Trap Flag	TF	System
9	Interrupt Enable Flag	IF	System
10	Direction Flag	DF	Control
11	Overflow Flag	OF	Status
12	I/O Privilege Level Bit 0	IOPL	System
13	I/O Privilege Level Bit 1	IOPL	System
14	Nested Task	NT	System
15	Reserved		0
16	Resume Flag	RF	System
17	Virtual 8086 Mode	VM	System
18	Alignment Check	AC	System
19	Virtual Interrupt Flag	VIF	System
20	Virtual Interrupt Pending	VIP	System
21	ID Flag	ID	System
22 - 31	Reserved		0

For application programs, the most important bits in the EFLAGS register are the following status flags: auxiliary carry flag (AF), carry flag (CF), overflow flag (OF), parity flag (PF), sign flag (SF), and zero flag (ZF). The auxiliary carry flag denotes a carry or borrow condition during binary-coded decimal addition or subtraction. The carry flag is set by the processor to signify an overflow condition when performing unsigned integer arithmetic. It is also used by some register rotate and shift instructions. The overflow flag signals that the result of a signed integer operation is too small or too large. The parity flag

indicates whether the least-significant byte of a result contains an even number of 1 bits. The sign and zero flags are set by logical and arithmetic instructions to signify a negative, zero, or positive result.

The EFLAGS register also contains a control bit called the direction flag (DF). An application program can set or reset the direction flag, which defines the auto increment direction (0 = low-to-high addresses, 1 = high-to-low addresses) of the EDI and ESI registers during execution of the string instructions. The remaining bits in the EFLAGS register are used exclusively by the operating system to manage interrupts, restrict I/O operations, and support program debugging. They should never be modified by an application program. Reserved bits should also never be modified and no assumptions should ever be made regarding the state of any reserved bit.

Instruction Pointer

The instruction pointer register (EIP) contains the offset of the next instruction to be executed. The EIP register is implicitly manipulated by control-transfer instructions. For example, the `call` (Call Procedure) instruction pushes the contents of the EIP register onto the stack and transfers program control to the address designated by the specified operand. The `ret` (Return from Procedure) instruction transfers program control by popping the top-most item off the stack into the EIP register.

The `jmp` (Jump) and `jcc` (Jump if Condition is Met) instructions also transfer program control by modifying the contents of the EIP register. Unlike the `call` and `ret` instructions, all x86-32 jump instructions are executed independent of the stack. It should also be noted that it is not possible for an executing task to directly access the EIP register.

Instruction Operands

Most x86-32 instructions use operands, which designate the specific values that an instruction will act upon. Nearly all instructions require one or more source operands along with a single destination operand. Most instructions also require the programmer to explicitly specify the source and destination operands. There are, however, a number of instructions where the operands are either implicitly specified or forced by the instruction.

There are three basic types of operands: immediate, register, and memory. An immediate operand is a constant value that is encoded as part of the instruction. These are typically used to specify constant arithmetic, logical, or offset values. Only source operands can be used as immediate operands. Register operands are contained in a general-purpose register. A memory operand specifies a location in memory, which can contain any of the data types described earlier in this chapter. An instruction can specify either the source or destination operand as a memory operand, but not both. Table 1-6 contains several examples of instructions that employ the various operand types.

Table 1-6. *Examples of Instruction Operands*

Type	Example	Equivalent C/C++ Statement
Immediate	<code>mov eax,42</code>	<code>eax = 42</code>
	<code>imul ebx,11h</code>	<code>ebx *= 0x11</code>
	<code>xor dl,55h</code>	<code>dl ^= 0x55</code>
	<code>add esi,8</code>	<code>esi += 8</code>
Register	<code>mov eax,ebx</code>	<code>eax = ebx</code>
	<code>inc ecx</code>	<code>ecx += 1</code>
	<code>add ebx,esi</code>	<code>ebx += esi</code>
	<code>mul ebx</code>	<code>edx:eax = eax * ebx</code>
Memory	<code>mov eax,[ebx]</code>	<code>eax = *ebx</code>
	<code>add eax,[val1]</code>	<code>eax += *val1</code>
	<code>or ecx,[ebx+esi]</code>	<code>ecx = *(ebx + esi)</code>
	<code>sub word ptr [edi],12</code>	<code>*(short*)edi -= 12</code>

The `mul` (Unsigned Multiply) instruction that is shown in Table 1-6 is an example of implicit operand use. In this instance, implicit register EAX and explicit register EBX are used as the source operands; the implicit register pair EDX:EAX is used as the destination operand. The multiplicative product's high-order and low-order doublewords are stored in EDX and EAX, respectively.

The word `ptr` text that is used in the final memory example is an assembler operator that acts like a C++ cast operator. In this instance, the value 12 is subtracted from a 16-bit value whose memory location is specified by the contents of the EDI register. Without the operator, the assembly language statement is ambiguous since the assembler can't ascertain the size of the operand pointed to by the EDI register. In this case, the value could also be an 8-bit or 32-bit sized operand. The programming chapters of this book contain additional information regarding assembler operator and directive use.

Memory Addressing Modes

The x86-32 instruction set supports using up to four separate components to specify a memory operand. The four components include a fixed displacement value, a base register, an index register, and a scale factor. Subsequent to each instruction fetch that specifies a memory operand, the processor calculates an effective address in order to determine the final memory address of the operand. An effective address is calculated as follows:

$$\text{Effective Address} = \text{BaseReg} + \text{IndexReg} * \text{ScaleFactor} + \text{Disp}$$

The base register (BaseReg) can be any general-purpose register; the index register (IndexReg) can be any general-purpose register except ESP; displacement (Disp) values are constant offsets that are encoded within the instruction; valid scale factors (ScaleFactor) include 1, 2, 4, and 8. The size of the final effective address (EffectiveAddress) is always 32 bits. It is not necessary for an instruction to explicitly specify all of the components that the processor uses to calculate an effective address. The x86-32 instruction set supports eight different memory-operand addressing forms, as listed in Table 1-7.

Table 1-7. Memory Operand Addressing Forms

Addressing Form	Example
Disp	<code>mov eax, [MyVal]</code>
BaseReg	<code>mov eax, [ebx]</code>
BaseReg + Disp	<code>mov eax, [ebx+12]</code>
Disp + IndexReg * SF	<code>mov eax, [MyArray+esi*4]</code>
BaseReg + IndexReg	<code>mov eax, [ebx+esi]</code>
BaseReg + IndexReg + Disp	<code>mov eax, [ebx+esi+12]</code>
BaseReg + IndexReg * SF	<code>mov eax, [ebx+esi*4]</code>
BaseReg + IndexReg * SF + Disp	<code>mov eax, [ebx+esi*4+20]</code>

Table 1-7 also shows examples of how to use the various memory-operand addressing forms with the `mov` (Move) instruction. In these examples, the doubleword value at the memory location specified by the effective address is copied into the EAX register.

Most of the addressing forms shown in Table 1-7 can be used to reference common data types and structures. For example, the simple displacement form is often used to access a global or static variable. The base register form is analogous to a C++ pointer and is used to reference a single value. Individual fields within a structure can be specified using a based register and a displacement. The index register forms are useful for accessing an element within an array. The scale factors facilitate easy access to the elements of arrays that contain fundamental data types such as integers, single-precision floating-point values, and double-precision floating point values. Finally, the use of a base register in combination with an index register is useful for accessing the elements of a two-dimensional array.

Instruction Set Overview

The following section presents a brief overview of the x86-32 instruction set. The purpose of this section is to provide you with a general understanding of the x86-32 instruction set. The instruction descriptions are deliberately succinct since complete details of each instruction including execution particulars, valid operands, affected flags, and exceptions are readily available in Intel's and AMD's reference manuals. Appendix C contains a list of these manuals. The programming examples of Chapter 2 also contain additional comments regarding the use of these instructions.

Many x86-32 instructions update one or more of the status flags in the EFLAGS register. As discussed earlier in this chapter, the status flags provide additional information about the results of an operation. The `jcc`, `cmovcc` (Conditional Move), and `setcc` (Set Byte on Condition) instructions use what are called condition codes to test the status flags either individually or in multiple-flag combinations. Table 1-8 lists the condition codes, mnemonic suffixes, and the corresponding flags used by these instructions. Note that in the column labeled “Test Condition” and in the impending instruction descriptions, the C++ operators `==`, `!=`, `&&`, and `||` are used to signify equality, inequality, logical AND, and logical OR, respectively.

Table 1-8. Condition Codes, Mnemonic Suffixes, and Test Conditions

Condition Code	Mnemonic Suffix	Test Condition
Above	A	CF == 0 && ZF == 0
Neither below or equal	NBE	
Above or equal	AE	CF == 0
Not below	NB	
Below	B	CF == 1
Neither above nor equal	NAE	
Below or equal	BE	CF == 1 ZF == 1
Not above	NA	
Equal	E	ZF == 1
Zero	Z	
Not equal	NE	ZF == 0
Not zero	NZ	
Greater	G	ZF == 0 && SF == 0F
Neither less nor equal	NLE	
Greater or equal	GE	SF == 0F
Not less	NL	
Less	L	SF != 0F
Neither greater nor equal	NGE	
Less or equal	LE	ZF == 1 SF != 0F
Not greater	NG	
Sign	S	SF == 1
Not sign	NS	SF == 0

(continued)

Table 1-8. (continued)

Condition Code	Mnemonic Suffix	Test Condition
Carry	C	CF == 1
Not carry	NC	CF == 0
Overflow	O	OF == 1
Not overflow	NO	OF == 0
Parity	P	PF == 1
Parity even	PE	
Not parity	NP	PF == 0
Parity odd	PO	

Many of the condition codes shown in Table 1-8 include alternate mnemonics, which are used to improve program readability. When using one of the aforementioned conditional instructions, condition-codes containing the words “above” and “below” are employed for unsigned-integer operands, while the words “greater” and “less” are used for signed-integer operands. If the condition code definitions in Table 1-7 seem a little confusing or abstract, don’t worry. You’ll see a plethora of condition code examples throughout this book.

In order to assist you in understanding the x86-32 instruction set, the instructions have been grouped into the following functional categories:

- Data transfer
- Data comparison
- Data conversion
- Binary arithmetic
- Logical
- Rotate and shift
- Byte set and bit strings
- String
- Flags
- Control transfer
- Miscellaneous

In the instruction descriptions that follow, GPR is used as an abbreviation for general-purpose register.

Data Transfer

The data-transfer group contains instructions that copy or exchange data between two general-purpose registers or between a general-purpose register and memory. Both conditional and unconditional data moves are supported. The group also includes instructions that push data onto or pop data from the stack. Table 1-9 summarizes the data-transfer instructions.

Table 1-9. *Data-Transfer Instructions*

Mnemonic	Description
mov	Copies data from/to a GPR or memory location to/from a GPR or memory location. The instruction also can be used to copy an immediate value to a GPR or memory location.
cmovcc	Conditionally copies data from a memory location or GPR to a GPR. The cc in the mnemonic denotes a condition code from Table 1-8.
push	Pushes a GPR, memory location, or immediate value onto the stack. This instruction subtracts four from ESP and copies the specified operand to the memory location pointed to by ESP.
pop	Pops the top-most item from the stack. This instruction copies the contents of the memory location pointed to by ESP to the specified GPR or memory location; it then adds four to ESP.
pushad	Pushes the contents of all eight GPRs onto the stack.
popad	Pops the stack to restore the contents of all GPRs. The stack value for ESP is ignored.
xchg	Exchanges data between two GPRs or a GPR and a memory location. The processor uses a locked bus cycle if the register-memory form of the instruction is used.
xadd	Exchanges data between two GPRs or a GPR and a memory location. The sum of the two operands is then saved to the destination operand.
movsx	Sign-extends the contents of a GPR or memory location and copies the result value to a GPR.
movzx	Zero-extends the contents of a GPR or memory location and copies the result to a GPR.

Binary Arithmetic

The binary arithmetic group contains instructions that perform addition, subtraction, multiplication, and division using signed and unsigned integers. It also contains instructions that are used to perform adjustments on packed and unpacked BCD values. Table 1-10 describes the binary arithmetic instructions.

Table 1-10. *Binary Arithmetic Instructions*

Mnemonic	Description
<code>add</code>	Adds the source operand and destination operand. This instruction can be used for both signed and unsigned integers.
<code>adc</code>	Adds the source operand, destination operand, and the state of <code>EFLAGS.CY</code> . This instruction can be used for both signed and unsigned integers.
<code>sub</code>	Subtracts the source operand from the destination operand. This instruction can be used for both signed and unsigned integers.
<code>sbb</code>	Subtracts the sum of the source operand and <code>EFLAGS.CY</code> from the destination operand. This instruction can be used for both signed and unsigned integers.
<code>imul</code>	Performs a signed multiply between two operands. This instruction supports multiple forms, including a single source operand (with <code>AL</code> , <code>AX</code> , or <code>EAX</code> as an implicit operand), an explicit source and destination operand, and a three-operand variant (immediate source, memory/register source, and GPR destination).
<code>mul</code>	Performs an unsigned multiply between the source operand and the <code>AL</code> , <code>AX</code> , or <code>EAX</code> register. The results are saved in the <code>AX</code> , <code>DX:AX</code> , or <code>EDX:EAX</code> registers.
<code>idiv</code>	Performs a signed division using <code>AX</code> , <code>DX:AX</code> , or <code>EDX:EAX</code> as the dividend and the source operand as the divisor. The resultant quotient and remainder are saved in register pair <code>AL:AH</code> , <code>AX:DX</code> , or <code>EAX:EDX</code> .
<code>div</code>	Performs an unsigned division using <code>AX</code> , <code>DX:AX</code> , or <code>EDX:EAX</code> as the dividend and the source operand as the divisor. The resultant quotient and remainder are saved in register pair <code>AL:AH</code> , <code>AX:DX</code> , or <code>EAX:EDX</code> .
<code>inc</code>	Adds one to the specified operand. This instruction does not affect the value of <code>EFLAGS.CY</code> .
<code>dec</code>	Subtracts one from the specified operand. This instruction does not affect the value <code>EFLAGS.CY</code> .
<code>neg</code>	Computes the two's complement value of the specified operand.
<code>daa</code>	Adjusts the contents of the <code>AL</code> register following an <code>add</code> instruction using packed BCD values in order to produce a correct BCD result.
<code>das</code>	Adjusts the contents of the <code>AL</code> register following a <code>sub</code> instruction using packed BCD values in order to produce a correct BCD result.
<code>aaa</code>	Adjusts the contents of the <code>AL</code> register following an <code>add</code> instruction using unpacked BCD values in order to produce a correct BCD result.
<code>aas</code>	Adjusts the contents of the <code>AL</code> register following a <code>sub</code> instruction using unpacked BCD values in order to produce a correct BCD result.
<code>aam</code>	Adjusts the contents of the <code>AX</code> register following a <code>mul</code> instruction using unpacked BCD values in order to produce a correct BCD result.
<code>aad</code>	Adjusts the contents of the <code>AX</code> register to prepare for an unpacked BCD division. This instruction is applied before a <code>div</code> instruction that uses unpacked BCD values.

Data Comparison

The data-comparison group contains instructions that compare two operands and set various status flags, which indicate the results of the comparison. Table 1-11 lists the data-comparison instructions.

Table 1-11. *Data-Comparison Instructions*

Mnemonic	Description
<code>cmp</code>	Compares two operands by subtracting the source operand from the destination and then sets the status flags. The results of the subtraction are discarded. The <code>cmp</code> instruction is typically used before a <code>jcc</code> , <code>cmovcc</code> , or <code>setcc</code> instruction.
<code>cmpxchg</code>	Compares the contents of register AL, AX, or EAX with the destination operand and performs an exchange based on the results.
<code>cmpxchg8b</code>	Compares EDX:EAX with an 8-byte memory operand and performs an exchange based on the results.

Data Conversion

The data-conversion group contains instructions that are used to sign-extend an integer value in the AL, AX, or EAX register. A sign-extension operation replicates a source operand's sign bit to the high-order bits of the destination operand. For example, sign-extending the 8-bit value 0xe9 (-23) to 16-bits yields 0xffe9. This group also contains instructions that support little-endian to big-endian conversions. Table 1-12 details the data-conversion instructions.

Table 1-12. *Data-Conversion Instructions*

Mnemonic	Description
<code>cbw</code>	Sign-extends register AL and saves the results in register AX.
<code>cwde</code>	Sign-extends register AX and saves the results in register EAX.
<code>cwd</code>	Sign-extends register AX and saves the results in register pair DX:AX.
<code>cdq</code>	Sign-extends register EAX and saves the results in register pair EDX:EAX.
<code>bswap</code>	Reverses the bytes of a value in a 32-bit GPR, which converts the original value from little-endian ordering to big-endian ordering or vice versa.
<code>movbe</code>	Loads the source operand into a temporary register, reverses the bytes, and saves the result to the destination operand. This instruction converts the source operand from little-endian to big-endian format or vice versa. One of the operands must be a memory location; the other operand must be a GPR.
<code>xlatb</code>	Converts the value contained in the AL register to another value using a lookup table pointed to by the EBX register.

Logical

The logical group contains instructions that perform bitwise logical operations on the specified operands. The processor updates status flags EFLAGS.PF, EFLAGS.SF, and EFLAGS.ZF to reflect the results of these instructions except where noted. Table 1-13 summarizes the instructions in the logical group.

Table 1-13. *Logical Instructions*

Mnemonic	Description
and	Calculates the bitwise AND of the source and destination operands.
or	Calculates the bitwise inclusive OR of the source and destination operands.
xor	Calculates the bitwise exclusive OR of the source and destination operands.
not	Calculates the one's complement of the specified operand. This instruction does not affect the status flags.
test	Calculates the bitwise AND of the source and destination operand and discards the results. This instruction is used to non-destructively set the status flags.

Rotate and Shift

The rotate and shift group contains instructions that perform operand rotations and shifts. Several forms of these instructions are available that support either single-bit or multiple-bit operations. Multiple-bit rotations and shifts use the CL register to specify the bit count. Rotate operations can be performed with or without the carry flag. Table 1-14 lists the rotate and shift instructions.

Table 1-14. *Rotate and Shift Instructions*

Mnemonic	Description
rcl	Rotates the specified operand to the left. EFLAGS.CY flag is included as part of the rotation.
rcr	Rotates the specified operand to the right. EFLAGS.CY flag is included as part of the rotation.
rol	Rotates the specified operand to the left.
ror	Rotates the specified operand to the right.
sal/shl	Performs an arithmetic left shift of the specified operand.
sar	Performs an arithmetic right shift of the specified operand.
shr	Performs a logical right shift of the specified operand.
shld	Performs a double-precision logical left shift using two operands.
shrd	Performs a double-precision logical right shift using two operands.

Byte Set and Bit String

The byte set and bit string instruction group contains instructions that conditionally set a byte value. This group also contains the instructions that process bit strings. Table 1-15 describes the byte set and bit string instructions.

Table 1-15. *Byte Set and Bit String Instructions*

Mnemonic	Description
setcc	Sets the destination byte operand to 1 if the condition code specified by cc is true; otherwise the destination byte operand is set to 0.
bt	Copies the designated test bit to EFLAGS.CY.
bts	Copies the designated test bit to EFLAGS.CY. The test bit is then set to 1.
btr	Copies the designated test bit to EFLAGS.CY. The test bit is then set to 0.
btc	Copies the designated test bit to EFLAGS.CY. The test bit is then set to 0.
bsf	Scans the source operand and saves to the destination operand the index of the least-significant bit that is set to 1. If the value of the source operand is zero, EFLAGS.ZF is set to 1; otherwise, EFLAGS.ZF is set to 0.
bsr	Scans the source operand and saves to the destination operand the index of the most-significant bit that is set to 1. If the value of the source operand is zero, EFLAGS.ZF is set to 1; otherwise, EFLAGS.ZF is set to 0.

String

The string-instruction group contains instructions that perform compares, loads, moves, scans, and stores of text strings or blocks of memory. All of the string instructions use register ESI as the source pointer and register EDI as the destination pointer. The string instructions also increment or decrement these registers depending on the value of the direction flag (EFLAGS.DF). Repeated execution of a string instruction using register ECX as a counter is possible with a rep, repe/ repz, or repne / repnz prefix. Table 1-16 lists the string instructions.

Table 1-16. *String Instructions*

Mnemonic	Description
cmpsb cmpsw cmpsd	Compares the values at the memory locations pointed to by registers ESI and EDI; sets the status flags to indicate the results.
lodsb lodsw lodsd	Loads the value at the memory location pointed to by register ESI into the AL, AX, or EAX register.
movsb movsw movsd	Copies the value of the memory location specified by register ESI to the memory location specified by register EDI.
scasb scasw scasd	Compares the value of the memory location specified by register EDI with the value contained in register AL, AX, or EAX; sets the status flags based on the comparison results.
stosb stosw stosd	Stores the contents of register AL, AX, or EAX to the memory location specified by register EDI.
rep	Repeats the specified string instruction while the condition ECX != 0 is true.
repe repz	Repeats the specified string instruction while the condition ECX != 0 && ZF == 1 is true.
repne repnz	Repeats the specified string instruction while the condition ECX != 0 && ZF == 0 is true.

Flag Manipulation

The flag-manipulation group contains instructions that can be used to manipulate some of the status flags in the EFLAGS register. Table 1-17 lists these instructions.

Table 1-17. *Flag-Manipulation Instructions*

Mnemonic	Description
cld	Sets EFLAGS.CY to 0.
stc	Sets EFLAGS.CY to 1.
cmc	Toggles the state of EFLAGS.CY.
std	Sets EFLAGS.DF to 1.
cld	Sets EFLAGS.DF to 0.

(continued)

Table 1-17. (continued)

Mnemonic	Description
lahf	Loads register AH with the values of the status flags. The bits of register AH (most significant to least significant) are loaded as follows: EFLAGS.SF, EFLAGS.ZF, 0, EFLAGS.AF, 0, EFLAGS.PF, 1, EFLAGS.CF.
sahf	Stores register AH to the status flags. The bits of register AH (most significant to least significant) are stored to the status flags as follows: EFLAGS.SF, EFLAGS.ZF, 0, EFLAGS.AF, 0, EFLAGS.PF, 1, EFLAGS.CF (a zero or one indicates the actual value used instead of the corresponding bit in register AH).
pushfd	Pushes the EFLAGS register onto the stack.
popfd	Pops the top most value from the stack and copies it to the EFLAGS register. Note that the reserved bits in the EFLAGS register are not affected by this instruction.

Control Transfer

The control-transfer group contains instructions that perform jumps, function calls and returns, and looping constructs. Table 1-18 summarizes the control-transfer instructions.

Table 1-18. Control-Transfer Instructions

Mnemonic	Description
jmp	Performs an unconditional jump to the memory location specified by the operand.
jcc	Performs a conditional jump to the memory location specified by the operand if the identified condition is true. The cc denotes a condition-code mnemonic from Table 1-8.
call	Pushes the contents of register EIP onto the stack and then performs an unconditional jump to the memory location that is specified by the operand.
ret	Pops the target address off the stack and then performs an unconditional jump to that address.
enter	Creates a stack frame that enables to a function's parameters and local data by initializing the EBP and ESP registers.
leave	Removes the stack frame that was created using an enter instruction by restoring the caller's EBP and ESP registers.

(continued)

Table 1-18. (continued)

Mnemonic	Description
jecxz	Performs a jump to the specified memory location if the condition <code>ECX == 0</code> is true.
loop	Subtracts one from register ECX and jumps to the specified memory location if the condition <code>ECX == 0</code> is true.
loope loopz	Subtracts one from register ECX and jumps to the specified memory location if the condition <code>ECX != 0 && ZF == 1</code> is true.
loopne loopnz	Subtracts one from register ECX and jumps to the specified memory location if the condition <code>ECX != 0 && ZF == 0</code> is true.

Miscellaneous

The miscellaneous group contains instructions that do not fit into one of the preceding categories. These instructions are described in Table 1-19.

Table 1-19. *Miscellaneous Instructions*

Mnemonic	Description
bound	Performs a validation check of an array index. If an out-of-bounds condition is detected, the processor generates an interrupt.
lea	Computes the effective address of the source operand and saves it to the destination operand, which must be a general-purpose register.
nop	Advances the instruction pointer (EIP) to the next instruction. No other registers or flags are modified.
cpuid	Obtains processor identification and feature information. This instruction can be used to ascertain at run-time which SIMD extensions are available. It also can be used to determine specific hardware features that the processor supports.

Summary

This chapter examined the core architecture of the x86-32 platform, including its data types and internal architecture. It also reviewed those portions of the x86-32 instruction set that are most useful in application programs. If this is your first encounter with the internal architecture of x86 platform or assembly language programming, some of the presented material may seem a little esoteric. As mentioned in the Introduction, all of the chapters in this book are either instructional or structured for hands-on learning. The next chapter focuses on the practical aspects of x86 assembly language programming using sample code and concise examples that expand on many of the concepts discussed here.

CHAPTER 2



X86-32 Core Programming

The previous chapter focused on the fundamentals of the x86-32 platform, including its data types, execution environment, and instruction set. This chapter concentrates on the basics of x86-32 assembly language programming. More specifically, you'll examine how to code x86 assembly language functions that can be called from a C++ program. You'll also learn about the semantics and syntax of x86 assembly language source code file. The sample programs and accompanying remarks of this chapter are intended to complement the instructive material presented in Chapter 1.

This chapter's content is organized as follows. The first section describes how to code a simple assembly language function. You'll explore the essentials of passing arguments and return values between functions written in C++ and x86 assembly language. You'll also consider some of the issues related to x86-32 instruction set use and learn a little bit about the Visual Studio development tools.

The next section discusses the fundamentals of x86-32 assembly language programming. It presents additional details regarding passing arguments and using return values between functions, including function prologs and epilogs. This section also reviews several universal x86 assembly language programming topics, including memory addressing modes, variable use, and conditional instructions. Following the section on assembly language fundamentals is a section that discusses array use. Virtually all applications employ arrays to some degree and the content of this section illustrates assembly language programming techniques using one-dimensional and two-dimensional arrays.

Many application programs also use structures to create and manage user-defined data types. Structure use is illustrated in the next section and includes a discussion of several issues that developers need to be aware of when using structures between C++ and assembly-language functions. The final section of this chapter demonstrates using the x86's string instructions. These instructions are commonly used to perform operations with text strings, but they also can be used to process the elements of an array.

It should be noted that the primary purpose of the sample code presented in this chapter is to illustrate x86-32 instruction set use and basic assembly language programming techniques. All of the assembly language code is straightforward, but not necessarily optimal since understanding optimized assembly language code can be challenging, especially for beginners. The sample code that's discussed in later chapters places more emphasis on efficient coding techniques. Chapters 21 and 22 also review a number of strategies that can be used to create efficient assembly language code.

Getting Started

This section examines a couple of simple programs that illustrate how to pass data between a C++ function and an x86-32 assembly language function. You'll also learn how to use a few common x86-32 assembly language instructions and some basic assembler directives. As mentioned in the Introduction, all of the sample code discussed in this book was created using Microsoft's Visual C++ and Macro Assembler (MASM), which are included with Visual Studio. Before you take a look at the first sample program, you need to learn a few requisites about these development tools.

Visual Studio uses entities called *solutions* and *projects* to help simplify application development. A solution is a collection of one or more projects that are used to build an application. Projects are container objects that help organize an application's files, including source code, resources, icons, bitmaps, HTML, and XML. A Visual Studio project is usually created for each buildable component (e.g. executable file, dynamic-linked library, static library, etc.) of an application. You can open and load any of the sample programs into the Visual Studio development environment by double-clicking on its solution (.sln) file. You'll explore Visual Studio use a bit more later in this section. Appendix A also contains a brief tutorial on how to create a Visual Studio solution and project that includes both C++ and x86 assembly language files.

First Assembly Language Function

The first x86-32 assembly language program that you'll examine is called CalcSum. This sample program demonstrates some basic assembly language concepts, including argument passing, stack use, and return values. It also illustrates how to use several common assembler directives.

Before diving into the specifics of sample program CalcSum, let's review what happens when a C++ function calls another function. Like many programming languages, C++ uses a stack-oriented architecture to support argument passing and local variable storage. In Listing 2-1, the function CalcSumTest calculates and returns the sum of three integer values. Prior to the calling of this function from `_tmain`, the values of `a`, `b`, and `c` are pushed onto the stack from right to left. Upon entry into CalcSumTest, a stack frame pointer is initialized that facilitates access to the three integer arguments that were pushed onto the stack in `_tmain`. The function also allocates any local stack space it needs. Next, CalcSumTest calculates the sum, copies this value into a pre-designated return value register, releases any previously-allocated local stack space, and returns to `_tmain`. It should be noted that while the preceding discussion is conceptually accurate, a modern C++ compiler is likely to eliminate some if not all of the stack-related operations using either local or whole-program optimization.

Listing 2-1. CalcSumTest.cpp

```
#include "stdafx.h"

int CalcSumTest(int a, int b, int c)
{
    return a + b + c;
}
```

```
int _tmain(int argc, _TCHAR* argv[])
{
    int a = 17, b = 11, c = 14;
    int sum = CalcSumTest(a, b, c);

    printf(" a:  %d\n", a);
    printf(" b:  %d\n", b);
    printf(" c:  %d\n", c);
    printf(" sum: %d\n", sum);
    return 0;
}
```

The same function-calling procedure outlined in the previous paragraph is also used to invoke an assembly language function from C++. Listings 2-2 and 2-3 show the C++ and x86 assembly language code for the sample program CalcSum. In this example, the assembly language function is named CalcSum_. Since CalcSum_ is your first x86-32 assembly language function, it makes sense to methodically examine Listings 2-2 and 2-3.

Listing 2-2. CalcSum.cpp

```
#include "stdafx.h"

extern "C" int CalcSum_(int a, int b, int c);

int _tmain(int argc, _TCHAR* argv[])
{
    int a = 17, b = 11, c = 14;
    int sum = CalcSum_(a, b, c);

    printf(" a:  %d\n", a);
    printf(" b:  %d\n", b);
    printf(" c:  %d\n", c);
    printf(" sum: %d\n", sum);
    return 0;
}
```

Listing 2-3. CalcSum_.asm

```
.model flat,c
.code

; extern "C" int CalcSum_(int a, int b, int c)
;
; Description: This function demonstrates passing arguments between
;             a C++ function and an assembly language function.
;
; Returns:    a + b + c
```

```

CalcSum_ proc
; Initialize a stack frame pointer
    push ebp
    mov ebp,esp

; Load the argument values
    mov eax,[ebp+8]           ; eax = 'a'
    mov ecx,[ebp+12]        ; ecx = 'b'
    mov edx,[ebp+16]        ; edx = 'c'

; Calculate the sum
    add eax,ecx              ; eax = 'a' + 'b'
    add eax,edx              ; eax = 'a' + 'b' + 'c'

; Restore the caller's stack frame pointer
    pop ebp
    ret

CalcSum_ endp
end

```

■ **Note** In the sample code, all assembly language file, function, and public variable names include a trailing underscore for easier recognition.

The file `CalcSum.cpp` looks straightforward but includes a few lines that warrant some explanatory comments. The `#include "stdafx.h"` statement specifies a project-specific header file that contains references to frequently used system items. Visual Studio automatically generates this file whenever a new C++ console application project is created. The line `extern "C" int CalcSum_(int a, int b, int c)` is a C++ declaration statement that defines the parameters and return value for the assembly language function `CalcSum_`. It also instructs the compiler to use the C-style naming convention for the function `CalcSum_`, instead of a C++ decorated name (a C++ decorated name includes extra characters that help support overloading). The remaining lines in `CalcSum.cpp` perform standard console output using the `printf` function.

The first few lines of `CalcSum_.asm` are MASM directives. A MASM directive is a statement that instructs the assembler how to perform certain actions. The `.model flat,c` directive tells the assembler to produce code for a flat memory model and to use C-style names for public symbols. The `.code` statement defines the starting point of a memory block that contains executable code. You'll learn how to use other directives throughout this chapter. The next few lines are comments; any character that appears on a line after a semicolon is ignored by the assembler. The statement `CalcSum_ proc` indicates the start of the function (or procedure). Toward the end of the source file, the statement `CalcSum_ endp` marks the end of the function. It should be noted that the `proc` and `endp` statements are not executable instructions but assembler directives that

denote the beginning and end of a function. The final end statement is another assembler directive that signifies the end of statements for the file; the assembler ignores any text that appears after the end directive.

The first x86-32 assembly-language instruction of `CalcSum_` is `push ebp` (Push Doubleword onto the Stack). This instruction saves the contents of the caller's EBP register on the stack. The next instruction, `mov ebp, esp` (Move), copies the contents of ESP to EBP, which initializes EBP as a stack frame pointer for `CalcSum_` and enables access to the function's arguments. Figure 2-1 illustrates the contents of the stack following execution of the `mov ebp, esp` instruction. The saving of the caller's EBP register and initialization of the stack frame pointer form part of a code block known as the function prolog. Function prologs are discussed in greater detail later in this chapter.

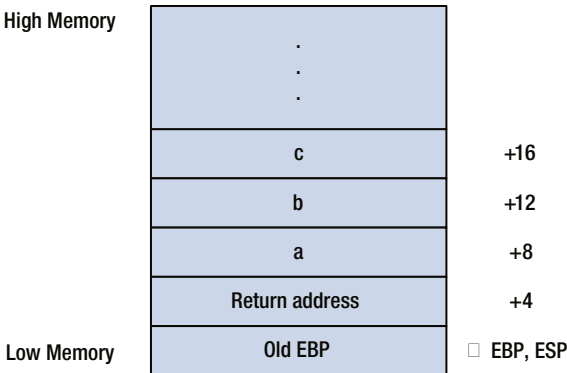

Figure 2-1. Contents of the stack after initialization of the stack frame pointer. Offsets of data on the stack are relative to registers EBP and ESP

Following initialization of the stack frame pointer, the argument values arguments `a`, `b`, and `c` are loaded into registers EAX, ECX, and EDX, respectively, using a series of `mov` instructions. The source operand of each `mov` instruction uses the `BaseReg+Disp` form of memory addressing to reference each value on the stack (see Chapter 1 for more information on memory addressing modes). After loading the argument values into registers, calculation of the required sum can commence. The `add eax, ecx` (Add) instruction sums registers EAX and ECX, which contain the argument values `a` and `b`, and saves the result to register EAX. The next instruction `add eax, edx` adds `c` to the previously computed sum and saves the result in EAX.

An x86-32 assembly language function must use the EAX register to return a 32-bit integer value to its calling function. In the current program, no additional instructions are required to achieve this since EAX already contains the correct value. The `pop ebp` (Pop a Value from the Stack) instruction restores the caller's EBP register and is considered part of the function's epilog code. Function epilogs are discussed in greater detail later in this chapter. The final `ret` (Return from Procedure) instruction transfers program control back to the calling function `_tmain`. Output 2-1 shows the results of running the sample program `CalcSum`.

Output 2-1. Sample Program Calcsum

```

a: 17
b: 11
c: 14
sum: 42

```

You can view the source code files and run the sample program using Visual Studio by performing the following steps:

1. Using the Windows File Explorer, double-click on the following Visual Studio solution file:
Chapter02\CalcSum\CalcSum.sln.
2. If necessary, select VIEW ► Solution Explorer to open the Solution Explorer Window.
3. In the Solution Explorer Window tree control, expand the nodes labeled CalcSum and Source Files.
4. Double-click on CalcSum.cpp and CalcSum.asm to open the files in the editor.
5. To run the program, select DEBUG ► Start Without Debugging.

You'll learn a few more details about Visual Studio use throughout this chapter.

Integer Multiplication and Division

The next sample program that you'll examine is called `IntegerMulDiv`. This program demonstrates how to perform signed-integer multiplication and division using the `imul` (Signed Multiply) and `idiv` (Signed Divide) instructions, respectively. It also illustrates how to pass data between a C++ function and an assembly language function using pointers. You can open the Visual Studio solution file using Windows Explorer by doubling-click on the `Chapter02\IntegerMulDiv\IntegerMulDiv.sln` file.

Listing 2-4 shows the C++ source code for `IntegerMulDiv.cpp`. Near the top of this file is a declaration statement for the assembly language function that will calculate the required results. The function `IntegerMulDiv_` defines five parameters: two integer data values and three integer pointers for the results. This function also returns an integer value that indicates a division-by-zero error condition. The remaining lines in the file `IntegerMulDiv.cpp` contain code that exercise the assembly language function `IntegerMulDiv_` using several test cases.

Listing 2-4. IntegerMulDiv.cpp

```

#include "stdafx.h"

extern "C" int IntegerMulDiv_(int a, int b, int* prod, int* quo, int* rem);

int _tmain(int argc, _TCHAR* argv[])
{
    int a = 21, b = 9;
    int prod = 0, quo = 0, rem = 0;
    int rc;

    rc = IntegerMulDiv_(a, b, &prod, &quo, &rem);
    printf(" Input1 - a:  %4d b:  %4d\n", a, b);
    printf("Output1 - rc:  %4d prod: %4d\n", rc, prod);
    printf("          quo: %4d rem:  %4d\n\n", quo, rem);

    a = -29;
    prod = quo = rem = 0;
    rc = IntegerMulDiv_(a, b, &prod, &quo, &rem);
    printf(" Input2 - a:  %4d b:  %4d\n", a, b);
    printf("Output2 - rc:  %4d prod: %4d\n", rc, prod);
    printf("          quo: %4d rem:  %4d\n\n", quo, rem);

    b = 0;
    prod = quo = rem = 0;
    rc = IntegerMulDiv_(a, b, &prod, &quo, &rem);
    printf(" Input3 - a:  %4d b:  %4d\n", a, b);
    printf("Output3 - rc:  %4d prod: %4d\n", rc, prod);
    printf("          quo: %4d rem:  %4d\n\n", quo, rem);
    return 0;
}

```

Listing 2-5 contains the assembly language function `IntegerMulDiv_`. The first few lines of this function are similar to the first few lines of sample program you studied in the previous section; they contain assembler directives that define the memory model and the start of a code block. The function prolog contains the necessary instructions to save the caller's EBP register and initialize a stack frame pointer. It also includes a `push ebx` instruction, which saves the caller's EBX register on the stack. According to the Visual C++ calling convention that is defined for 32-bit programs, a called function must preserve the values of the following registers: EBX, ESI, EDI, and EBP. These registers are called non-volatile registers. The volatile registers EAX, ECX, and EDX need not be preserved across function calls. You'll learn more about the Visual C++ calling convention and its requirements throughout the remainder of this chapter.

Listing 2-5. IntegerMulDiv_.asm

```

.model flat,c
.code

; extern "C" int IntegerMulDiv_(int a, int b, int* prod, int* quo, int*
↳ rem);
;
; Description: This function demonstrates use of the imul and idiv
;              instructions. It also illustrates pointer usage.
;
; Returns:     0 Error (divisor is zero)
;              1 Success (divisor is zero)
;
; Computes:    *prod = a * b;
;              *quo = a / b
;              *rem = a % b

IntegerMulDiv_ proc

; Function prolog
    push ebp
    mov ebp,esp
    push ebx

; Make sure the divisor is not zero
    xor eax,eax                ;set error return code
    mov ecx,[ebp+8]           ;ecx = 'a'
    mov edx,[ebp+12]          ;edx = 'b'
    or  edx,edx
    jz  InvalidDivisor        ;jump if 'b' is zero

; Calculate product and save result
    imul edx,ecx              ;edx = 'a' * 'b'
    mov  ebx,[ebp+16]          ;ebx = 'prod'
    mov [ebx],edx             ;save product

; Calculate quotient and remainder, save results
    mov  eax,ecx              ;eax = 'a'
    cdq                          ;edx:eax contains dividend
    idiv dword ptr [ebp+12]    ;eax = quo, edx = rem

    mov  ebx,[ebp+20]          ;ebx = 'quo'
    mov [ebx],eax             ;save quotient
    mov  ebx,[ebp+24]          ;ebx = 'rem'
    mov [ebx],edx             ;save remainder
    mov  eax,1                 ;set success return code

```

```

; Function epilog
InvalidDivisor:
    pop ebx
    pop ebp
    ret
IntegerMulDiv_ endp
    end

```

Figure 2-2 shows the contents of the stack subsequent to the `push ebx` instruction. Following the function prolog, the argument values `a` and `b` are loaded into registers `ECX` and `EDX`, respectively. An `or edx,edx` (Logical Inclusive OR) instruction follows. This instruction performs a bitwise inclusive OR of `EDX` with itself, which updates the status flags in the `EFLAGS` register while preserving the original value in register `EDX`. The argument `b` is being tested in order to avoid a division-by-zero condition. The `jz InvalidDivisor` (Jump if Zero) instruction that follows is a conditional jump instruction that gets performed only if `EFLAGS.ZF == 1` is true. The destination operand of this conditional jump instruction is a label that specifies the target of the jump (i.e. the next instruction to be executed) if the zero flag is set. In the current sample program, the target label `InvalidDivisor:` is located toward the end of the listing just before the first epilog instruction.

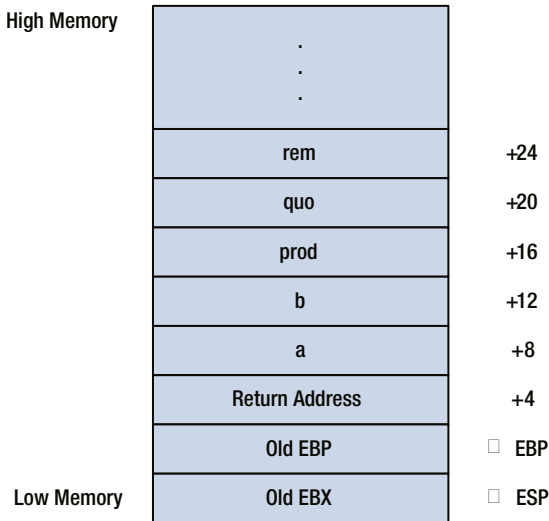

Figure 2-2. Stack contents after execution of `push ebx`. Offsets shown are relative to register `EBP`

If the value of `b` is not zero, program execution continues with the `imul edx,ecx` instruction. This instruction multiplies the contents of `EDX` and `ECX` using signed-integer multiplication, truncates the product to 32-bits, and saves this value in register `EDX` (the one-operand form of `imul` with 32-bit operands saves the complete quadword product in register pair `EDX:EAX`). The next instruction, `mov ebx,[ebp+16]`, loads the pointer `prod` into register `EBX`. This is followed by a `mov [ebx],edx` instruction that saves the previously-calculated multiplicative product to the required memory location.

The next block of x86-32 instructions in `IntegerMulDiv_` calculates a / b and $a \% b$ using signed-integer division. On an x86 processor, signed-integer division using 32-bit wide operands must be performed using a 64-bit wide dividend that is loaded in register pair EDX:EAX. The `cdq` (Convert Doubleword to Quadword) instruction sign-extends the contents of EAX, which contains argument `a` due to the preceding `mov eax, ecx` instruction, into register pair EDX:EAX. The next instruction, `idiv dword ptr [ebp+12]`, performs the signed integer division. Note that the `idiv` instruction specifies only a single source operand: the 32-bit (or doubleword) divisor. The contents of register pair EDX:EAX is always used as the dividend. It should be noted that the `idiv` instruction can also be used to perform 8-bit and 16-bit signed integer division, which explains the `dword ptr` operator that's used in the current example. Following execution of the `idiv` instruction, registers EAX and EDX contain the quotient and remainder, respectively. These values are then saved to the memory locations specified by the pointers `quo` and `rem`.

The final block of code in function `IntegerMulDiv_` contains the epilog. Before execution of the `ret` instruction, the caller's EBX and EBP registers must be restored using `pop` instructions. If an assembly language function fails to properly restore a non-volatile registers that it altered, a program crash is likely to occur. This same disastrous outcome is virtually guaranteed to happen if ESP points to an unremoved data item on the stack or contains an invalid value. The results of the sample program `IntegerMulDiv` are shown in Output 2-2.

Output 2-2. Sample Program `IntegerMulDiv`

```

Input1 - a:      21  b:      9
Output1 - rc:    1  prod:  189
          quo:    2  rem:   3

Input2 - a:     -29  b:      9
Output2 - rc:    1  prod: -261
          quo:   -3  rem:   -2

Input3 - a:     -29  b:      0
Output3 - rc:    0  prod:   0
          quo:    0  rem:   0

```

X86-32 Programming Fundamentals

The sample code of the previous section introduced x86-32 assembly language programming. In this section, you'll continue exploring by focusing on the fundamentals of x86-32 assembly language programming. You'll begin by taking a closer look at the calling convention that x86-32 assembly language functions must observe in order to be callable from C++. This is followed by a sample program that illustrates how to employ commonly-used memory addressing modes. Integer addition using various-sized operands is the primary emphasis of the next sample program while the final sample program surveys condition codes and conditional instructions. The title of this section includes the word "fundamentals" and should provide a clue as to its importance. All of the presented material encompasses essential topics that aspiring x86 assembly language programmers need to fully understand.

Calling Convention

When writing functions using C++, programmers frequently declare one or more local variables that hold temporary values or intermediate results. For example, in Listing 2-6 you see that the function `LocalVars` contains three local variables: `val1`, `val2`, and `val3`. If the C++ compiler determines that memory is needed on the stack to hold these variables or other temporary values, it is usually allocated and released in the function's prolog and epilog, respectively. Assembly-language functions can use this same technique to allocate space on the stack for local variables or other transient uses.

Listing 2-6. `LocalVars.cpp`

```
double LocalVars(int a, int b)
{
    int val1 = a * a;
    int val2 = b * b;
    double val3 = sqrt(val1 + val2);

    return val3;
}
```

The next sample program that you'll study is called `CallingConvention` and its purpose is twofold. First, it illustrates some additional aspects of the C++ calling convention, including allocation of space on the stack for local variable storage. Second, the sample program demonstrates proper use of a few more commonly-used x86-32 assembly language instructions. The C++ and assembly language listings for `CallingConvention.cpp` and `CallingConvention.asm` are shown in Listings 2-7 and 2-8. The Visual Studio solution file is named `Chapter02\CallingConvention\CallingConvention.sln`.

Listing 2-7. `CallingConvention.cpp`

```
#include "stdafx.h"

extern "C" void CalculateSums_(int a, int b, int c, int* s1, int* s2, int*
↳ s3);

int _tmain(int argc, _TCHAR* argv[])
{
    int a = 3, b = 5, c = 8;
    int s1a, s2a, s3a;

    CalculateSums_(a, b, c, &s1a, &s2a, &s3a);

    // Compute the sums again so we can verify the results
    // of CalculateSums_().
```

```

int s1b = a + b + c;
int s2b = a * a + b * b + c * c;
int s3b = a * a * a + b * b * b + c * c * c;

printf("Input:  a:  %4d b:  %4d c:  %4d\n", a, b, c);
printf("Output: s1a: %4d s2a: %4d s3a: %4d\n", s1a, s2a, s3a);
printf("        s1b: %4d s2b: %4d s3b: %4d\n", s1b, s2b, s3b);

return 0;
}

```

Listing 2-8. CallingConvention_.asm

```

.model flat,c
.code

; extern "C" void CalculateSums_(int a, int b, int c, int* s1, int* s2, int*
↪s3);
;
; Description: This function demonstrates a complete assembly
;              language prolog and epilog.
;
; Returns: None.
;
; Computes:    *s1 = a + b + c
;              *s2 = a * a + b * b + c * c
;              *s3 = a * a * a + b * b * b + c * c * c

CalculateSums_ proc

; Function prolog
    push ebp
    mov  ebp,esp
    sub  esp,12                ;Allocate local storage space
    push ebx
    push esi
    push edi

; Load arguments
    mov  eax,[ebp+8]           ;eax = 'a'
    mov  ebx,[ebp+12]          ;ebx = 'b'
    mov  ecx,[ebp+16]          ;ecx = 'c'
    mov  edx,[ebp+20]          ;edx = 's1'
    mov  esi,[ebp+24]          ;esi = 's2'
    mov  edi,[ebp+28]          ;edi = 's3'

```

```

; Compute 's1'
    mov [ebp-12],eax
    add [ebp-12],ebx
    add [ebp-12],ecx                                ;final 's1' result

; Compute 's2'
    imul eax,eax
    imul ebx,ebx
    imul ecx,ecx
    mov [ebp-8],eax
    add [ebp-8],ebx
    add [ebp-8],ecx                                ;final 's2' result

; Compute 's3'
    imul eax,[ebp+8]
    imul ebx,[ebp+12]
    imul ecx,[ebp+16]
    mov [ebp-4],eax
    add [ebp-4],ebx
    add [ebp-4],ecx                                ;final 's3' result

; Save 's1', 's2', and 's3'
    mov eax,[ebp-12]
    mov [edx],eax                                  ;save 's1'
    mov eax,[ebp-8]
    mov [esi],eax                                  ;save 's2'
    mov eax,[ebp-4]
    mov [edi],eax                                  ;save 's3'

; Function epilog
    pop edi
    pop esi
    pop ebx
    mov esp,ebp                                    ;Release local storage space
    pop ebp
    ret
CalculateSums_ endp
end

```

You can see in Listing 2-7 that `_tmain` calls a function named `CalculateSums_`. This function calculates three sum values using the provided integer arguments. The assembly language definition of `CalculateSums_` that's shown in Listing 2-8 begins with the now familiar stack frame pointer initialization along with the preservation of all non-volatile registers on the stack. Before the non-volatile registers are saved, a `sub esp,12` (Subtract) instruction is executed. This instruction subtracts 12 from the contents of ESP register, which effectively allocates 12 bytes of local (and private) storage space on the stack that can be used by the function. The reason a `sub` instruction is used instead of an `add`

instruction is because the x86's stack grows downward toward lower-memory addresses. The allocation of local storage space on the stack reveals another purpose of the prolog's `mov ebp, esp` instruction. When using the EBP register to access values on the stack, function arguments are always referenced using positive displacement values, while local variables are referenced using negative displacement values, as illustrated in Figure 2-3.

High Memory	s3	+28
	s2	+24
	s1	+20
	c	+16
	b	+12
	a	+8
	Return Address	+4
	Old EBP	←EBP
	Temp s3	-4
	Temp s2	-8
	Temp s1	-12
	Old EBX	
	Old ESI	
Low Memory	Old EDI	←ESP

Figure 2-3. Organization of a stack with local storage space

Following the prolog code, the function arguments `a`, `b`, and `c` are loaded into registers EAX, EBX, and ECX, respectively. The calculation of `s1` illustrates the use of an `add` instruction with a memory destination operand instead of a register. I should note that in this particular case, the use of a memory destination operand is inefficient; `s1` easily could be computed using register operands. The reason for employing memory destination operands here is to elucidate the use of local variables on the stack.

The values of `s2` and `s3` are then calculated using the two-operand form of `imul`. Note that the `imul` instructions employed to calculate `s3` use the original values on the stack as source operands since the contents of EAX, EBX, and ECX no longer contain the original values of `a`, `b`, and `c`. Subsequent to the calculation of the required results, the values `s1`, `s2`, `s3`, are copied from their temporary locations on the stack to the caller's memory locations using the provided pointers.

`CalculateSums_` concludes with an epilog that restores the non-volatile registers EBX, ESI, and EDI using `pop` instructions. It also includes a `mov esp,ebp` instruction, which essentially releases the previously allocated local storage space and restores the ESP register to the correct value prior to execution of the `ret` instruction. Execution of the sample program `CallingConvention` yields text that's shown in Output 2-3.

Output 2-3. Sample Program `CallingConvention`

```
Input:  a:      3  b:      5  c:      8
Output: s1a:   16 s2a:   98 s3a:  664
        s1b:   16 s2b:   98 s3b:  664
```

The prolog and epilog of `CalculateSums_` are typical examples of the calling convention that must be observed when invoking an assembly-language function from a Visual C++ function. Later in this chapter, you will explore a couple of additional calling convention requirements related to 64-bit values and C++ structures. Chapter 4 also discusses the calling convention requirements for floating-point values. Appendix B contains a complete summary of the Visual C++ calling convention for x86-32 programs.

■ **Note** The assembly language calling convention described in this chapter may be different for other high-level languages and operating systems. If you're reading this book to learn x86 assembly language programming and plan on using it in a different execution environment, you should consult the appropriate documentation for specific information regarding the target platform's calling convention.

Finally, when coding an assembly language function prolog or epilog, it is usually only necessary to include those instructions that are specifically needed by the function. For example, if a function does not alter the contents of register EBX, it is not necessary for the prolog to save and the epilog to restore its value. Similarly, a function that defines zero parameters is not required to initialize a stack frame pointer. The one caveat of skipping a prolog or epilog action is the situation where an assembly language function calls another function that does not preserve the non-volatile registers. In this case, the calling function should ensure that the non-volatile registers are properly saved and restored.

Memory Addressing Modes

You learned in Chapter 1 that the x86 instruction set supports a variety of addressing modes that can be used to reference an operand in memory. In this section, you'll examine an assembly-language function that illustrates how to use some of these modes. You'll also learn how to define an assembly language lookup table and a global variable that can be accessed from a C++ function. The name of the sample program for this section is called `MemoryAddressing`. Listings 2-9 and 2-10 show the contents of the source files `MemoryAddressing.cpp` and `MemoryAddressing.asm`, respectively. The Visual Studio solution file for this sample program is named `Chapter02\MemoryAddressing\MemoryAddressing.sln`.

Listing 2-9. MemoryAddressing.cpp

```

#include "stdafx.h"

extern "C" int NumFibVals;
extern "C" int MemoryAddressing_(int i, int* v1, int* v2, int* v3, int* v4);

int _tmain(int argc, _TCHAR* argv[])
{
    for (int i = -1; i < NumFibVals_ + 1; i++)
    {
        int v1 = -1, v2 = -1, v3 = -1, v4 = -1;
        int rc = MemoryAddressing_(i, &v1, &v2, &v3, &v4);

        printf("i: %2d rc: %2d - ", i, rc);
        printf("v1: %5d v2: %5d v3: %5d v4: %5d\n", v1, v2, v3, v4);
    }

    return 0;
}

```

Listing 2-10. MemoryAddressing.asm

```

.model flat,c

; Simple lookup table (.const section data is read only)

        .const
FibVals    dword 0, 1, 1, 2, 3, 5, 8, 13
           dword 21, 34, 55, 89, 144, 233, 377, 610

NumFibVals_ dword ($ - FibVals) / sizeof dword
           public NumFibVals_

; extern "C" int MemoryAddressing_(int i, int* v1, int* v2, int* v3, int*
↳ v4);
;
; Description: This function demonstrates various addressing
;              modes that can be used to access operands in
;              memory.
;
; Returns:     0 = error (invalid table index)
;              1 = success

        .code
MemoryAddressing_ proc
           push ebp
           mov ebp,esp

```

```

    push ebx
    push esi
    push edi

; Make sure 'i' is valid
    xor eax,eax
    mov ecx,[ebp+8]           ;ecx = i
    cmp ecx,0
    jl InvalidIndex         ;jump if i < 0
    cmp ecx,[NumFibVals_]
    jge InvalidIndex       ;jump if i >=NumFibVals_

; Example #1 - base register
    mov ebx,offset FibVals   ;ebx = FibVals
    mov esi,[ebp+8]         ;esi = i
    shl esi,2               ;esi = i * 4
    add ebx,esi             ;ebx = FibVals + i * 4
    mov eax,[ebx]          ;load table value
    mov edi,[ebp+12]
    mov [edi],eax          ;Save to 'v1'

; Example #2 - base register + displacement
; esi is used as the base register
    mov esi,[ebp+8]         ;esi = i
    shl esi,2               ;esi = i * 4
    mov eax,[esi+FibVals]  ;load table value
    mov edi,[ebp+16]
    mov [edi],eax          ;Save to 'v2'

; Example #3 - base register + index register
    mov ebx,offset FibVals   ;ebx = FibVals
    mov esi,[ebp+8]         ;esi = i
    shl esi,2               ;esi = i * 4
    mov eax,[ebx+esi]      ;load table value
    mov edi,[ebp+20]
    mov [edi],eax          ;Save to 'v3'

; Example #4 - base register + index register * scale factor
    mov ebx,offset FibVals   ;ebx = FibVals
    mov esi,[ebp+8]         ;esi = i
    mov eax,[ebx+esi*4]    ;load table value
    mov edi,[ebp+24]
    mov [edi],eax          ;Save to 'v4'
    mov eax,1               ;Set return code

```



```

InvalidIndex:
    pop edi
    pop esi
    pop ebx
    pop ebp
    ret
MemoryAddressing_ endp
end

```

Let's start by examining the assembly language function named `MemoryOperands_`. In this function, the parameter named `i` is employed as an index into an array (or lookup table) of constant integers, while the four pointer variables are used to save values read from the lookup table using different addressing modes. Near the top of Listing 2-10 is a `.const` directive, which defines a memory block that contains read-only data. Immediately following the `.const` directive, a lookup table named `FibVals` is defined. This table contains 16 doubleword integer values; the text `dword` is an assembler directive that is used to allocate storage space and optionally initialize a doubleword value (the text `dd` can also be used as a synonym for `dword`).

The line `NumFibVals_ dword ($ - FibVals) / sizeof dword` allocates storage space for a single doubleword value and initializes it with the number of doubleword elements in the lookup table `FibVals`. The `$` character is an assembler symbol that equals the current value of the location counter (or offset from the beginning of the current memory block). Subtracting the offset of `FibVals` from `$` yields the size of the table in bytes; dividing this result by the size in bytes of a doubleword value generates the correct number of elements. The statements in the `.const` section replicate a commonly-used technique in C++ to define and initialize a variable with the number of elements in an array:

```

int Values[] = {10, 20, 30, 40, 50};
int NumValues = sizeof(Values) / sizeof(int);

```

The final line of the `.const` section declares `NumFibVals_` as a public symbol in order to enable its use by the function `_tmain`.

Let's now look at the assembly language code for `MemoryAddressing_`. Immediately following the function's prolog, the argument `i` is checked for validity since it will be used as an index into the lookup table `FibVals`. The `cmp ecx, 0` (Compare Two Operands) instruction compares the contents of ECX, which contains `i`, to the immediate value 0. The processor carries out this comparison by subtracting the source operand from the destination operand; it then sets the status flags based on the result of the subtraction (the result is not saved to the destination operand). If the condition `ecx < 0` is true, program control will be transferred to the location specified by the `j1` (Jump if Less) instruction. A similar sequence of instructions is used to determine if the value of `i` is too large. In this case, a `cmp ecx, [NumFibVals_]` instruction compares ECX against the number of elements in the lookup table. If `ecx >= [NumFibVals]` is true, a jump is performed to the target location specified by the `jge` (Jump if Greater or Equal) instruction.

The remaining instructions of the function `MemoryAddressing_` illustrate accessing items in the lookup table using various memory addressing modes. The first example uses a single base register to read an item from the table. In order to use a single base register, the function must manually calculate the address of the *i*-th table element, which

is achieved by adding the offset (or starting address) of `FibVals` and the value `i * 4`. The `mov ebx, offset FibVals` instruction loads EBX with the correct table offset value. The value of `i` is then loaded into ESI, followed by a `shl esi, 2` (Shift Logical Left) instruction. This computes the offset of the *i*-th item relative to the start of the lookup table. An `add ebx, esi` instruction calculates the final address. Once this is complete, the specified table value is read using a `mov eax, [ebx]` instruction and saved to the memory location specified by the argument `v1`.

The second memory-addressing example uses the `BaseReg+Disp` form to read a table item. Like the previous example, the offset of the *i*-th table element relative to the start of the table is calculated using a `shl esi, 2` instruction. The correct table entry is then loaded into EAX using a `mov eax, [esi+FibVals]` instruction. In this example, the processor computes the final effective address by adding the contents of ESI (the base register) and the displacement (or offset) of `FibVals`.

In the third memory-addressing example, the table value is read using `BaseReg+IndexReg` memory addressing. This example is similar to the first example except that the processor computes the final effective address during execution of the `mov eax, [ebx+esi]` instruction. The fourth and final example demonstrates the use of `BaseReg+IndexReg*ScaleFactor` addressing. In this example, the offset of `FibVals` and the value `i` are loaded into registers EBX and ESI, respectively. The correct table value is loaded into EAX using a `mov eax, [ebx+esi*4]` instruction.

The file `MemoryAddressing.cpp` (Listing 2-10) contains a simple looping construct that exercises the function `MemoryOperands_` including cases with an invalid index. Note that the `for` loop uses the variable `NumFibVals_`, which was defined as a public symbol in the assembly language file `MemoryOperands_.asm`. The output for the sample program `MemoryAddressing` is shown in Output 2-4.

Output 2-4. Sample Program `MemoryAddressing`

```
i: -1 rc: 0 - v1:    -1 v2:    -1 v3:    -1 v4:    -1
i:  0 rc: 1 - v1:     0 v2:     0 v3:     0 v4:     0
i:  1 rc: 1 - v1:     1 v2:     1 v3:     1 v4:     1
i:  2 rc: 1 - v1:     1 v2:     1 v3:     1 v4:     1
i:  3 rc: 1 - v1:     2 v2:     2 v3:     2 v4:     2
i:  4 rc: 1 - v1:     3 v2:     3 v3:     3 v4:     3
i:  5 rc: 1 - v1:     5 v2:     5 v3:     5 v4:     5
i:  6 rc: 1 - v1:     8 v2:     8 v3:     8 v4:     8
i:  7 rc: 1 - v1:    13 v2:    13 v3:    13 v4:    13
i:  8 rc: 1 - v1:    21 v2:    21 v3:    21 v4:    21
i:  9 rc: 1 - v1:    34 v2:    34 v3:    34 v4:    34
i: 10 rc: 1 - v1:    55 v2:    55 v3:    55 v4:    55
i: 11 rc: 1 - v1:    89 v2:    89 v3:    89 v4:    89
i: 12 rc: 1 - v1:   144 v2:   144 v3:   144 v4:   144
i: 13 rc: 1 - v1:   233 v2:   233 v3:   233 v4:   233
i: 14 rc: 1 - v1:   377 v2:   377 v3:   377 v4:   377
i: 15 rc: 1 - v1:   610 v2:   610 v3:   610 v4:   610
i: 16 rc: 0 - v1:    -1 v2:    -1 v3:    -1 v4:    -1
```

Given the multiple addressing modes that are available on an x86 processor, you might wonder which mode should be used most often. The answer to this question depends on a number of factors including register availability, the number of times an instruction (or sequence of instructions) is expected to execute, instruction ordering, and memory space vs. execution time tradeoffs. Hardware features such as the processor's underlying microarchitecture and memory cache sizes also need to be considered.

When coding an x86 assembly language function, one suggested guideline is to use simple (a single register or displacement) rather than complex (multiple registers) instruction forms to reference an operand in memory. The drawback of this approach is that the simpler forms generally require the programmer to code longer instruction sequences and may consume more code space. The use of a simple form also may be imprudent if extra instructions are needed to preserve non-volatile registers on the stack. In Chapters 21 and 22, you'll learn about some of the issues that can affect the efficiency of assembly language code in greater detail.

Integer Addition

Visual C++ supports the standard C++ fundamental types, including `char`, `short`, `int`, and `long long`. These parallel the x86 fundamental types `byte`, `word`, `doubleword`, and `quadword`, respectively. This section examines a program that performs integer addition using various-sized integers. You'll also learn how to use global variables defined in a C++ file from an x86 assembly language function and a few more commonly used x86 instructions. The Visual Studio solution file for this section is named `Chapter02\IntegerAddition\IntegerAddition.sln` and the source code files are shown in Listings 2-11 and 2-12.

Listing 2-11. IntegerAddition.cpp

```
#include "stdafx.h"

extern "C" char G1Char = 10;
extern "C" short G1Short = 20;
extern "C" int G1Int = 30;
extern "C" long long G1LongLong = 0x00000000FFFFFFFFFE;

extern "C" void IntegerAddition_(char a, short b, int c, long long d);

int _tmain(int argc, _TCHAR* argv[])
{
    printf("Before G1Char:    %d\n", G1Char);
    printf("      G1Short:    %d\n", G1Short);
    printf("      G1Int:      %d\n", G1Int);
    printf("      G1LongLong: %lld\n", G1LongLong);
    printf("\n");

    IntegerAddition_(3, 5, -37, 11);
```

```

printf("After  GlChar:    %d\n", GlChar);
printf("      GlShort:   %d\n", GlShort);
printf("      GlInt:     %d\n", GlInt);
printf("      GlLongLong: %lld\n", GlLongLong);
return 0;
}

```

Listing 2-12. IntegerAddition_.asm

```

.model flat,c

; These are defined in IntegerAddition.cpp
extern GlChar:byte
extern GlShort:word
extern GlInt:dword
extern GlLongLong:qword

; extern "C" void IntegerTypes_(char a, short b, int c, long long d);
;
; Description: This function demonstrates simple addition using
;              various-sized integers.
;
; Returns: None.

.code
IntegerAddition_ proc

; Function prolog
push ebp
mov ebp,esp

; Compute GlChar += a
mov al,[ebp+8]
add [GlChar],al

; Compute GlShort += b, note offset of 'b' on stack
mov ax,[ebp+12]
add [GlShort],ax

; Compute GlInt += c, note offset of 'c' on stack
mov eax,[ebp+16]
add [GlInt],eax

; Compute GlLongLong += d, note use of dword ptr operator and adc
mov eax,[ebp+20]
mov edx,[ebp+24]
add dword ptr [GlLongLong],eax
adc dword ptr [GlLongLong+4],edx

```

```

; Function epilog
    pop ebp
    ret
IntegerAddition_ endp
end

```

The C++ portion of this sample program defines four global signed integers using different fundamental types. Note that each variable definition includes the string "C", which instructs the compiler to use C-style names instead of C++ decorated names when generating public symbols for use by the linker. The C++ file also contains a declaration for the assembly language function `IntegerAddition_`. This function performs some simple integer addition using the four global variables.

Near the top of the file `IntegerAddition_.asm` are four `extern` statements. Similar to its C++ counterpart, the `extern` directive notifies the assembler that the named variable is defined outside the scope of the current file. Each `extern` directive also includes the fundamental type of the variable. The `extern` directive can also include a language type specifier to override the default type that's specified by the `.model flat,c` directive. Later in this chapter, you'll learn how to use the `extern` directive to reference external functions.

Following the prolog, the function `IntegerAdditions_` loads argument `a` into register `AL` and then computes `GIChar += a` using an `add [GIChar],al` instruction. In a similar manner, the calculation of `GIShort += b` is performed next using register `AX` with an important distinction; the stack offset of parameter `b` is `+12` and not `+9` as you might expect. The reason for this is that Visual C++ size extends 8-bit and 16-bit values to 32 bits before pushing them onto the stack, as illustrated in Figure 2-4. This ensures that the stack pointer register `ESP` is always properly aligned to a 32-bit boundary.

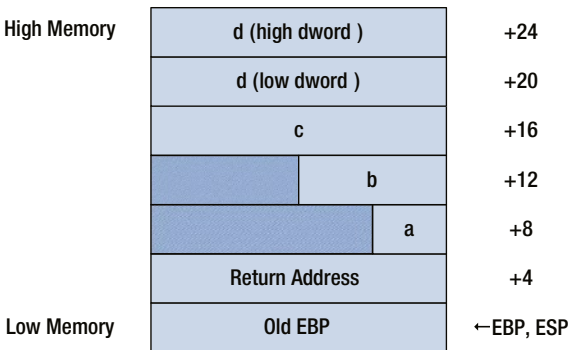

Figure 2-4. Organization of stack arguments in the function `IntegerAdditions_`

An `add [GIInt],eax` instruction is then used to calculate `GIInt += c`. The stack offset of `c` is `+16`, which is not two but four bytes greater than the offset of `b`. The final calculation, `GILongLong += d`, is carried out using two 32-bit add instructions. The `add dword ptr [GILongLong],eax` instruction adds the lower-order doublewords; the `adc dword ptr [GILongLong+4],edx` (Add With Carry) instruction completes the 64-bit

add operation. Two separate add instructions are used here since x86-32 mode does not support addition using 64-bit operands. The add and adc instructions also include a `dword ptr` operator since the variable `GLLongLong` is declared as a quadword type. Output 2-5 exhibits the output for the sample program called `IntegerAddition`.

Output 2-5. Sample Program `IntegerAddition`

```
Before  GLChar:    10
        GLShort:   20
        GLInt:     30
        GLLongLong: 4294967294

After   GLChar:    13
        GLShort:   25
        GLInt:     -7
        GLLongLong: 4294967305
```

Condition Codes

The final sample program of this section demonstrates how to use the x86's conditional instructions including `jcc`, `cmovcc` (Conditional Move), and `setcc` (Set Byte on Condition). The execution of a conditional instruction is contingent on its specified condition code and the state of one or more status flags, as discussed in Chapter 1. You have already seen a few examples of the conditional jump instruction. The function `IntegerMulDiv_` (Listing 2-5) used a `jz` to prevent a potential division-by-zero error. In `MemoryAddressingModes_` (Listing 2-10), the `j1` and `jge` instructions were used following a `cmp` instruction to validate a table index. The sample program for this section is called `ConditionCodes` and the Visual Studio solution file is named `Chapter02\ConditionCodes\ConditionCodes.sln`. Listings 2-13 and 2-14 show the source code for `ConditionCodes.cpp` and `ConditionCodes_.asm`, respectively.

Listing 2-13. `ConditionCodes.cpp`

```
#include "stdafx.h"

extern "C" int SignedMinA_(int a, int b, int c);
extern "C" int SignedMaxA_(int a, int b, int c);
extern "C" int SignedMinB_(int a, int b, int c);
extern "C" int SignedMaxB_(int a, int b, int c);

int _tmain(int argc, _TCHAR* argv[])
{
    int a, b, c;
    int smin_a, smax_a;
    int smin_b, smax_b;
```

```

// SignedMin examples
a = 2; b = 15; c = 8;
smin_a = SignedMinA(a, b, c);
smin_b = SignedMinB(a, b, c);
printf("SignedMinA(%4d, %4d, %4d) = %4d\n", a, b, c, smin_a);
printf("SignedMinB(%4d, %4d, %4d) = %4d\n\n", a, b, c, smin_b);

a = -3; b = -22; c = 28;
smin_a = SignedMinA(a, b, c);
smin_b = SignedMinB(a, b, c);
printf("SignedMinA(%4d, %4d, %4d) = %4d\n", a, b, c, smin_a);
printf("SignedMinB(%4d, %4d, %4d) = %4d\n\n", a, b, c, smin_b);

a = 17; b = 37; c = -11;
smin_a = SignedMinA(a, b, c);
smin_b = SignedMinB(a, b, c);
printf("SignedMinA(%4d, %4d, %4d) = %4d\n", a, b, c, smin_a);
printf("SignedMinB(%4d, %4d, %4d) = %4d\n\n", a, b, c, smin_b);

// SignedMax examples
a = 10; b = 5; c = 3;
smax_a = SignedMaxA(a, b, c);
smax_b = SignedMaxB(a, b, c);
printf("SignedMaxA(%4d, %4d, %4d) = %4d\n", a, b, c, smax_a);
printf("SignedMaxB(%4d, %4d, %4d) = %4d\n\n", a, b, c, smax_b);

a = -3; b = 28; c = 15;
smax_a = SignedMaxA(a, b, c);
smax_b = SignedMaxB(a, b, c);
printf("SignedMaxA(%4d, %4d, %4d) = %4d\n", a, b, c, smax_a);
printf("SignedMaxB(%4d, %4d, %4d) = %4d\n\n", a, b, c, smax_b);

a = -25; b = -37; c = -17;
smax_a = SignedMaxA(a, b, c);
smax_b = SignedMaxB(a, b, c);
printf("SignedMaxA(%4d, %4d, %4d) = %4d\n", a, b, c, smax_a);
printf("SignedMaxB(%4d, %4d, %4d) = %4d\n\n", a, b, c, smax_b);
}

```

Listing 2-14. ConditionCodes.asm

```

.model flat,c
.code

; extern "C" int SignedMinA(int a, int b, int c);
;
; Description: Determines minimum of three signed integers
;              using conditional jumps.
;
; Returns      min(a, b, c)

```

```

SignedMinA_proc
    push ebp
    mov ebp,esp
    mov eax,[ebp+8]           ;eax = 'a'
    mov ecx,[ebp+12]        ;ecx = 'b'

; Determine min(a, b)
    cmp eax,ecx
    jle @F
    mov eax,ecx              ;eax = min(a, b)

; Determine min(a, b, c)
@@:    mov ecx,[ebp+16]      ;ecx = 'c'
    cmp eax,ecx
    jle @F
    mov eax,ecx              ;eax = min(a, b, c)

@@:    pop ebp
    ret
SignedMinA_endp

; extern "C" int SignedMaxA_(int a, int b, int c);
;
; Description: Determines maximum of three signed integers
;              using conditional jumps.
;
; Returns:     max(a, b, c)

SignedMaxA_proc
    push ebp
    mov ebp,esp
    mov eax,[ebp+8]         ;eax = 'a'
    mov ecx,[ebp+12]       ;ecx = 'b'

    cmp eax,ecx
    jge @F
    mov eax,ecx             ;eax = max(a, b)

@@:    mov ecx,[ebp+16]     ;ecx = 'c'
    cmp eax,ecx
    jge @F
    mov eax,ecx             ;eax = max(a, b, c)

@@:    pop ebp
    ret
SignedMaxA_endp

```



```

; extern "C" int SignedMinB_(int a, int b, int c);
;
; Description: Determines minimum of three signed integers
;             using conditional moves.
;
; Returns      min(a, b, c)

SignedMinB_ proc
    push ebp
    mov ebp,esp
    mov eax,[ebp+8]           ;eax = 'a'
    mov ecx,[ebp+12]         ;ecx = 'b'

; Determine smallest value using the CMOVG instruction
    cmp eax,ecx
    cmovg eax,ecx           ;eax = min(a, b)
    mov ecx,[ebp+16]        ;ecx = 'c'
    cmp eax,ecx
    cmovg eax,ecx           ;eax = min(a, b, c)

    pop ebp
    ret
SignedMinB_ endp

; extern "C" int SignedMaxB_(int a, int b, int c);
;
; Description: Determines maximum of three signed integers
;             using conditional moves.
;
; Returns:     max(a, b, c)

SignedMaxB_ proc
    push ebp
    mov ebp,esp
    mov eax,[ebp+8]         ;eax = 'a'
    mov ecx,[ebp+12]        ;ecx = 'b'

; Determine largest value using the CMOVL instruction
    cmp eax,ecx
    cmovl eax,ecx           ;eax = max(a, b)
    mov ecx,[ebp+16]        ;ecx = 'c'
    cmp eax,ecx
    cmovl eax,ecx           ;eax = max(a, b, c)

    pop ebp
    ret
SignedMaxB_ endp
end

```

When developing code to implement a particular algorithm, it is often necessary to determine the minimum or maximum value of two numbers. Visual C++ defines two macros called `__min` and `__max` to perform these operations. The file `ConditionCodes.asm` contains several three-argument versions of signed-integer minimum and maximum functions. The purpose of these functions is to illustrate proper use of the `jcc` and `cmovcc` instructions.

The first function, called `SignedMinA_`, finds the minimum value of three signed integers. Following the function's prolog, the first code block determines `min(a, b)` using two instructions: `cmp eax,ecx` and `jle @F`. The `cmp` instruction, which you saw earlier in this chapter, subtracts the source operand from the destination operand and sets the status flags based on the result (the result is not saved to the destination operand). The target of the `jle` (Jump if Less or Equal) instruction, `@F`, is an assembler symbol that designates nearest forward `@@` label as the target of the conditional jump (the symbol `@B` can be used for backward jumps). Following the calculation of `min(a, b)`, the next code block determines `min(min(a, b), c)` using the same technique. With the result already present in register `EAX`, `SignedMinA_` can execute its epilog code and return to the caller.

The function `SignedMaxA_` uses the same method to find the maximum of three signed integers. The only difference between `SignedMaxA_` and `SignedMinA_` is the use of a jump if a `jge` (Jump if Greater or Equal) instead of a `jle` instruction.

Versions of the functions `SignedMinA_` and `SignedMaxA_` that operate on unsigned integers can be easily created by changing the `jle` and `jge` instructions to `jbe` (Jump if Below or Equal) and `jae` (Jump if Above or Equal), respectively. Recall from the discussion in Chapter 1 that condition codes using the words "greater" and "less" are used with signed-integer operands, while "above" and "below" are used with unsigned-integer operands.

The file `SignedMinMax.asm` also contains the functions `SignedMinB_` and `SignedMaxB_`. These functions determine the minimum and maximum of three signed integers using conditional move instructions instead of conditional jumps. The `cmovcc` instruction tests the specified condition and if it's true, the source operand is copied to the destination operand. If the specified condition is false, the destination operand is not altered.

If you examine the function `SignedMaxB_`, you will notice that following each `cmp eax,ecx` instruction is a `cmovg eax,ecx` instruction. The `cmovg` instruction copies the contents of `ECX` to `EAX` if `EAX` is greater than `ECX`. The same technique is used in `SignedMinB_`, which employs `cmovl` instead of `cmovg` to save the smaller signed integer. Unsigned versions of these functions can be easily created by using `cmova` and `cmovb` instead of `cmovg` and `cmovl`, respectively. The output for the sample program `ConditionCodes` is shown in Output 2-6.

Output 2-6. Sample Program `ConditionCodes`

```
SignedMinA( 2, 15, 8) = 2
SignedMinB( 2, 15, 8) = 2

SignedMinA( -3, -22, 28) = -22
SignedMinB( -3, -22, 28) = -22

SignedMinA( 17, 37, -11) = -11
SignedMinB( 17, 37, -11) = -11
```

```

SignedMaxA( 10, 5, 3) = 10
SignedMaxB( 10, 5, 3) = 10

SignedMaxA( -3, 28, 15) = 28
SignedMaxB( -3, 28, 15) = 28

SignedMaxA( -25, -37, -17) = -17
SignedMaxB( -25, -37, -17) = -17

```

The use of a conditional move instruction to eliminate one or more conditional jump statements frequently results in faster code, especially in situations where the processor is unable to accurately predict whether the jump will be performed. Chapter 21 will examine some of the issues related to optimal use of conditional jump instructions in greater detail.

The final conditional instruction that you'll look at is the `setcc` instruction. As implied by its name, the `setcc` instruction sets an 8-bit destination operand to 1 if the tested condition is true; otherwise, the destination operand is set to 0. This instruction is useful for functions that return or set a `bool` value, as illustrated in Listing 2-15. You'll see additional examples of the `setcc` instruction later in this book.

Listing 2-15. Example for Set byte on condition instruction

```

; extern "C" bool SignedIsEQ_(int a, int b);

SignedIsEQ_ proc
    push ebp
    mov ebp,esp

    xor eax,eax
    mov ecx,[ebp+8]
    cmp ecx,[ebp+12]
    sete al

    pop ebp
    ret
SignedIsEQ_ endp

```

Arrays

Arrays are an indispensable data construct in virtually all programming languages. In C++ there is an inherent connection between arrays and pointers since the name of an array is essentially a pointer to its first element. Moreover, whenever an array is used as a C++ function parameter, a pointer is passed instead of duplicating the array on the stack. Pointers are also employed for arrays that are dynamically allocated at run-time. This section examines some x86-32 assembly language functions that operate on arrays. The first sample program reveals how to access the elements of a one-dimensional array; the second sample program demonstrates element processing using an input and output array; and the final example illustrates some techniques for manipulating the elements of a two-dimensional array.

Before examining the sample programs, let's quickly review some C++ array concepts. Consider the simple program that is shown in Listing 2-16. In the function `CalcArrayCubes`, the elements of arrays `x` and `y` are stored in contiguous blocks of memory on the stack. Invocation of the function `CalcArrayCubes` causes the compiler to push three arguments onto the stack from right to left: the value of `n`, a pointer to the first element of `x`, and a pointer to the first element of `y`. The `for` loop of function `CalcArrayCubes` contains the statement `int temp= x[i]`, which assigns the value of the *i*-th element of array `x` to `temp`. The memory address of this element is simply the sum of `x` and `i * 4` since the size of an `int` is four bytes. The same method is also used to calculate the address of an element in the `y` array.

Listing 2-16. `CalcArrayCubes.cpp`

```
#include "stdafx.h"

void CalcArrayCubes(int* y, const int* x, int n)
{
    for (int i = 0; i < n; i++)
    {
        int temp = x[i];
        y[i] = temp * temp * temp;
    }
}

int _tmain(int argc, _TCHAR* argv[])
{
    int x[] = { 2, 7, -4, 6, -9, 12, 10 };
    const int n = sizeof(x) / sizeof(int);
    int y[n];

    CalcArrayCubes(y, x, n);

    for (int i = 0; i < n; i++)
        printf("i: %4d x: %4d y: %4d\n", i, x[i], y[i]);
    printf("\n");

    return 0;
}
```

One-Dimensional Arrays

This section examines a couple of sample programs that demonstrate using x86 assembly language with one-dimensional arrays. The first sample program is called `CalcArraySum`. This program contains a function that calculates the sum of an integer array. It also illustrates how to iteratively access each element of an array. The source code for files `CalArraySum.cpp` and `CalcArraySum_.asm` are shown in Listings 2-17 and 2-18, respectively.

Listing 2-17. CalcArraySum.cpp

```

#include "stdafx.h"

extern "C" int CalcArraySum_(const int* x, int n);

int CalcArraySumCpp(const int* x, int n)
{
    int sum = 0;

    for (int i = 0; i < n; i++)
        sum += *x++;

    return sum;
}

int _tmain(int argc, _TCHAR* argv[])
{
    int x[] = {1, 7, -3, 5, 2, 9, -6, 12};
    int n = sizeof(x) / sizeof(int);

    printf("Elements of x[]\n");
    for (int i = 0; i < n; i++)
        printf("%d ", x[i]);
    printf("\n\n");

    int sum1 = CalcArraySumCpp(x, n);
    int sum2 = CalcArraySum_(x, n);

    printf("sum1: %d\n", sum1);
    printf("sum2: %d\n", sum2);
    return 0;
}

```

Listing 2-18. CalcArraySum_.asm

```

        .model flat,c
        .code

; extern "C" int CalcArraySum_(const int* x, int n);
;
; Description: This function sums the elements of a signed
;              integer array.

CalcArraySum_ proc
    push ebp
    mov ebp,esp

```

```

; Load arguments and initialize sum
    mov edx,[ebp+8]           ;edx = 'x'
    mov ecx,[ebp+12]        ;ecx = 'n'
    xor eax,eax              ;eax = sum

; Make sure 'n' is greater than zero
    cmp ecx,0
    jle InvalidCount

; Calculate the array element sum
@@:  add eax,[edx]             ;add next element to sum
     add edx,4               ;set pointer to next element
     dec ecx                 ;adjust counter
     jnz @B                  ;repeat if not done

InvalidCount:
    pop ebp
    ret
CalcArraySum_ endp
    end

```

■ **Note** The Visual Studio solution files for the remaining sample code in this chapter and beyond use the following naming convention: Chapter##\<ProgramName>\<ProgramName>.sln, where ## denotes the chapter number and <ProgramName> represents the name of the sample program.

The C++ portion of the sample program `CalcArraySum` (Listing 2-17) includes a test function called `CalcArraySumCpp` that sums the elements of a signed-integer array. While hardly necessary in this case, coding a function using C++ first followed by its x86 assembly language equivalent is often helpful during software testing and debugging. The assembly language function `CalcArraySum_` (Listing 2-18) computes the same result as `CalcArraySumCpp`. Following its function prolog, a pointer to array `x` is loaded into register `EDX`. Next, the argument value of `n` is copied into `ECX`. This is followed by an `xor eax, eax` (Logical Exclusive OR) instruction, which initializes the running sum to 0.

Sweeping through the array to sum the elements requires only four instructions. The `add eax, [edx]` instruction adds the current array element to the running sum. Four is then added to register `EDX`, which points it to the next element in the array. A `dec ecx` instruction subtracts 1 from the counter and updates the state of `EFLAGS.ZF`. This enables the `jnz` (Jump if not Zero) instruction to terminate the loop after all `n` elements have been summed. The instruction sequence employed here to calculate the array sum is the assembly language equivalent of the `for` loop that was used by the function `CalcArraySumCpp`. The output for the sample program `CalcArraySum` is shown in Output 2-7.

Output 2-7. Sample Program CalcArraySum

```

Elements of x[]
1 7 -3 5 2 9 -6 12

sum1: 27
sum2: 27

```

When working with arrays, it is frequently necessary to define functions that perform element-by-element transformations. You saw an example of this in the function CalcArrayCubes (Listing 2-16), which cubed each element of an input array and saved the results to a separate output array. The next sample program, named CalcArraySquares, exemplifies how to code an assembly-language function to perform similar processing. Listings 2-19 and 2-20 show the source code for CalcArraySquares.cpp and CalcArraySquares_.asm, respectively.

Listing 2-19. CalcArraySquares.cpp

```

#include "stdafx.h"

extern "C" int CalcArraySquares_(int* y, const int* x, int n);

int CalcArraySquaresCpp(int* y, const int* x, int n)
{
    int sum = 0;

    for (int i = 0; i < n; i++)
    {
        y[i] = x[i] * x[i];
        sum += y[i];
    }

    return sum;
}

int _tmain(int argc, _TCHAR* argv[])
{
    int x[] = {2, 3, 5, 7, 11, 13, 17, 19, 23, 29};
    const int n = sizeof(x) / sizeof(int);
    int y1[n];
    int y2[n];
    int sum_y1 = CalcArraySquaresCpp(y1, x, n);
    int sum_y2 = CalcArraySquares_(y2, x, n);

    for (int i = 0; i < n; i++)
        printf("i: %2d x: %4d y1: %4d y2: %4d\n", i, x[i], y1[i], y2[i]);
    printf("\n");
}

```

```

printf("sum_y1: %d\n", sum_y1);
printf("sum_y2: %d\n", sum_y2);

return 0;
}

```

Listing 2-20. CalcArrayCubes.cpp

```

.model flat,c
.code

; extern "C" int CalcArraySquares_(int* y, const int* x, int n);
;
;Description: This function computes y[i] = x[i] * x[i].
;
; Returns: Sum of the elements in array y.

CalcArraySquares_ proc
    push ebp
    mov ebp,esp
    push ebx
    push esi
    push edi

; Load arguments
    mov edi,[ebp+8]           ;edi = 'y'
    mov esi,[ebp+12]        ;esi = 'x'
    mov ecx,[ebp+16]        ;ecx = 'n'

; Initialize array sum register, calculate size of array in bytes,
; and initialize element offset register.
    xor eax,eax             ;eax = sum of 'y' array
    cmp ecx,0
    jle EmptyArray
    shl ecx,2              ;ecx = size of array in bytes
    xor ebx,ebx            ;ebx = array element offset

; Repeat loop until finished
@@: mov edx,[esi+ebx]       ;load next x[i]
    imul edx,edx           ;compute x[i] * x[i]
    mov [edi+ebx],edx      ;save result to y[i]
    add eax,edx            ;update running sum
    add ebx,4              ;update array element offset
    cmp ebx,ecx
    jl @@B                ;jump if not finished

```



```

EmptyArray:
    pop edi
    pop esi
    pop ebx
    pop ebp
    ret
CalcArraySquares_ endp
end

```

The function `CalcArraySquares_` (Listing 2-20) computes the square of each element in array `x` and saves this result to the corresponding element in array `y`. It also computes the sum of the elements in `y`. Following the function prolog, registers `ESI` and `EDI` are initialized as pointers to `x` and `y`, respectively. The function also loads `n` into register `ECX` and initializes `EAX`, which will be used to compute the sum, to zero. Following a validity check of `n`, the size of the array in bytes is calculated using a `shl ecx, 2` instruction. This value will be used to terminate the processing loop. The function then initializes register `EBX` to zero and will use this register as an offset into both `x` and `y`.

The processing loop uses a `mov edx, [esi+ebx]` instruction to load `x[i]` into register `EDX` and then computes the square using the two-operand form of `imul`. This value is then saved to `y[i]` using a `mov [edi+ebx], edx` instruction. An `add eax, edx` instruction adds `y[i]` to the running sum in register `EAX`. The offset of the next element in both `x` and `y` is computed using an `add ebx, 4` instruction. The processing loop repeats as long as the offset value in register `EBX` is less than the size in bytes of the arrays, which resides in register `ECX`. Output 2-8 shows the results of `CalcArraySquares`.

Output 2-8. Sample Program `CalcArraySquares`

```

i: 0 x:  2 y1:  4 y2:  4
i: 1 x:  3 y1:  9 y2:  9
i: 2 x:  5 y1: 25 y2: 25
i: 3 x:  7 y1: 49 y2: 49
i: 4 x: 11 y1:121 y2:121
i: 5 x: 13 y1:169 y2:169
i: 6 x: 17 y1:289 y2:289
i: 7 x: 19 y1:361 y2:361
i: 8 x: 23 y1:529 y2:529
i: 9 x: 29 y1:841 y2:841

```

```
sum_y1: 2397
```

```
sum_y2: 2397
```

Two-Dimensional Arrays

In C++ it is possible to use a contiguous block of memory to store the elements of a two-dimensional array or matrix. This enables the compiler to generate code that uses simple pointer arithmetic to uniquely access each matrix element. It also allows the programmer to manually perform the same pointer arithmetic when working with a

matrix. The sample program in this section demonstrates using x86 assembly language to access the elements of a matrix. Before you examine the source code files, you'll take a closer look at how C++ handles matrices in memory.

C++ uses row-major ordering to organize the elements of a two-dimensional matrix in memory. Row-major ordering arranges the elements of a matrix first by row and then by column. For example, elements of the matrix `int x[3][2]` are stored in memory as follows: `x[0][0]`, `x[0][1]`, `x[1][0]`, `x[1][1]`, `x[2][0]`, and `x[2][1]`. In order to access a specific element in the matrix, a C++ compiler must know the row and column indices, the total number of columns, and the starting address. Using this information, an element can be accessed using pointer arithmetic, as illustrated in Listing 2-21.

Listing 2-21. `CalcMatrixCubes.cpp`

```
#include "stdafx.h"

void CalcMatrixCubes(int* y, const int* x, int nrows, int ncols)
{
    for (int i = 0; i < nrows; i++)
    {
        for (int j = 0; j < ncols; j++)
        {
            int k = i * ncols + j;
            y[k] = x[k] * x[k] * x[k];
        }
    }
}

int _tmain(int argc, _TCHAR* argv[])
{
    const int nrows = 4;
    const int ncols = 3;
    int x[nrows][ncols] = { { 1, 2, 3 }, { 4, 5, 6 }, { 7, 8, 9 },
    ↪ { 10, 11, 12 } };
    int y[nrows][ncols];

    CalcMatrixCubes(&y[0][0], &x[0][0], nrows, ncols);

    for (int i = 0; i < nrows; i++)
    {
        for (int j = 0; j < ncols; j++)
            printf("(%2d, %2d): %6d, %6d\n", i, j, x[i][j], y[i][j]);
    }

    return 0;
}
```

In function `CalcMatrixCubes` (Listing 2-21), the offset of a specific matrix element is uniquely determined by the formula $i * \text{ncols} + j$, where i and j correspond to the row and column indices of the element. Following calculation of the offset, the matrix element can be referenced using the same syntax that is used to reference an element of a one-dimensional array. The sample program for this section, which is called `CalcMatrixRowColSums`, uses this technique to sum the rows and columns of a matrix. Listings 2-22 and 2-23 show the source code for files `CalcMatrixRowColSums.cpp` and `CalcMatrixRowColSums.asm`.

Listing 2-22. `CalcMatrixRowColSums.cpp`

```
#include "stdafx.h"
#include <stdlib.h>

// The function PrintResults is defined in CalcMatrixRowColSumsMisc.cpp
extern void PrintResults(const int* x, int nrows, int ncols, int* row_sums,
↳ int* col_sums);

extern "C" int CalcMatrixRowColSums_(const int* x, int nrows, int ncols,
↳ int* row_sums, int* col_sums);

void CalcMatrixRowColSumsCpp(const int* x, int nrows, int ncols, int*
↳ row_sums, int* col_sums)
{
    for (int j = 0; j < ncols; j++)
        col_sums[j] = 0;

    for (int i = 0; i < nrows; i++)
    {
        row_sums[i] = 0;
        int k = i * ncols;

        for (int j = 0; j < ncols; j++)
        {
            int temp = x[k + j];
            row_sums[i] += temp;
            col_sums[j] += temp;
        }
    }
}

int _tmain(int argc, _TCHAR* argv[])
{
    const int nrows = 7, ncols = 5;
    int x[nrows][ncols];
```

```

// Initialize the test matrix
srand(13);
for (int i = 0; i < nrows; i++)
{
    for (int j = 0; j < ncols; j++)
        x[i][j] = rand() % 100;
}

// Calculate the row and column sums
int row_sums1[nrows], col_sums1[ncols];
int row_sums2[nrows], col_sums2[ncols];

CalcMatrixRowColSumsCpp((const int*)x, nrows, ncols, row_sums1,
↳ col_sums1);
printf("\nResults using CalcMatrixRowColSumsCpp()\n");
PrintResults((const int*)x, nrows, ncols, row_sums1, col_sums1);

CalcMatrixRowColSums_((const int*)x, nrows, ncols, row_sums2,
↳ col_sums2);
printf("\nResults using CalcMatrixRowColSums_()\n");
PrintResults((const int*)x, nrows, ncols, row_sums2, col_sums2);

return 0;
}

```

Listing 2-23. CalcMatrixRowColSums_.asm

```

.model flat,c
.code

; extern "C" int CalcMatrixRowColSums_(const int* x, int nrows, int ncols,
↳↳ int* row_sums, int* col_sums);
;
; Description: The following function sums the rows and columns
;               of a 2-D matrix.
;
; Returns:      0 = 'nrows' or 'ncols' is invalid
;               1 = success

CalcMatrixRowColSums_ proc
    push ebp
    mov ebp,esp
    push ebx
    push esi
    push edi

```

```

; Make sure 'nrow' and 'ncol' are valid
xor eax,eax                               ;error return code
cmp dword ptr [ebp+12],0                  ;[ebp+12] = 'nrows'
jle InvalidArg                            ;jump if nrows <= 0
mov ecx,[ebp+16]                          ;ecx = 'ncols'
cmp ecx,0
jle InvalidArg                            ;jump if ncols <= 0

; Initialize elements of 'col_sums' array to zero
mov edi,[ebp+24]                          ;edi = 'col_sums'
xor eax,eax                               ;eax = fill value
rep stosd                                 ;fill array with zeros

; Initialize outer loop variables
mov ebx,[ebp+8]                            ;ebx = 'x'
xor esi,esi                               ;i = 0

; Outer loop
Lp1:  mov edi,[ebp+20]                      ;edi = 'row_sums'
      mov dword ptr [edi+esi*4],0          ;row_sums[i] = 0

      xor edi,edi                          ;j = 0
      mov edx,esi                          ;edx = i
      imul edx,[ebp+16]                    ;edx = i * ncols

; Inner loop
Lp2:  mov ecx,edx                          ;ecx = i * ncols
      add ecx,edi                          ;ecx = i * ncols + j
      mov eax,[ebx+ecx*4]                  ;eax = x[i * ncols + j]
      mov ecx,[ebp+20]                    ;ecx = 'row_sums'
      add [ecx+esi*4],eax                  ;row_sums[i] += eax
      mov ecx,[ebp+24]                    ;ecx = 'col_sums'
      add [ecx+edi*4],eax                  ;col_sums[j] += eax

; Is inner loop finished?
inc edi                                    ;j++
cmp edi,[ebp+16]                          ;jump if j < ncols
jl Lp2

; Is outer loop finished?
inc esi                                    ;i++
cmp esi,[ebp+12]                          ;jump if i < nrows
jl Lp1
mov eax,1                                  ;set success return code

```

```

InvalidArg:
    pop edi
    pop esi
    pop ebx
    pop ebp
    ret
CalcMatrixRowColSums_ endp
end

```

Start by taking a look at the C++ implementation of the row-column summing algorithm. Listing 2-22 contains a function named `CalcMatrixRowColSumsCpp`. This function sweeps through an input matrix `x` and during each iteration, it adds the current matrix element to the appropriate entries in the arrays `row_sums` and `col_sums`. Function `CalcMatrixRowColSumsCpp` uses the previously-described pointer arithmetic technique to uniquely reference a matrix element.

Listing 2-23 shows the assembly language version of the row-column summing algorithm. Following the function prolog, the arguments `nrows` and `ncols` are tested for validity. The elements of `col_sums` are then initialized to zero using a `rep stosd` (Repeat Store String Doubleword) instruction. The `stosd` instruction stores the contents of EAX to the memory location specified by EDI; it then updates EDI to point to the next array element. The `rep` mnemonic is an instruction prefix that tells the processor to repeat the store operation using ECX as a counter. After each store operation, ECX is decremented by 1; `stosd` execution continues until ECX equals zero. You'll take a closer look at the x86 string processing instructions later in this chapter.

The function `CalcMatrixRowColSums_` uses register EBX to hold the base address of the input matrix `x`. Registers ESI and EDI contain the row and column indices, respectively. Each outer loop starts by initializing `row_sums[i]` to zero and computing a value for `k`. Within the inner loop, the final offset for the current matrix element is calculated. This matrix element is loaded into EAX using a `mov eax, [ebx+ecx*4]` instruction. Next, the function adds EAX to the corresponding entries in the arrays `row_sums` and `col_sums`. This process is repeated until all of the elements in matrix `x` have been added to the total arrays. Note that the function `CalcMatrixRowColSums` makes extensive use of `BaseReg+IndexReg*ScaleFactor` memory addressing, which simplifies the loading of elements from matrix `x` and the updating of elements in both `row_sums` and `col_sums`, as shown in Figure 2-5. The results of `CalcMatrixRowColSums` are shown in Output 2-9.

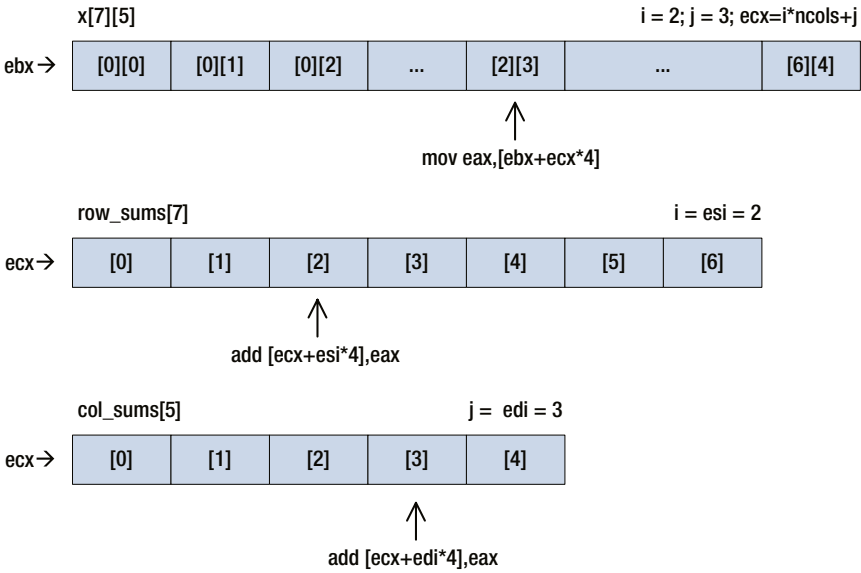

Figure 2-5. Memory addressing used in the function `CalcMatrixRowColSums_`

Output 2-9. Sample Program `CalcMatrixRowColSums`

```
Results using CalcMatrixRowColSumsCpp()
 81  76  96  48  72  --  373
 76  59  99  93  23  --  350
 30  73   4  75  23  --  205
 40  99  69  96  88  --  392
 37  67  40  92  88  --  324
 15  80  16  62  72  --  245
 90  23   4  55  22  --  194

369  477  328  521  388

Results using CalcMatrixRowColSums_( )
 81  76  96  48  72  --  373
 76  59  99  93  23  --  350
 30  73   4  75  23  --  205
 40  99  69  96  88  --  392
 37  67  40  92  88  --  324
 15  80  16  62  72  --  245
 90  23   4  55  22  --  194

369  477  328  521  388
```

Structures

A structure is a programming language construct that enables a programmer to define new data types using one or more existing data types. Both Visual C++ and MASM support structures. In this section, you'll learn how to use a common structure definition in both a C++ and assembly language function. You'll also explore some of the issues that developers need to be aware of when defining a structure that will be used by software written using different languages. Besides basic structure use, the sample programs of this section demonstrate how to call standard C++ library functions from an x86 assembly language function. You'll also learn how to use a few more x86-32 assembly language instructions.

In C++ a structure is equivalent to a class. When a data type is defined using the keyword `struct` instead of `class`, all members are public by default. Another option for structure definition is to use C-style definitions such as `typedef struct { ... } MyStruct;`. This style is suitable for simple data-only structures and will be used by the sample programs in this section. C++ structure definitions are usually placed in header files so they can be easily referenced by multiple files. The same technique is also used to define and reference structures that are used in assembly language functions. Unfortunately, it is not possible to define a single structure in a header file and include this file in both C++ and assembly-language source code files. If you want to use the "same" structure in both C++ and assembly language, it must be defined twice and both definitions must be semantically equivalent.

Simple Structures

The first sample program that you'll study is called `CalcStructSum`. This program demonstrates basic structure use between two functions: one written using C++ and the other written using x86 assembly language. Let's begin by defining a simple structure that will be used by all of the sample programs in this section. Listings 2-24 and 2-25 each contain a structure definition named `TestStruct`.

Listing 2-24. `TestStruct.h`

```
typedef struct
{
    __int8  Val8;
    __int8  Pad8;
    __int16 Val16;
    __int32 Val32;
    __int64 Val64;
} TestStruct;
```

Listing 2-25. TestStruct_.inc

```

TestStruct struct
Val8    byte ?
Pad8    byte ?
Val16   word ?
Val32   dword ?
Val64   qword ?
TestStruct ends

```

The C++ definition of TestStruct (Listing 2-24) uses sized integer types instead of the more common ANSI types. Some developers (including me) prefer to use sized integer types for assembly language structures and function arguments since it emphasizes the exact size of the data types that are being manipulated. The other noteworthy detail regarding TestStruct is the definition of structure member Pad8. While not explicitly required, the inclusion of this member helps document the fact that the C++ compiler defaults to aligning structure members to their natural boundaries. The assembly language version of TestStruct (Listing 2-25) looks similar to its C++ counterpart. The biggest difference between the two is that the assembler *does not* automatically align structure members to their natural boundaries. Here the definition of Pad8 is required; without the member Pad8, the C++ and assembly language versions would be semantically different. The ? symbol that's included with each data element declaration notifies the assembler to perform storage allocation only and is customarily used to remind the programmer that structure members are always uninitialized.

The C++ and assembly language source code for the sample program CalcStructSum are shown in Listings 2-26 and 2-27, respectively. The C++ portion of this program is straightforward. The function `_tmain` declares an instance of TestStruct named `ts`. Following initialization of `ts`, the function `CalcStructSumCpp` is called, which sums the members of `ts` and returns a 64-bit integer result. The function `_tmain` then calls the assembly language function `CalcStructSum_` to perform the same member-summing calculation.

Listing 2-26. CalcStructSum.cpp

```

#include "stdafx.h"
#include "TestStruct.h"

extern "C" __int64 CalcStructSum_(const TestStruct* ts);

__int64 CalcStructSumCpp(const TestStruct* ts)
{
    return ts->Val8 + ts->Val16 + ts->Val32 + ts->Val64;
}

int _tmain(int argc, _TCHAR* argv[])
{
    TestStruct ts;

    ts.Val8 = -100;
    ts.Val16 = 2000;

```

```

ts.Val32 = -300000;
ts.Val64 = 40000000000;

__int64 sum1 = CalcStructSumCpp(&ts);
__int64 sum2 = CalcStructSum_(&ts);

printf("Input: %d %d %d %lld\n", ts.Val8, ts.Val16, ts.Val32,
↳ ↳ ts.Val64);
printf("sum1: %lld\n", sum1);
printf("sum2: %lld\n", sum2);

if (sum1 != sum2)
    printf("Sum verify check failed!\n");

return 0;
}

```

Listing 2-27. CalcStructSum_.asm

```

.model flat,c
include TestStruct_.inc
.code

; extern "C" __int64 CalcStructSum_(const TestStruct* ts);
;
; Description: This function sums the members of a TestStruct.
;
; Returns: Sum of 'ts' members as a 64-bit integer.

CalcStructSum_ proc
    push ebp
    mov ebp,esp
    push ebx
    push esi

; Compute ts->Val8 + ts->Val16, note sign extension to 32-bits
    mov esi,[ebp+8]
    movsx eax,byte ptr [esi+TestStruct.Val8]
    movsx ecx,word ptr [esi+TestStruct.Val16]
    add eax,ecx

; Sign extend previous sum to 64 bits, save result to ebx:ecx
    cdq
    mov ebx,eax
    mov ecx,edx

; Add ts->Val32 to sum
    mov eax,[esi+TestStruct.Val32]
    cdq

```

```

        add eax,ebx
        adc edx,ecx

; Add ts->Val64 to sum
        add eax,dword ptr [esi+TestStruct.Val64]
        adc edx,dword ptr [esi+TestStruct.Val64+4]

        pop esi
        pop ebx
        pop ebp
        ret
CalcStructSum_ endp
        end

```

Following its prolog, the function `CalcStructSum_` (Listing 2-27) loads register ESI with a pointer to `ts`. Two `movsx` (Move with Sign Extension) instructions then are used to load the values of structure members `ts->Val8` and `ts->Val16` into registers EAX and ECX, respectively. The `movsx` instruction creates a temporary copy of the source operand and sign-extends this value before copying it to the destination operand. As illustrated in this function, the `movsx` instruction is frequently used to load a 32-bit register using an 8-bit or 16-bit source operand. The `movsx` instructions also illustrate the syntax that is required to reference a structure member in an assembly language instruction. From the perspective of the assembler, the instruction `movsx ecx,word ptr [esi+TestStruct.Val16]` is simply an instance of `BaseReg+Disp` memory addressing since the assembler ultimately resolves the structure member identifier `TestStruct.Val16` to a constant offset value.

The function `CalcStructSum_` uses an `add eax,ecx` instruction to compute the sum of `ts->Val8` and `ts->Val16`. It then sign-extends this sum to 64 bits using a `cdq` instruction and copies the result to register pair ECX:EBX. The value of `ts->Val32` is then loaded into EAX, sign-extended into EDX:EAX, and added to the previous intermediate sum using `add` and `adc` instructions. The final structure member value `ts->Val64` is added next, which yields the final result. The Visual C++ calling convention requires 64-bit return values to be placed in register pair EDX:EAX. Since the final result is already in the required register pair, no additional `mov` instructions are necessary. Output 2-10 displays the results of the sample program `CalcStructSum`.

Output 2-10. Sample Program `CalcStructSum`

```

Input: -100 2000 -300000 40000000000
sum1: 39999701900
sum2: 39999701900

```

Dynamic Structure Creation

Many C++ programs use the `new` operator to dynamically create instances of classes or structures. For simple data-only structures like `TestStruct`, the standard library function `malloc` also can be used at run-time to allocate storage space for a new instance. In this section, you'll look at creating structures dynamically from an x86 assembly language

function. You'll also learn how to call C++ library functions from an assembly language function. The sample program for this section is named `CreateStruct`. The C++ and assembly language files are shown in Listings 2-28 and 2-29.

Listing 2-28. `CreateStruct.cpp`

```
#include "stdafx.h"
#include "TestStruct.h"

extern "C" TestStruct* CreateTestStruct(__int8 val8, __int16 val16, __int32
↳ val32, __int64 val64);
extern "C" void ReleaseTestStruct_(TestStruct* p);

void PrintTestStruct(const char* msg, const TestStruct* ts)
{
    printf("%s\n", msg);
    printf("  ts->Val8:  %d\n", ts->Val8);
    printf("  ts->Val16: %d\n", ts->Val16);
    printf("  ts->Val32: %d\n", ts->Val32);
    printf("  ts->Val64: %lld\n", ts->Val64);
}

int _tmain(int argc, _TCHAR* argv[])
{
    TestStruct* ts = CreateTestStruct_(40, -401, 400002, -4000000003LL);

    PrintTestStruct("Contents of TestStruct 'ts'", ts);

    ReleaseTestStruct_(ts);
    return 0;
}
```

Listing 2-29. `CreateStruct.asm`

```
.model flat,c
include TestStruct.inc
extern malloc:proc
extern free:proc
.code

; extern "C" TestStruct* CreateTestStruct(__int8 val8, __int16 val16,
↳ __int32 val32, __int64 val64);
;
; Description: This function allocates and initializes a new TestStruct.
;
; Returns:     A pointer to the new TestStruct or NULL error occurred.
```

```

CreateTestStruct_ proc
    push ebp
    mov ebp,esp

; Allocate a block of memory for the new TestStruct; note that
; malloc() returns a pointer to memory block in EAX
    push sizeof TestStruct
    call malloc
    add esp,4
    or eax,eax                ; NULL pointer test
    jz MallocError          ; Jump if malloc failed

; Initialize the new TestStruct
    mov dl,[ebp+8]
    mov [eax+TestStruct.Val8],dl

    mov dx,[ebp+12]
    mov [eax+TestStruct.Val16],dx

    mov edx,[ebp+16]
    mov [eax+TestStruct.Val32],edx

    mov ecx,[ebp+20]
    mov edx,[ebp+24]
    mov dword ptr [eax+TestStruct.Val64],ecx
    mov dword ptr [eax+TestStruct.Val64+4],edx

MallocError:
    pop ebp
    ret
CreateTestStruct_ endp

; extern "C" void ReleaseTestStruct_(const TestStruct* p);
;
; Description: This function release a previously created TestStruct.
;
; Returns:      None.

ReleaseTestStruct_ proc
    push ebp
    mov ebp,esp

; Call free() to release previously created TestStruct
    push [ebp+8]
    call free
    add esp,4

```

```

    pop ebp
    ret
ReleaseTestStruct_ endp
end

```

The C++ portion of sample program `CreateStruct` (Listing 2-28) is straightforward. It includes some simple test code that exercises the assembly language functions `CreateTestStruct_` and `ReleaseTestStruct_`. Near the top of the `CreateStructure_.asm` file (Listing 2-29) is the statement `extern malloc:proc`, which declares the external C++ library function `malloc`. Another `extern` statement follows for the C++ library function `free`. Unlike its C++ counterpart, the assembly language version of `extern` does not support function parameters or return types. This means that the assembler cannot perform static type checking and the programmer is responsible for ensuring that the correct arguments are placed on the stack.

Following its prolog, `CreateTestStruct_` uses the function `malloc` to allocate a memory block for a new instance of `TestStruct`. In order to use `malloc` or any C++ run-time library function, the calling function must observe the standard C++ calling convention. The instruction `push sizeof TestStruct` pushes the size in bytes of the structure `TestStruct` onto the stack. A `call malloc` instruction invokes the C++ library function. This is followed by an `add esp,4` instruction, which removes the size argument from the stack. Like all other standard functions, `malloc` uses register `EAX` for its return value. The returned pointer is tested for validity prior to its use. If the pointer returned by `malloc` is valid, the new structure instance is initialized using the provided argument values. The pointer is then returned to the caller.

The use of `malloc` by `CreateTestStruct_` means that the memory block will need to be released following its use. Requiring the caller to use the standard library function `free` would work, but this exposes the inner workings of `CreateTestStruct_` and creates an unnecessary dependency. A real-world implementation of `CreateTestStruct_` might want to manage a pool of pre-allocated `TestStruct` buffers. To allow for this possibility, the file `CreateStructure_.asm` also defines a separate function named `ReleaseTestStruct_`. In the current program, `ReleaseTestStruct_` calls `free` to release the block of memory that was previously allocated in `CreateTestStruct_`. The results of the sample program `CreateStruct` are shown in Output 2-11.

Output 2-11. Sample Program `CreateStruct`

```

Contents of TestStruct 'ts'
ts->Val8:    40
ts->Val16:   -401
ts->Val32:   400002
ts->Val64:   -4000000003

```

Strings

The x86 instruction set includes several instructions that manipulate strings. In x86 parlance, a string is a contiguous sequence of bytes, word, or doublewords. Programs can use the string instructions to process conventional text strings such as “Hello,

World.” They also can be employed to perform operations using the elements of an array or on blocks of memory. In this section, you’ll examine some sample programs that demonstrate how to use the x86 string instructions with text strings and integer arrays.

Counting Characters

The first sample program that you’ll examine in this section is named `CountChars`, which illustrates how to use the `lod`s (Load String) instruction to count the number of occurrences of a character in a text string. The source code files for this program are shown in Listings 2-30 and 2-31.

Listing 2-30. `CountChars.cpp`

```
#include "stdafx.h"

extern "C" int CountChars_(wchar_t* s, wchar_t c);

int _tmain(int argc, _TCHAR* argv[])
{
    wchar_t c;
    wchar_t* s;

    s = L"Four score and seven seconds ago, ...";
    wprintf(L"\nTest string: %s\n", s);
    c = L's';
    wprintf(L" SearchChar: %c Count: %d\n", c, CountChars_(s, c));
    c = L'F';
    wprintf(L" SearchChar: %c Count: %d\n", c, CountChars_(s, c));
    c = L'o';
    wprintf(L" SearchChar: %c Count: %d\n", c, CountChars_(s, c));
    c = L'z';
    wprintf(L" SearchChar: %c Count: %d\n", c, CountChars_(s, c));

    s = L"Red Green Blue Cyan Magenta Yellow";
    wprintf(L"\nTest string: %s\n", s);
    c = L'e';
    wprintf(L" SearchChar: %c Count: %d\n", c, CountChars_(s, c));
    c = L'w';
    wprintf(L" SearchChar: %c Count: %d\n", c, CountChars_(s, c));
    c = L'Q';
    wprintf(L" SearchChar: %c Count: %d\n", c, CountChars_(s, c));
    c = L'l';
    wprintf(L" SearchChar: %c Count: %d\n", c, CountChars_(s, c));

    return 0;
}
```

Listing 2-31. CountChars_.asm

```

.model flat,c
.code

; extern "C" int CountChars_(wchar_t* s, wchar_t c);
;
; Description: This function counts the number of occurrences
;             of 'c' in 's'
;
; Returns: Number of occurrences of 'c'

CountChars_ proc
    push ebp
    mov ebp,esp
    push esi

; Load parameters and initialize count registers
    mov esi,[ebp+8]           ;esi = 's'
    mov cx,[ebp+12]          ;cx = 'c'
    xor edx,edx              ;edx = Number of occurrences

; Repeat loop until the entire string has been scanned
@@:    lodsw                  ;load next char into ax
        or ax,ax              ;test for end-of-string
        jz @F                 ;jump if end-of-string found
        cmp ax,cx             ;test current char
        jne @B                ;jump if no match
        inc edx               ;update match count
        jmp @B

@@:    mov eax,edx            ;eax = character count
        pop esi
        pop ebp
        ret
CountChars_ endp
end

```

The assembly language function `CountChars_` accepts two arguments: a text string pointer `s` and a search character `c`. Both arguments are of type `wchar_t`, which means that each text string character and the search character are 16-bit values. The function `CountChars_` starts by loading `s` and `c` into `ESI` and `CX` respectively. `EDX` is then initialized to zero so that it can be used as an occurrence counter. The processing loop uses the `lodsw` (Load String Word) instruction to read each text string character. This instruction loads register `AX` with the contents of the memory pointed to by `ESI`; it then increments `ESI` by two so that it points to the next character. The function uses an `or ax,ax` instruction to test for the end-of-string (`'\0'`) character. If the end-of-string character is not found, a `cmp ax,cx` instruction compares the current text string character to the

search character. If a match is detected, the occurrence counter is incremented by one. This process is repeated until the end-of-string character is found. Following completion of the text string scan, the final occurrence count is moved into register EAX and returned to the caller. The results of the sample program `CountChars` are shown in Output 2-12.

Output 2-12. Sample Program `CountChars`

```
Test string: Four score and seven seconds ago, ...
```

```
SearchChar: s Count: 4
SearchChar: F Count: 1
SearchChar: o Count: 4
SearchChar: z Count: 0
```

```
Test string: Red Green Blue Cyan Magenta Yellow
```

```
SearchChar: e Count: 6
SearchChar: w Count: 1
SearchChar: Q Count: 0
SearchChar: l Count: 3
```

A version of `CountChars_` that processes strings of type `char` instead of `wchar_t` can be easily created by changing the `lodsw` instruction to a `lodsb` (Load String Byte) instruction. Register AL would also be used instead of AX. The last character of an x86 string instruction mnemonic always indicates the size of the operand that is processed.

String Concatenation

The concatenation of two text strings is a common operation that is performed by many programs. In Visual C++ applications can use the library functions `strcat`, `strcat_s`, `wcscat`, and `wcscat_s` to concatenate two strings. One drawback of these functions is that they can process only a single source string. Multiple calls are necessary if an application needs to concatenate several strings together. The next sample application of this section is called `ConcatStrings` and demonstrates how to use the `scas` (Scan String) and `movs` (Move String) instructions to concatenate multiple strings. Listing 2-32 shows the source code for `ConcatStrings.cpp` while Listing 2-33 contains the source code file for `ConcatStrings_.asm`.

Listing 2-32. `ConcatStrings.cpp`

```
#include "stdafx.h"

extern "C" int ConcatStrings_(wchar_t* des, int des_size, const wchar_t* ↵
const* src, int src_n);

int _tmain(int argc, _TCHAR* argv[])
{
    printf("\nResults for ConcatStrings\n");
```

```

// Destination buffer large enough
wchar_t* src1[] = { L"One ", L"Two ", L"Three ", L"Four" };
int src1_n = sizeof(src1) / sizeof(wchar_t*);
const int des1_size = 64;
wchar_t des1[des1_size];

int des1_len = ConcatStrings_(des1, des1_size, src1, src1_n);
wchar_t* des1_temp = (*des1 != '\0') ? des1 : L"<empty>";
wprintf(L" des_len: %d (%d) des: %s \n", des1_len, wcslen(des1_temp), ↵
des1_temp);

// Destination buffer too small
wchar_t* src2[] = { L"Red ", L"Green ", L"Blue ", L"Yellow " };
int src2_n = sizeof(src2) / sizeof(wchar_t*);
const int des2_size = 16;
wchar_t des2[des2_size];

int des2_len = ConcatStrings_(des2, des2_size, src2, src2_n);
wchar_t* des2_temp = (*des2 != '\0') ? des2 : L"<empty>";
wprintf(L" des_len: %d (%d) des: %s \n", des2_len, wcslen(des2_temp), ↵
des2_temp);

// Empty string test
wchar_t* src3[] = { L"Airplane ", L"Car ", L"", L"Truck ", L"Boat " };
int src3_n = sizeof(src3) / sizeof(wchar_t*);
const int des3_size = 128;
wchar_t des3[des3_size];

int des3_len = ConcatStrings_(des3, des3_size, src3, src3_n);
wchar_t* des3_temp = (*des3 != '\0') ? des3 : L"<empty>";
wprintf(L" des_len: %d (%d) des: %s \n", des3_len, wcslen(des3_temp), ↵
des3_temp);

return 0;
}

```

Listing 2-33. ConcatStrings_.asm

```

.model flat,c
.code

; extern "C" int ConcatStrings_(wchar_t* des, int des_size, const wchar_t* ↵
const* src, int src_n)
;
; Description: This function performs string concatenation using
;             multiple input strings.
;

```

```

; Returns:      -1          Invalid 'des_size'
;              n >=0      Length of concatenated string
;
; Locals Vars: [ebp-4] = des_index
;              [ebp-8] = i

ConcatStrings_ proc
    push ebp
    mov ebp,esp
    sub esp,8
    push ebx
    push esi
    push edi

; Make sure 'des_size' is valid
    mov eax,-1
    mov ecx,[ebp+12]                ;ecx = 'des_size'
    cmp ecx,0
    jle Error

; Perform required initializations
    xor eax,eax
    mov ebx,[ebp+8]                ;ebx = 'des'
    mov [ebx],ax                  ;*des = '\0'
    mov [ebp-4],eax                ;des_index = 0
    mov [ebp-8],eax                ;i = 0

; Repeat loop until concatenation is finished
lp1:  mov eax,[ebp+16]              ;eax = 'src'
      mov edx,[ebp-8]              ;edx = i
      mov edi,[eax+edx*4]          ;edi = src[i]
      mov esi,edi                  ;esi = src[i]

; Compute length of s[i]
    xor eax,eax
    mov ecx,-1
    repne scasd                    ;find '\0'
    not ecx
    dec ecx                          ;ecx = len(src[i])

; Compute des_index + src_len
    mov eax,[ebp-4]                ;eax= des_index
    mov edx,eax                    ;edx = des_index_temp
    add eax,ecx                     ;des_index + len(src[i])

; Is des_index + src_len >=des_size?
    cmp eax,[ebp+12]
    jge Done

```

```

; Update des_index
    add [ebp-4],ecx                ;des_index += len(src[i])

; Copy src[i] to &des[des_index] (esi already contains src[i])
    inc ecx                       ;ecx = len(src[i]) + 1
    lea edi,[ebx+edx*2]           ;edi = &des[des_index_temp]
    rep movsw                     ;perform string move

; Update i and repeat if not done
    mov eax,[ebp-8]
    inc eax
    mov [ebp-8],eax               ;i++
    cmp eax,[ebp+20]
    jl Lp1                       ;jump if i < src_n

; Return length of concatenated string
Done: mov eax,[ebp-4]             ;eax = des_index
Error: pop edi
      pop esi
      pop ebx
      mov esp,ebp
      pop ebp
      ret

ConcatStrings_ endp
end

```

Let's begin by examining the contents of `ConcatStrings.cpp` (Listing 2-31). It starts with a declaration statement for the assembly language function `ConcatStrings_`, which includes four parameters: `des` is the destination buffer for the final string; the size of `des` in characters is specified by `des_size`; and parameter `src` points to an array that contains pointers to `src_n` text strings. The function `ConcatStrings_` returns the length of `des` or -1 if the supplied value for `des_size` is less than or equal to zero.

The test cases presented in `_tmain` illustrate the use of `ConcatStrings_`. For example, if `src` points to a text string array consisting of {"Red", "Green", "Blue"}, the final string in `des` is "RedGreenBlue" assuming the size of `des` is sufficient. If the size of `des` is insufficient, `ConcatStrings_` generates a partially concatenated string. For example, a `des_size` equal to 10 would yield "RedGreen" as the final string.

The prolog of function `ConcatStrings_` (Listing 2-32) allocates space for two local variables: `des_index` is used as an offset into `des` for string copies and `i` is the index of the current string in `src`. Following a validity check of `des_size`, `ConcatStrings_` loads `des` into register `EBX` and initializes the buffer with an empty string. The values of `des_index` and `i` are then initialized to zero. The subsequent block of instructions marks the top of the concatenation loop; registers `ESI` and `EDI` are loaded with a pointer to the string `src[i]`.

The length of `src[i]` is determined next using a `repne scasw` instruction in conjunction with several support instructions. The `repne` (Repeat String Operation While not Equal) is an instruction prefix that repeats execution of a string instruction while the condition `ECX != 0 && EFLAGS.ZF == 0` is true. The exact operation of the `repne scasw`

(Scan String Word) combination is as follows: If ECX is not zero, the `scasw` instruction compares the string character pointed to by EDI to the contents of register AX and sets the status flags according to the results. Register EDI is then automatically incremented by two so that it points to the next character and a count of one is subtracted from ECX. This string-processing operation is repeated so long as the aforementioned test conditions remain true; otherwise, the repeat string operation terminates.

Prior to execution of `repne scasw`, register ECX was loaded with `-1`. Upon completion of the `repne scasw` instruction, register ECX contains `-(L + 2)`, where `L` denotes the actual string length of `src[i]`. The value `L` is calculated using a `not ecx` (One's Complement Negation) instruction followed by a `dec ecx` (Decrement by 1) instruction, which is equal to subtracting 2 from the two's complement negation of `-(L + 2)`. (The instruction sequence shown here to calculate the length of a text string is a well-known x86 technique.)

Before continuing it should be noted that the Visual C++ run-time environment assumes that `EFLAGS.DF` is always cleared. If an assembly language function sets `EFLAGS.DF` in order to perform an auto-decrement operation with a string instruction, the flag must be cleared before returning to the caller or using any library functions. The sample program `ReverseArray` discusses this in greater detail.

Following the computation of `len(src[i])`, a check is made to verify that the string `src[i]` will fit into the destination buffer. If the sum `des_index + len(src[i])` is greater than or equal to `des_size`, the function terminates. Otherwise, `len(src[i])` is added to `des_index` and `string src[i]` is copied to the correct position in `des` using a `rep movsw` (Repeat Move String Word) instruction.

The `rep movsw` instruction copies the string pointed to by ESI to the memory location pointed to by EDI using the length specified by ECX. An `inc ecx` instruction is executed before the string copy to ensure that the end-of-string terminator `'\0'` is also transferred to `des`. Register EDI is initialized to the correct location in `des` using a `lea edi, [ebx+edx*2]` (Load Effective Address) instruction, which computes the address of the source operand. The function can use a `lea` instruction since register EBX points to the start of `des` and EDX contains the value of `des_index` prior its addition with `len(src[i])`. Subsequent to the string copy operation, the value of `i` is updated and if it's less than `src_n`, the concatenation loop is repeated. Following completion of the concatenation operation, register EAX is loaded with `des_index`, which is the length of the final string in `des`. Output 2-13 shows the results of the sample program `ConcatStrings`.

Output 2-13. Sample Program `ConcatStrings`

Results for `ConcatStrings`

```
des_len: 18 (18) des: One Two Three Four
des_len: 15 (15) des: Red Green Blue
des_len: 24 (24) des: Airplane Car Truck Boat
```

Comparing Arrays

As mentioned in the beginning of this section, the x86 string instructions also can be used to process blocks of memory. The sample application `CompareArrays` illustrates use of the `cmps` (Compare String Operands) instruction to compare the elements of two arrays. Listings 2-34 and 2-35 contain the C++ and assembly language source code for this sample program.

Listing 2-34. CompareArrays.cpp

```

#include "stdafx.h"
#include <stdlib.h>

extern "C" int CompareArrays_(const int* x, const int* y, int n);

int _tmain(int argc, _TCHAR* argv[])
{
    const int n = 21;
    int x[n], y[n];
    int result;

    // Initialize test arrays
    srand(11);
    for (int i = 0; i < n; i++)
        x[i] = y[i] = rand() % 1000;

    printf("\nResults for CompareArrays\n");

    // Test using invalid 'n'
    result = CompareArrays_(x, y, -n);
    printf(" Test #1 - expected: %3d actual: %3d\n", -1, result);

    // Test using first element mismatch
    x[0] += 1;
    result = CompareArrays_(x, y, n);
    x[0] -= 1;
    printf(" Test #2 - expected: %3d actual: %3d\n", 0, result);

    // Test using middle element mismatch
    y[n / 2] -= 2;
    result = CompareArrays_(x, y, n);
    y[n / 2] += 2;
    printf(" Test #3 - expected: %3d actual: %3d\n", n / 2, result);

    // Test using last element mismatch
    x[n - 1] *= 3;
    result = CompareArrays_(x, y, n);
    x[n - 1] /= 3;
    printf(" Test #4 - expected: %3d actual: %3d\n", n - 1, result);

    // Test with identical elements in each array
    result = CompareArrays_(x, y, n);
    printf(" Test #5 - expected: %3d actual: %3d\n", n, result);
    return 0;
}

```

Listing 2-35. CompareArrays_.asm

```

.model flat,c
.code

; extern "C" int CompareArrays_(const int* x, const int* y, int n)
;
; Description: This function compares two integer arrays element
;             by element for equality
;
; Returns     -1          Value of 'n' is invalid
;             0 <= i < n  Index of first non-matching element
;             n           All elements match

CompareArrays_ proc
    push ebp
    mov  ebp,esp
    push esi
    push edi

; Load arguments and validate 'n'
    mov  eax,-1          ;invalid 'n' return code
    mov  esi,[ebp+8]     ;esi = 'x'
    mov  edi,[ebp+12]   ;edi = 'y'
    mov  ecx,[ebp+16]   ;ecx = 'n'
    test ecx,ecx
    jle  @F              ;jump if 'n' <= 0
    mov  eax,ecx        ;eax = 'n'

; Compare the arrays for equality
    repe cmpsd
    je  @F              ;arrays are equal

; Calculate index of unequal elements
    sub  eax,ecx
    dec  eax            ;eax = index of mismatch

@@:    pop  edi
        pop  esi
        pop  ebp
        ret

CompareArrays_ endp
end

```

The assembly language function `CompareArrays_` (Listing 2-34) compares the elements of two integer arrays and returns the index of the first non-matching element. If the arrays are identical, the number of elements is returned. Otherwise, `-1` is returned to indicate an error. The function loads `ESI` and `EDI` with pointers to arrays `x` and `y`, respectively. Register `ECX` is then loaded with the number of elements and checked for validity using a `test ecx,ecx` instruction. The `test` (Logical Compare) instruction performs a bitwise AND of the two operands and sets the status flags `EFLAGS.ZF`, `EFLAGS.SF`, and `EFLAGS.PF` based on the result (`EFLAGS.CF` and `EFLAGS.OF` are cleared). The result of the AND operation is discarded. A `test` instruction is sometimes used as an alternative to a `cmp` instruction, especially in situations where use of the former results in a smaller instruction encoding.

The arrays are compared using a `repe cmpsd` (Compare String Doubleword) instruction. This instruction compares the two doublewords pointed to by `ESI` and `EDI` and sets the status flags according to the results. Registers `ESI` and `EDI` are incremented (the value 4 is added to each register since a doubleword compare is being performed) after each compare operation. The `repe` (Repeat While Equal) prefix instructs the processor to repeat the `cmpsd` instruction as long as the condition `ECX != 0 && EFLAGS.ZF == 1` is true. Upon completion of the doubleword compare, a conditional jump is performed if the arrays are equal (`EAX` already contains the correct return value) or the index of the first non-matching elements is calculated. Output 2-14 shows the results of `CompareArrays`.

Output 2-14. Sample Program `CompareArrays`

Results for `CompareArrays`

```
Test #1 - expected: -1 actual: -1
Test #2 - expected:  0 actual:  0
Test #3 - expected: 10 actual: 10
Test #4 - expected: 20 actual: 20
Test #5 - expected: 21 actual: 21
```

Array Reversal

The final sample program of this section is called `ReverseArray` and demonstrates using the `lods` (Load String) instruction to reverse the elements of an array. Unlike the previous sample applications of this section, `ReverseArray` sweeps through the source array from the last element to the first element, which requires modification of control flag `EFLAGS.DF`. The source code files `ReverseArray.cpp` and `ReverseArray_.asm` are shown in Listings 2-36 and 2-37, respectively.

Listing 2-36. `ReverseArray.cpp`

```
#include "stdafx.h"
#include <stdlib.h>

extern "C" void ReverseArray_(int* y, const int* x, int n);
```



```

int _tmain(int argc, _TCHAR* argv[])
{
    const int n = 21;
    int x[n], y[n];

    // Initialize test array
    srand(31);
    for (int i = 0; i < n; i++)
        x[i] = rand() % 1000;

    ReverseArray_(y, x, n);

    printf("\nResults for ReverseArray\n");
    for (int i = 0; i < n; i++)
    {
        printf(" i: %5d y: %5d x: %5d\n", i, y[i], x[i]);
        if (x[i] != y[n - 1 - i])
            printf(" Compare failed!\n");
    }

    return 0;
}

```

Listing 2-37. ReverseArray_.asm

```

.model flat,c
.code

; extern "C" void ReverseArray_(int* y, const int* x, int n);
;
; Description: The following function saves the elements of array 'x'
;              to array 'y' in reverse order.
;
; Returns      0 = Invalid 'n'
;              1 = Success

ReverseArray_ proc
    push ebp
    mov ebp,esp
    push esi
    push edi

; Load arguments, make sure 'n' is valid
    xor eax,eax ;error return code
    mov edi,[ebp+8] ;edi = 'y'
    mov esi,[ebp+12] ;esi = 'x'
    mov ecx,[ebp+16] ;ecx = 'n'
    test ecx,ecx
    jle Error ;jump if 'n' <= 0

```

```

; Initialize pointer to x[n - 1] and direction flag
    lea esi,[esi+ecx*4-4]           ;esi = &x[n - 1]
    pushfd                         ;save current direction flag
    std                             ;EFLAGS.DF = 1

; Repeat loop until array reversal is complete
@@:  lodsd                         ;eax = *x--
     mov [edi],eax                 ;*y = eax
     add edi,4                     ;y++
     dec ecx                       ;n--
     jnz @B

     popfd                         ;restore direction flag
     mov eax,1                     ;set success return code

Error: pop edi
       pop esi
       pop ebp
       ret
ReverseArray_ endp
end

```

The function `ReverseArray_` (Listing 2-36) copies the elements of a source array to a destination array in reverse order. The function requires three parameters: a pointer to a destination array named `y`, a pointer to a source array named `x`, and the number of elements `n`. The argument values of parameters are loaded into registers `EDI`, `ESI`, and `ECX`, respectively.

In order to reverse the elements of the source array, the address of the last array element `x[n - 1]` needs to be calculated. This is accomplished using a `lea esi,[esi+ecx*4-4]` instruction, which computes the effective address of the source memory operand (i.e. it performs the arithmetic specified between the brackets). The current state of `EFLAGS.DF` is saved on the stack using a `pushfd` (Push `EFLAGS` Register onto the Stack), followed by a `std` (Set Direction Flag) instruction. The duplication of array elements from `x` to `y` is straightforward. A `lodsd` (Load String Doubleword) instruction loads an element from `x` into `EAX` and decrements register `ESI`. This value is saved to the element in `y` that is pointed to by `EDI`. An `add edi,4` instruction points `EDI` to the next element in `y`. Register `ECX` is then decremented and the loop is repeated until the array reversal is complete.

Following the reverse array loop, a `popfd` (Pop Stack into `EFLAGS` Register) is used to restore the original state of `EFLAGS.DF`. One question that might be asked at this point is if the Visual C++ run-time environment assumes that `EFLAGS.DF` is always cleared, why doesn't the function `ReverseArray_` use a `cld` (Clear Direction Flag) instruction to restore `EFLAGS.DF` instead of a `pushfd/popfd` sequence? Yes, the Visual C++ run-time environment *assumes* that `EFLAGS.DF` is always cleared, but it cannot enforce this policy during program execution. Since `ReverseArray_` is declared as a public function, it could be called by another assembly language function that violates the `EFLAGS.DF` state rules. If `ReverseArray_` were to be included in a DLL, it could conceivably be called by a

function written in a language that uses a different convention for the direction flag. Using `pushfd` and `popfd` ensures that the state of the caller's direction is always properly restored. The results of the sample program `ReverseArray` are shown in Output 2-15.

Output 2-15. Sample Program `ReverseArray`

```
Results for ReverseArray
i:    0 y:  409 x:   139
i:    1 y:   48 x:   240
i:    2 y:  981 x:   971
i:    3 y:  643 x:   503
i:    4 y:  102 x:   927
i:    5 y:  114 x:   453
i:    6 y:  366 x:   547
i:    7 y:  697 x:    76
i:    8 y:   87 x:   789
i:    9 y:  466 x:   862
i:   10 y:  268 x:   268
i:   11 y:  862 x:   466
i:   12 y:  789 x:    87
i:   13 y:   76 x:   697
i:   14 y:  547 x:   366
i:   15 y:  453 x:   114
i:   16 y:  927 x:   102
i:   17 y:  503 x:   643
i:   18 y:  971 x:   981
i:   19 y:  240 x:    48
i:   20 y:  139 x:   409
```

Summary

This chapter examined a significant amount of material related to x86 assembly language programming. This includes the rudiments of an x86 assembly language function; essential topics such as calling conventions, integer arithmetic, memory addressing modes, and condition codes; and how to use x86 assembly language with common programming constructs such as arrays, structures, and text strings.

If this is your first venture into the world of assembly language programming and you're feeling a little overwhelmed at this point, don't worry. It has been my experience that the best way to become comfortable with a new programming language is to start by coding simple programs and then gradually work toward learning the more sophisticated aspects of the language. The sample code that's included with this book is structured to achieve this goal. All of the assembly language functions are relatively short and contain minimal dependencies in order to facilitate "hands-on" learning and experimentation. Simple console programs are also used in order to avoid excessive complexity.

Chapters 1 and 2 explained key elements of the x86-32 platform and its execution environment. You'll use this knowledge as you explore other facets of the x86 platform, including the x87 floating-point unit, which is the topic of Chapters 3 and 4.



X87 Floating-Point Unit

The x86 platform includes a discrete execution unit that is capable of performing floating-point arithmetic. This unit, known as the x87 floating-point unit (FPU), employs dedicated hardware to implement fundamental floating-point operations such as addition, subtraction, multiplication and division. It is also equipped to carry out more sophisticated computations using built-in square root, trigonometric, and logarithmic instructions. The x87 FPU supports a variety of numerical data types, including single and double precision floating-point, signed integers, and packed BCD.

This chapter examines the architecture of the x87 FPU. You'll learn about the x87 FPU's major components, including its data registers, control register, and status register. You'll also study the binary encoding formats that the x87 FPU uses to represent floating-point numbers and certain special values. Software developers who understand these encoding schemes can frequently use this knowledge to minimize potential floating-point errors or improve the performance of algorithms that make heavy use of floating-point values. The chapter concludes with an overview of the x87 FPU instruction set.

X87 FPU Core Architecture

Architecturally, the x87 FPU includes eight 80-bit wide data registers and a set of special-purpose registers. The special-purpose register set contains a control register and a status register that the programmer can use to configure the x87 FPU and determine its current status. The special-purpose register set also includes several auxiliary registers that are used primarily by operating systems and floating-point exception handlers. Figure 3-1 illustrates the major components of the x87 FPU.



Figure 3-1. X87 FPU core architecture

Data Registers

The x87 FPU's eight data registers are organized as a stack. All arithmetic instructions are executed using either implicit or explicit operands relative to the stack top. Different data types can be pushed onto or popped off the x87 FPU register stack, including signed integers (16, 32, and 64 bits), floating-point values (32, 64, and 80 bits), and 80-bit packed BCD quantities. Data transfers between an x87 FPU data register and an x86-32 general-purpose register are not possible; an intermediate memory location must be used to perform this type of operation. However, it should be noted that these types of data transfers are not performed that often. Except for an exceedingly small set of commonly used values, arithmetic constants also must be loaded onto the x87 FPU register stack using a memory operand since the x87 FPU instruction set does not support immediate operands.

All of the x87 FPU's numerical formats, processing algorithms, and exception signaling procedures are based on an IEEE standard for binary floating-point arithmetic (IEEE 754-1985). Internally, the x87 FPU maintains numerical values using an 80-bit double extended-precision format. Conversion between this internal format and all supported integer, floating-point, and BCD formats occurs automatically during x87 FPU register load and store operations.

X87 FPU Special-Purpose Registers

The x87 FPU contains several special-purpose registers, which are used to configure the FPU, determine its status, and facilitate exception processing. The x87 FPU control register, shown in Figure 3-2, allows a task to enable or disable various floating-point processing options, including exceptions, rounding method, and precision level. Unlike most other x86 control registers, modification of the x87 FPU control register does not require elevated run-time privileges; application programs can configure the x87 FPU based on an algorithm's specific processing requirements. Table 3-1 describes the meaning of each field in the x87 FPU control register.

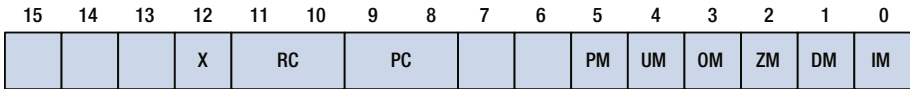

Figure 3-2. X87 FPU control register

Table 3-1. X87 FPU Control Register Fields

Bit	Field Name	Description
IM	Invalid operation mask	Invalid operation exception mask bit; 1 disables the exception.
DM	Denormal operand mask	Denormal operand exception mask bit; 1 disables the exception.
ZM	Zero divide mask	Division-by-zero exception mask bit; 1 disables the exception.
OM	Overflow mask	Overflow exception mask bit; 1 disables the exception.
UM	Underflow mask	Underflow exception mask bit; 1 disables the exception.
PM	Precision mask	Precision exception mask bit; 1 disables the exception.
PC	Precision control field	Specifies the precision for basic floating-point calculations. Valid options include single precision (00b), double precision (10b), and double extended precision (11b).
RC	Rounding control field	Specifies the method for rounding x87 FPU results. Valid options include round to nearest (00b), round down towards $-\infty$ (01b), round up towards $+\infty$ (10b), and round towards zero or truncate (11b).
X	Infinity control bit	Enables processing of infinity values in a manner that is compatible with the 80287 math coprocessor. Modern software can ignore this flag.

Setting an exception mask bit to 1 in the x87 FPU control register disables only the generation of a processor exception. The x87 FPU status register always records the occurrence of any x87 FPU exception condition. Application programs cannot directly access the internal processor table that specifies the x87 FPU exception handler. Most C and C++ compilers, however, provide a library function that allows an application program to designate a callback function that gets invoked whenever an x87 FPU exception occurs.

The x87 FPU status register contains a 16-bit value that allows a task to determine the results of an arithmetic operation, check if an exception has occurred, or query stack status information. Figure 3-3 shows the organization of the fields in the x87 FPU status register and Table 3-2 describes the meaning of each status register field.

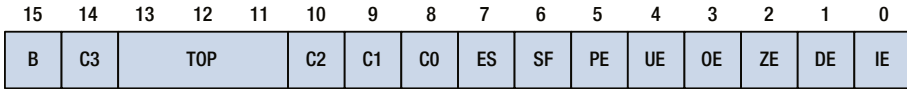

Figure 3-3. X87 FPU status register

Table 3-2. X87 FPU Status Register Fields

Bit	Field Name	Description
IE	Invalid operation exception	Invalid operation exception status; set to 1 whenever an instruction uses an invalid operand.
DE	Denormal operand exception	Denormal operand exception status; set to 1 whenever an instruction uses a denormal operand.
ZE	Zero divide exception	Division-by-zero exception status; set to 1 whenever an instruction attempts division-by-zero.
OE	Overflow exception	Overflow exception status; set to 1 if a result exceeds the maximum allowable value for destination operand.
UE	Underflow exception	Underflow exception status; set to 1 if a result is smaller than the minimum allowable value for destination operand.
PE	Precision exception	Precision exception status; set to 1 if a result cannot be exactly represented using binary format of destination operand.
SF	Stack fault	Signifies that a stack fault has occurred when set to 1 (the Invalid Operation exception flag is also set to 1); condition code bit C1 indicates the stack fault type: underflow (C1 = 0) or overflow (C1 = 1).
ES	Error summary status	Indicates that at least one unmasked exception bit is set.
C0	Condition code flag 0	X87 FPU status flag (see text).

(continued)

Table 3-2. (continued)

Bit	Field Name	Description
C1	Condition code flag 1	X87 FPU status flag (see text).
C2	Condition code flag 2	X87 FPU status flag (see text).
TOS	Top-of-stack register	Three-bit value that indicates the current top-of-stack register.
C3	Condition code flag 3	X87 FPU status flag (see text).
B	Busy flag	Duplicates the state of the ES flag; provided for 8087 compatibility; modern application programs can ignore this flag.

The exception flags in the x87 FPU status register are set whenever a floating-point error condition occurs following the execution of an x87 FPU instruction. These flags are not automatically cleared by the processor; they must manually reset using an `fclex` or `fnclex` (Clear Exceptions) instruction. The condition code flags report the results of floating-point arithmetic and compare operations. They are also used by some instructions to indicate errors or additional status information. The bits of the x87 FPU status register (also called the x87 FPU status word) cannot be directly tested. They must be copied to memory or register AX using an `fstsw` or `fnstsw` (Store x87 FPU Status Word) instruction.

The x87 FPU also contains a 16-bit tag word register, which denotes the contents of each 80-bit data register. The tag word can be examined either by an application program or exception handler. Possible floating-point register tags states include valid (00b), zero (01b), special (10b), or empty (11b). The special tag state includes invalid format, denormal, or infinity. The meanings of these states are described later in this chapter.

Finally, the x87 FPU includes three registers that are used primarily by operating systems and exception handlers. The last instruction pointer, last data pointer, and last instruction opcode registers allow an exception handler to ascertain additional information about the specific instruction that caused an exception. The sizes of the last instruction pointer and last data pointer registers vary depending on whether the current processor execution mode is x86-32 or x86-64. The size of the last instruction opcode register is 11 bits. This register contains the low-order opcode bits of the last non-control x87 FPU instruction that was executed (the upper five bits of an x87 FPU instruction opcode are not saved since these bits are always 11011b).

X87 FPU Operands and Encodings

The x87 FPU instruction set supports three types of memory operands: signed integer, floating-point, and packed BCD. Usable signed-integer operands include word (16 bits), doubleword (32 bits), and quadword (64 bits). Supported floating-point operands include single precision (32 bits), double precision (64 bits), and double extended-precision (80 bits). Many C and C++ compilers use the single-precision and double-precision operand types to implement `float` and `double` values, respectively. The sole packed BCD format

is 80 bits in length. X87 FPU instructions may use any of the addressing modes that were described in Chapter 1 to specify an operand in memory. Figure 3-4 illustrates the organization of all valid x87 memory operand types.

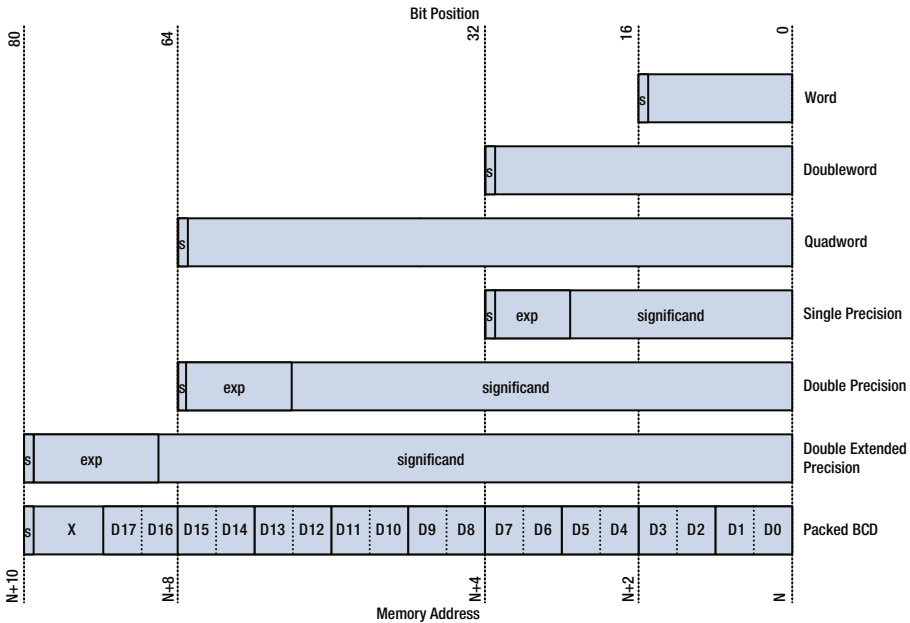

Figure 3-4. X87 memory operand types

The x87 FPU encodes a floating-point value using three distinct fields: a significand, an exponent, and a sign bit. The significand field represents a number’s significant digits (or fractional part). The exponent specifies the location of the binary “decimal” point in the significand, which determines the magnitude. The sign bit indicates whether the number is positive ($s = 0$) or negative ($s = 1$). Table 3-3 lists the various size parameters that are used to encode single, double, and double-extended precision floating-point values.

Table 3-3. Floating-Point Size Parameters

Parameter	Single	Double	Double-Extended
Total width	32	64	80
Significand width	23	52	63
Exponent width	8	11	15
Sign width	1	1	1
Exponent bias	+127	+1023	+16383

Figure 3-5 illustrates the process that is used to convert a decimal number into an x87-FPU compatible floating-point encoded value. In this example, the number 237.8325 is transformed from a decimal number to its single-precision floating-point encoding. The process starts by converting the number from base 10 to base 2. Next, the base 2 value is transformed to a binary scientific value. The value to the right of the E_2 symbol is the binary exponent. A properly encoded floating-point value uses a biased exponent instead of the true exponent since this expedites floating-point compare operations. For a single-precision floating-point number, the bias value is +127. Adding the exponent bias value to the true exponent creates a binary scientific with biased exponent value. In the example that's shown in Figure 3-5, adding 111b to 1111111b (+127) yields a binary scientific with a biased exponent value of 10000110b.

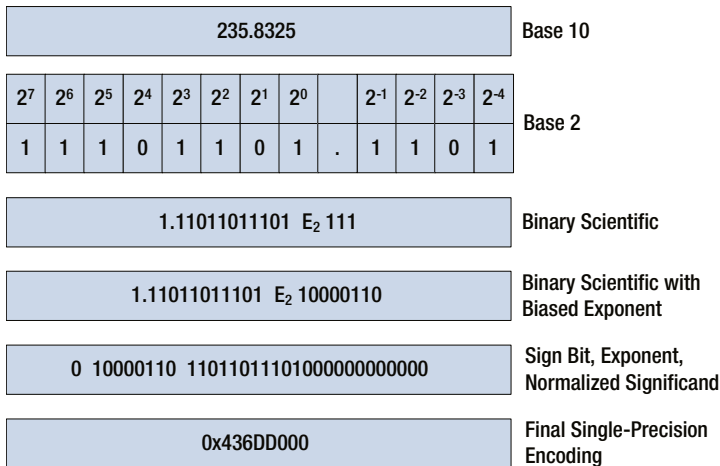

Figure 3-5. Single-precision floating-point encoding process

When encoding a single-precision or double-precision floating-point value, the leading 1 digit of the significand is implied and not included in the final binary representation. The leading 1 digit is included when encoding a number using double extended-precision format. Dropping the leading 1 digit forms a normalized significand. The three fields required for an IEEE 754 compliant encoding are now available, as shown in Table 3-4. A reading of the bit fields in Table 3-4 from left to right yields the 32-bit value 0x436DD000, which is the final single-precision floating-point encoding of 237.8325.

Table 3-4. IEEE 754-Compliant Fields

Sign	Biased Exponent	Normalized Significand
0	10000110	1101101110100000000000

The x87 FPU encoding scheme also reserves a small set of bit patterns for special values that are used to handle certain processing conditions. The first group of special values includes denormalized numbers (also called a denormal). As shown in the earlier encoding example, the standard encoding of a floating-point number assumes that the leading digit of the significand is always a 1. One drawback of x87 FPU's floating-point encoding scheme is its inability to accurately represent numbers very close to zero. In these cases, the x87 FPU will encode such numbers using a non-normalized format, which enables tiny numbers close to zero (both positive and negative) to be encoded using less precision. Denormals rarely occur but when they do, the x87 FPU can still process them. In algorithms where the use of a denormal is problematic, a function can test a floating-point value in order to ascertain its denormal state or the x87 FPU can be configured to generate either an underflow or denormal exception.

Another application of special values involves the encodings that are used for floating-point zero. The x87 FPU supports two different representations of floating-point zero: positive zero (+0.0) and negative zero (-0.0). A negative zero can be generated either algorithmically or as a side effect of the x87 FPU's rounding mode. Computationally, the x87 FPU treats positive and negative zero the same and the programmer typically does not need to be concerned. However, the x87 FPU includes instructions that can be used to test the sign bit of a floating-point value.

The x87 FPU encoding scheme also supports positive and negative representations of infinity. Infinities are produced by certain numerical algorithms, overflow conditions, or division by zero. As discussed earlier in this chapter, the x87 FPU can be configured to generate an exception whenever an overflow occurs or a program attempts to divide a number by zero.

The final special value type is called Not a Number (NaN). NaNs are simply floating-point encodings that are not valid numbers. The x87 FPU defines two types of NaNs: signaling NaN (SNaN) and quiet NaN (QNaN). SNaNs are created by software; the FPU will not create a SNaN during any arithmetic operation. Any attempt by an instruction to use a SNaN will cause an invalid operation exception, unless the exception is masked. SNaNs are useful for testing exception handlers. They also can be exploited by an application program for proprietary numerical-processing purposes. The x87 FPU uses QNaNs as a default response to certain invalid arithmetic operations whose exceptions are masked. For example, one unique encoding of a QNaN, called an indefinite, is substituted for a result whenever a function uses the `fsqrt` (Square Root) instruction with a negative value. QNaNs also can be used by programs to signify algorithm-specific errors or other unusual numerical conditions. When QNaNs are used as operands, they enable continued processing without generating an exception.

When developing software for the x87 FPU or any other floating-point platform, it is important to keep in mind that the employed encoding scheme is simply an approximation of a real-number system. It is impossible for any floating-point encoding system to represent an infinite number of values using a finite number of bits. This leads to floating-point rounding errors that can affect the accuracy of a calculation. Also, some mathematical properties that hold true for integers and real numbers are not necessarily true for floating-point numbers. For example, floating-point multiplication is not necessarily associative; $(a * b) * c$ may not equal $a * (b * c)$ depending on the values of a , b , and c . Developers of algorithms that require high levels of floating-point accuracy must be aware of these issues.

X87 FPU Instruction Set

The following section presents a brief overview of the x87 FPU instruction set. Similar to the x86-32 instruction set review in Chapter 1, the purpose of this section is to provide you with a general understanding of the x87 FPU instruction set. Additional information regarding each x87 FPU instruction including valid operands, affected condition codes, and the effects of control word options is available in the reference manuals published by AMD and Intel. A list of these manuals and other x87 FPU documentation resources is included in Appendix C. The sample code of Chapter 4 also contains more information regarding x87 FPU instruction set use.

The x87 FPU instruction set can be partitioned into the following six functional groups:

- Data transfer
- Basic arithmetic
- Data comparison
- Transcendental
- Constants
- Control

In the instruction descriptions that follow, $ST(0)$ denotes the top-most value on the x87 FPU register stack, while $ST(i)$ denotes the i -th register from the current stack top. Most x87 FPU calculating instructions use $ST(0)$ as an implicit operand while $ST(i)$ must be explicitly specified.

Data Transfer

The data transfer group contains instructions that push values onto or pop values from the x87 FPU register stack. The x87 FPU uses different instruction mnemonics to perform push (load) and pop (store) operations depending on whether the operand data type is a floating-point, integer, or packed BCD value. Table 3-5 summarizes the data-transfer instructions.

Table 3-5. X87 FPU Data-Transfer Instructions

Mnemonic	Description
fld	Pushes a floating-point value onto the register stack. The source operand can be the contents of $ST(i)$ or a memory location.
flid	Reads a signed integer operand from memory, converts the value to a double extended-precision value, and pushes this result onto the register stack.
fbld	Reads a packed-BCD operand from memory, converts the value to a double extended-precision value, and pushes this result onto the stack.
fst	Copies $ST(0)$ to $ST(i)$ or a memory location.

(continued)

Table 3-5. (continued)

Mnemonic	Description
<code>fstp</code>	Performs the same operation as the <code>fst</code> instruction and pops the stack.
<code>fist</code>	Converts the value in <code>ST(0)</code> to an integer and saves the result to the specified memory location.
<code>fistp</code>	Performs the same operation as the <code>fist</code> instruction and pops the stack.
<code>fisttp</code>	Converts the value in <code>ST(0)</code> to an integer using truncation, saves the result to the specified memory location, and pops the stack. This instruction is available on processors that support SSE3.
<code>fbstp</code>	Converts the value in <code>ST(0)</code> to packed BCD format, saves the result to the specified memory location, and pops the stack.
<code>fxch</code>	Exchanges the contents of registers <code>ST(0)</code> and <code>ST(i)</code> .
<code>fcmovcc</code>	Conditionally copies the contents of <code>ST(i)</code> to <code>ST(0)</code> if the specified condition is true. Valid condition codes are outlined in Table 3-6. A floating-point compare instruction is generally used before an <code>fcmovcc</code> instruction. See the “Data Comparison” section for more information about floating-point compares.

Table 3-6. Condition Codes for `fcmovcc` Instruction

Condition Code	Description	Test Condition
B	Below	<code>CF == 1</code>
NB	Not below	<code>CF == 0</code>
E	Equal	<code>ZF == 1</code>
NE	Not equal	<code>ZF == 0</code>
BE	Below or equal	<code>CF == 1 ZF == 1</code>
NBE	Not below or equal	<code>CF == 0 && ZF == 0</code>
U	Unordered	<code>PF == 1</code>
NU	Not unordered (i.e. ordered)	<code>PF == 0</code>

The “Data Comparison” section contains additional details regarding the use of ordered and unordered floating-point compares.

Basic Arithmetic

The basic arithmetic group contains instructions that perform standard arithmetic operations including addition, subtraction, multiplication, division, and square roots. These instructions are summarized in Table 3-7.

Table 3-7. X87 FPU Basic Arithmetic Instructions

Mnemonic	Description
<code>fadd</code>	Adds the source and destination operands. The source operand can be a memory location or an x87 FPU register. The destination operand must be an x87 FPU register.
<code>faddp</code>	Adds ST(i) and ST(0), saves sum to ST(i), and pops the stack.
<code>fiadd</code>	Adds ST(0) and the specified integer operand and saves the sum to ST(0).
<code>fsub</code>	Subtracts the source operand (subtrahend) from destination operand (minuend) and saves the result in the destination operand. The source operand can be a memory location or an x87 FPU register. The destination operand must be an x87 FPU register.
<code>fsubr</code>	Subtracts the destination operand (subtrahend) from the source operand (minuend) and saves the result in the destination operand. The source operand can be a memory location or an x87 FPU register. The destination operand must be an x87 FPU register.
<code>fsubp</code>	Subtracts ST(0) from ST(i), saves the difference to ST(i), and pops the stack.
<code>fsubrp</code>	Subtracts ST(i) from ST(0), saves the difference to ST(i), and pops the stack.
<code>fisub</code>	Subtracts the specified integer operand from ST(0) and saves the difference to ST(0).
<code>fisubr</code>	Subtracts ST(0) from the specified integer operand and saves the difference to ST(0).
<code>fmul</code>	Multiplies the source and destination operands and saves the product in the destination operand. The source operand can be a memory location or an x87 FPU register. The destination operand must be an x87 FPU register.
<code>fmulp</code>	Multiplies ST(i) and ST(0), saves the product to ST(i), and pops the stack.
<code>fimul</code>	Multiplies ST(0) and the specified integer operand and then saves the product to ST(0).
<code>fdiv</code>	Divides the destination operand (dividend) by the source operand (divisor). The source operand can be a memory location or an FPU register. The destination operand must be an x87 FPU register.
<code>fdivr</code>	Divides the source operand (dividend) by the destination operand (divisor). The source operand can be a memory location or an FPU register. The destination operand must be an x87 FPU register.
<code>fdivp</code>	Divides ST(i) by ST(0), saves the quotient to ST(i), and pops the stack.
<code>fdivrp</code>	Divides ST(0) by ST(i), saves the quotient to ST(i), and pops the stack.

(continued)

Table 3-7. (continued)

Mnemonic	Description
<code>fidiv</code>	Divides ST(0) by the specified integer operand and then saves the quotient to ST(0).
<code>fidivr</code>	Divides the specified integer operand by ST(0) and then saves the quotient to ST(0).
<code>fprem</code>	Calculates a partial remainder of ST(0) divided by ST(1) and then saves the result to ST(0). This instruction is typically used in a loop to calculate the true remainder.
<code>fprem1</code>	Similar to the <code>fprem</code> instruction except that the partial remainder is calculated using the algorithm specified by the IEEE 754 standard.
<code>fabs</code>	Calculates the absolute value of ST(0) and saves the result to ST(0).
<code>fchs</code>	Complements the sign bit of ST(0) and saves the result to ST(0).
<code>frndint</code>	Rounds the value in ST(0) to the nearest integer and then saves the result to ST(0). The RC field of the x87 FPU control word specifies the rounding method that is used.
<code>fsqrt</code>	Calculates the square root of ST(0) and then saves the result to ST(0).
<code>fextract</code>	Separates ST(0) into its exponent and significand components. Following execution of this instruction, ST(0) contains the significand and ST(1) contains the exponent.

Data Comparison

The data-comparison group contains instructions that are used to compare and test floating-point values. As discussed earlier in this chapter, the x87 FPU status word contains a set of condition code flags that are used to indicate the results of arithmetic and compare instructions. Table 3-8 shows the state of the condition code flags following execution of a floating-point compare or test instruction (e.g. `fcom`, `fucom`, `ficom`, `ftst`, or `fxam`, and the “pop” versions of these instructions where applicable). Table 3-9 summarizes the x87 FPU data compare instructions.

Table 3-8. Condition Code Flags for x87 FPU Compare Instructions

Condition	C3	C2	C0
ST(0) > SRC_OP	0	0	0
ST(0) < SRC_OP	0	0	1
ST(0) == SRC_OP	1	0	0
Unordered	1	1	1

Table 3-9. X87 FPU Data Compare Instructions

Mnemonic	Description
<code>fcom</code>	Compares ST(0) with ST(i) or an operand in memory and sets the x87 FPU condition code flags based on the result.
<code>fcomp</code> <code>fcompp</code>	Compares ST(0) with ST(i) or an operand in memory, sets the x87 FPU condition code flags, and pops the stack. The <code>fcompp</code> instruction pops the stack twice.
<code>fucom</code>	Performs an unordered compare of ST(0) and ST(i) and sets the x87 FPU condition code flags based on the result.
<code>fucomp</code> <code>fucompp</code>	Performs an unordered compare of ST(0) and ST(i), sets the x87 FPU condition code flags, and pops the stack. The <code>fucompp</code> pops the stack twice.
<code>ficom</code>	Compares ST(0) with a memory-based integer operand and sets the x87 FPU condition code flags based on the result.
<code>ficomp</code>	Compares ST(0) with a memory-based integer operand, sets the x87 FPU condition code flags, and pops the stack.
<code>fcomi</code>	Compares ST(0) with ST(i) and directly sets EFLAGS.CF, EFLAGS.PF, and EFLAGS.ZF based on the result.
<code>fcomip</code>	Performs the same operation as <code>fcomi</code> and pops the stack.
<code>fucomi</code>	Performs an unordered compare of ST(0) and ST(i) and directly sets EFLAGS.CF, EFLAGS.PF, and EFLAGS.ZF based on the result.
<code>fucomip</code>	Performs the same operation as <code>fucomi</code> and pops the stack.
<code>fstst</code>	Compares ST(0) with 0.0 and sets the x87 FPU condition code flags based on the result.
<code>fxam</code>	Examines ST(0) and sets the x87 FPU condition code flags, which signifies the class of the value. Possible classes include denormal number, empty, infinity, NaN, normal finite number, unsupported, and zero.

There are no x86 or x87 FPU conditional jump instructions that directly test the condition code flags. In order to make a program control-flow jump decision based on the state of the condition code flags, the flags must be transferred to the processor's EFLAGS register. This is accomplished using the instruction sequences `fstsw ax` (Store x87 FPU status word in AX) and `sahf` (Store AH into flags), which copy the condition code flags C0, C2, and C3 to EFLAGS.CF, EFLAGS.PF, and EFLAGS.ZF, respectively. Processors based on a P6 or later microarchitecture (which includes all processors marketed since 1997) also can use the `fcomi` and `fucomi` instructions to directly set EFLAGS.CF, EFLAGS.PF, and EFLAGS.ZF. Following setting of EFLAGS status bits, a conditional jump can be performed using the condition codes described in Table 3-6.

Unlike an integer compare, there are four possible and mutually exclusive outcomes of a floating-point compare: less than, equal, greater than, and unordered. An unordered floating-point compare occurs when at least one of the operands is a NaN or invalid floating-point value. In an ordered compare, both operands are valid floating-point numbers. Using an x87 FPU ordered compare instruction with a NaN or invalid value will cause the processor to generate an invalid operation exception. If the invalid operation exception is masked, the x87 FPU condition code flags or EFLAGS status bits are set accordingly. An unordered compare instruction will generate an x87 FPU invalid operation exception if one of the operands is a SNaN or invalid. The x87 FPU condition code flags or EFLAGS status bits are set if the invalid operation exception is masked. The use of a QNaN operand during execution of an unordered compare instruction causes the condition code flags or EFLAGS status bits to be set accordingly, but an exception is never generated.

Transcendental

The transcendental group contains instructions that perform trigonometric, logarithmic, and exponential operations on floating-point operands. Table 3-10 lists the transcendental group instructions.

Table 3-10. X87 FPU Transcendental Instructions

Mnemonic	Description
fsin	Calculates the sine of ST(0) and saves the result to ST(0).
fcos	Calculates the cosine of ST(0) and saves the result to ST(0).
fsincos	Calculates the sin and cosine of ST(0). Following execution of this instruction, ST(0) and ST(1) contain the cosine and sine, respectively, of the original operand.
fptan	Computes the tangent of ST(0), saves the result to ST(0), and pushes the constant 1.0 onto the stack.
fpatan	Computes the arctangent of ST(1) divided by ST(0) and saves the result to ST(0).
f2xm1	Computes $2^{(ST(0) - 1)}$ and saves the result in ST(0). The value of the source operand must reside between -1.0 and +1.0.
fy12x	Computes $ST(1) * \log_2(ST(0))$, saves the result in ST(1), and pops the stack.
fy12xp1	Computes $ST(1) * \log_2(ST(0) + 1.0)$, saves the result in ST(1), and pops the stack.
fscale	Truncates the value in ST(1) and adds this value to the exponent of ST(0). This instruction is used to perform fast multiplication and division by an integral power-of-two.

Constants

The constants group contains instructions that are used to load commonly-used floating-point constant values. Table 3-11 lists the constants group instructions.

Table 3-11. X87 FPU Constants Instructions

Mnemonic	Description
fld1	Pushes the constant +1.0 onto the x87 FPU register stack.
fldz	Pushes the constant +0.0 onto the x87 FPU stack.
fldpi	Pushes the constant π onto the x87 FPU stack.
fldl2e	Pushes the constant value $\log_2(e)$ onto the x87 FPU stack.
fldln2	Pushes the constant value $\ln(2)$ onto the x87 FPU stack
fldl2t	Pushes the constant $\log_2(10)$ onto the x87 FPU stack.
fldlg2	Pushes the constant $\log_{10}(2)$ onto the x87 FPU stack.

Control

The control group contains instructions that are used to manage the x87 FPU control register and status register. It also includes instructions that facilitate administration of the x87 FPU's execution environment and running state. Table 3-12 outlines the control group instructions. An instruction whose mnemonic begins with the prefix *fn* will ignore all pending unmasked floating-point exceptions prior to its execution. The standard prefix version services any pending unmasked floating-point exceptions prior to performing the required operation.

Table 3-12. X87 FPU Control Instructions

Mnemonic	Description
finit fninit	Initializes the x87 FPU to its default state.
fincstp	Changes the current stack pointer position by adding one to the TOS field in the x87 FPU status word. The contents of the x87 FPU's data registers and tag word are not modified, which means that this instruction is not equivalent to a stack pop. This instruction can be used to manually manage the x87 FPU register stack.
fdecstp	Changes the current stack pointer position by subtracting one from the TOS field in the x87 FPU status word. The contents of the x87 FPU's data registers and tag word are not modified, which means that this instruction is not equivalent to a stack push. This instruction can be used to manually manage the x87 FPU register stack.

(continued)

Table 3-12. (continued)

Mnemonic	Description
ffree	Frees an x87 FPU floating-point register by setting its tag word state to empty.
fldcw	Loads the x87 FPU control word from the specified memory location.
fstcw fnstcw	Stores the x87 FPU control word to the specified memory location.
fstsw fnstsw	Stores the x87 FPU status word to the AX register or a memory location.
fclex fnclex	Clears the following x87 FPU status word bits: PE, UE, OE, ZE, DE, IE, ES, SE, and B. The state of condition code flags C0, C1, C2, and C3 are undefined following execution of this instruction.
fstenv fnstenv	Saves the current x87 FPU execution environment to memory, which includes the control word, status word, tag word, x87 FPU data pointer, x87 FPU instruction pointer, and x87 FPU last instruction opcode.
fldenv	Loads an x87 FPU execution environment from memory.
fsave fnsave	Saves the current x87 FPU operating state, which includes the contents of all data registers and following items: control word, status word, tag word, x87 FPU data pointer, x87 FPU instruction pointer, and x87 FPU last instruction opcode.
frstor	Loads an x87 FPU operating state from memory.

Summary

This chapter covered the core architecture of the x87 FPU including its data types, stack-oriented register set, control register, and status register. You also learned a little about the binary encodings that are used to represent floating-point values. If this is your first encounter with a floating-point architecture, some of the presented material might seem a little abstruse. The content of Chapter 4, which contains a number of sample programs that illustrate how to perform floating-point calculations using the x87 FPU instruction set, should help clarify any lingering abstruseness.

CHAPTER 4



X87 FPU Programming

This chapter covers additional details about the architecture of the x87 FPU and its instruction set. The chapter includes an assortment of x86 assembly language functions that demonstrate the fundamentals of x87 FPU programming along with some advanced techniques. You'll begin your exploration of the x87 FPU with an examination of some sample programs that illustrate how to perform basic arithmetic and compare operations using floating-point numbers. Next, you'll learn how to perform calculations using floating-point arrays. The final set of sample programs in this chapter describes the x87 FPU's transcendental instructions along with a few techniques that exemplify efficient x87 FPU register stack use. The content of this chapter assumes that you're familiar with material presented in Chapters 1, 2, and 3.

■ **Note** Development of software that employs floating-point arithmetic always entails a few caveats. The purpose of the sample programs presented in this chapter is to elucidate the architecture and instruction set of the x87 FPU. The sample programs do not address important floating-point concerns such as rounding errors, numerical stability, or ill-conditioned functions. Software developers must always be cognizant of these issues during the design and implementation of any algorithm that employs floating-point arithmetic. If you're interested in learning more about the potential pitfalls of floating-point arithmetic, consult the references listed in Appendix C.

X87 FPU Programming Fundamentals

This section examines a couple of sample programs that illustrate the fundamentals of x87 FPU programming. The first sample program demonstrates using the x87 FPU to perform simple arithmetic. It also shows you how to declare and reference integer and floating-point constants in memory. The second sample program explains how to perform compare operations using floating-point values. You'll also learn how to carry out conditional jumps using the results of a compare operation.

Simple Arithmetic

The first sample program that you'll look at is called `TemperatureConversions`. This sample program contains a couple of functions that convert a temperature value from Fahrenheit to Celsius and vice versa using the x87 FPU. Despite their triviality, these temperature-conversion functions demonstrate a number of essential x87 FPU programming concepts including utilization of x87 FPU register stack and treatment of floating-point constants in memory. They also illustrate how an assembly language function can return a floating-point value back to its caller. Listings 4-1 and 4-2 contain the C++ and assembly language source code files for this sample program.

Listing 4-1. `TemperatureConversions.cpp`

```
#include "stdafx.h"

extern "C" double FtoC(double deg_f);
extern "C" double CtoF(double deg_c);

int _tmain(int argc, _TCHAR* argv[])
{
    double deg_fvals[] = {-459.67, -40.0, 0.0, 32.0, 72.0, 98.6, 212.0};
    int nf = sizeof(deg_fvals) / sizeof(double);

    for (int i = 0; i < nf; i++)
    {
        double deg_c = FtoC(deg_fvals[i]);
        printf("i: %d  f: %10.4lf  c: %10.4lf\n", i, deg_fvals[i], deg_c);
    }

    printf("\n");

    double deg_cvals[] = {-273.15, -40.0, -17.77, 0.0, 25.0, 37.0, 100.0};
    int nc = sizeof(deg_cvals) / sizeof(double);

    for (int i = 0; i < nc; i++)
    {
        double deg_f = CtoF(deg_cvals[i]);
        printf("i: %d  c: %10.4lf  f: %10.4lf\n", i, deg_cvals[i], deg_f);
    }

    return 0;
}
```

Listing 4-2. TemperatureConversions_.asm

```

        .model flat,c
        .const

r8_SfFtoC  real8 0.5555555556          ; 5 / 9
r8_SfCtoF  real8 1.8                  ; 9 / 5
i4_32      dword 32

; extern "C" double FtoC_(double f)
;
; Description:  Converts a temperature from Fahrenheit to Celsius.
;
; Returns:     Temperature in Celsius.

        .code
FtoC_   proc
        push ebp
        mov ebp,esp

        fld [r8_SfFtoC]                ;load 5/9
        fld real8 ptr [ebp+8]          ;load 'f'
        fiild [i4_32]                 ;load 32
        fsubp                          ;ST(0) = f - 32
        fmulp                          ;ST(0) = (f - 32) * 5/9

        pop ebp
        ret
FtoC_   endp

; extern "C" double CtoF_(double c)
;
; Description:  Converts a temperature from Celsius to Fahrenheit.
;
; Returns:     Temperature in Fahrenheit.

CtoF_   proc
        push ebp
        mov ebp,esp

        fld real8 ptr [ebp+8]          ;load 'c'
        fmul [r8_SfCtoF]              ;ST(0) = c * 9/5
        fiadd [i4_32]                 ;ST(0) = c * 9/5 + 32

        pop ebp
        ret
CtoF_   endp
end

```

Here are the formulas that you'll need to convert a temperature value from Fahrenheit to Celsius and vice versa:

$$C = (F - 32) \times 5/9 \quad F = C \times 9/5 + 32$$

Near the top of Listing 4-2 is a `.const` directive, which defines the start of a memory block that contains constant values. Unlike the x86 general-purpose instruction set, the x87 FPU instruction set does not support using a constant value as an immediate operand. Constant values must be always loaded from memory, except for the few values supported by a constant load instruction. The `.const` section includes the two temperature conversion scale factors. The `real8` directive allocates and initializes a double-precision floating-point value. This section also declares a `dword` (32-bit) integer that contains the value 32. The other detail to note about the `.const` section is that the values are ordered to ensure proper alignment of each constant.

Immediately following the function prolog in `FtoC_`, the first x87 FPU instruction `fld [r8_5fftoC]` (Load Floating-Point Value) loads (or pushes) the constant 5/9 onto the x87 FPU register stack. The next instruction, `fld real8 ptr [ebp+8]`, loads the Fahrenheit temperature argument value onto the x87 FPU register stack. The `real8 ptr` operator informs the assembler that the size of the operand in memory is double-precision floating-point (the operator `qword ptr` could also be used here but I prefer to use `real8 ptr` since it accentuates the loading of a double-precision floating-point value).

The instruction `fld [i4_32]` (Load Integer) pushes the doubleword integer 32 from memory onto the x87 FPU stack. Subsequent to reading the operand from its memory location, the x87 FPU automatically converts the value from a signed doubleword integer to double extended-precision floating-point value, which is the format used internally by the x87 FPU. Given that this conversion process takes time, it would have been more prudent to define the constant 32 using `real8` instead of `dword`, but in this function I wanted to include an example of `fld` instruction use. Following the `fld` instruction, the x87 FPU contains three values on its register stack: the constant 32.0, the Fahrenheit temperature parameter, and the constant 5/9, as illustrated in Figure 4-1.

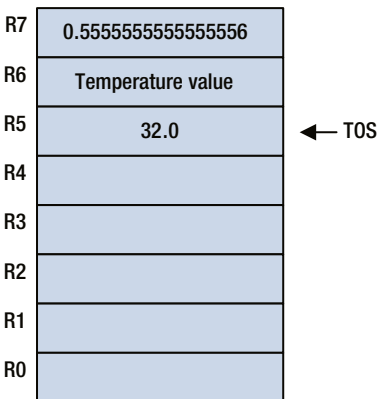

Figure 4-1. Contents of the x87 register stack after `fld` instruction

The `fsubp` (Subtract) instruction subtracts `ST(0)` from `ST(1)`, saves the difference to `ST(1)`, and pops the x87 FPU stack. Following this instruction, `ST(0)` contains the value $F - 32$ and `ST(1)` contains the value $5/9$. The `fmulp` instruction multiplies `ST(1)` by `ST(0)`, saves the product to `ST(1)`, and pops the register stack. Following execution of the `fmulp` (Multiply) instruction, `ST(0)` contains the converted temperature value in Celsius and is the sole item on the x87 FPU register stack.

The Visual C++ calling convention for 32-bit programs specifies that a function must use `ST(0)` to return a floating-point value back to its caller. All other x87 FPU registers must be empty. If a function does not need to return a floating-point value, the entire x87 FPU register stack must be empty. Functions that modify any of the flags in the x87 FPU control register must also restore these flags to their original state prior to returning. Since in the current example the x87 FPU register stack already contains the required return value, no additional instructions are needed prior to the function epilog.

The organization of function `CtoF_`, which converts a temperature value from Celsius to Fahrenheit, is similar to `FtoC_`. The main difference between these two functions is that the former performs its arithmetic calculations using memory operands, which requires fewer instructions. The `CtoF_` function starts by loading the Celsius temperature argument onto the x87 FPU stack. Next, an `fmul [r8_SfCtoF]` instruction multiplies the temperature value in `ST(0)` by $9/5$ (or 1.8) and saves the product to `ST(0)`. The final instruction `fiadd [i4_32]` (Add) adds 32 to `ST(0)`, which yields the final temperature value in degrees Fahrenheit.

The C++ file for this example, shown in Listing 4-1, contains some test cases to exercise the functions `FtoC_` and `CtoF_`. The output for sample program `TemperatureConversions` is shown in Output 4-1. Lastly, it would be remiss for me not to mention that the conversion functions of this sample program do not perform any validity checks for temperature values that are theoretically impossible. For example, a temperature of -1000 degrees Fahrenheit could be used as the argument value for `FtoC_` and the function will carry out its calculations irrespective of any physical limitations.

Output 4-1. Sample Program `TemperatureConversions`

```
i: 0 f: -459.6700 c: -273.1500
i: 1 f: -40.0000 c: -40.0000
i: 2 f: 0.0000 c: -17.7778
i: 3 f: 32.0000 c: 0.0000
i: 4 f: 72.0000 c: 22.2222
i: 5 f: 98.6000 c: 37.0000
i: 6 f: 212.0000 c: 100.0000

i: 0 c: -273.1500 f: -459.6700
i: 1 c: -40.0000 f: -40.0000
i: 2 c: -17.7700 f: 0.0140
i: 3 c: 0.0000 f: 32.0000
i: 4 c: 25.0000 f: 77.0000
i: 5 c: 37.0000 f: 98.6000
i: 6 c: 100.0000 f: 212.0000
```

Floating-Point Compares

The next sample program that you'll examine is called `CalcSphereAreaVolume`. This program demonstrates how to compare two floating-point numbers. It also illustrates use of several common x87 FPU constant-loading instructions. The C++ and assembly language source code files for `CalcSphereAreaVolume` are shown in Listings 4-3 and 4-4, respectively.

Listing 4-3. `CalcSphereAreaVolume.cpp`

```
#include "stdafx.h"

extern "C" bool CalcSphereAreaVolume_(double r, double* sa, double* v);

int _tmain(int argc, _TCHAR* argv[])
{
    double r[] = { -1.0, 0.0, 1.0, 2.0, 3.0, 5.0, 10.0, 20.0 };
    int num_r = sizeof(r) / sizeof(double);

    for (int i = 0; i < num_r; i++)
    {
        double sa = -1;
        double v = -1;
        bool rc = CalcSphereAreaVolume_(r[i], &sa, &v);

        printf("rc: %d r: %8.2lf sa: %10.4lf v: %10.4lf\n", rc, r[i], sa,
↪ v);
    }

    return 0;
}
```

Listing 4-4. `CalcSphereAreaVolume.asm`

```
.model flat,c
.const
r8_4p0 real8 4.0
r8_3p0 real8 3.0

; extern "C" bool CalcSphereAreaVolume_(double r, double* sa, double* v);
;
; Description: This function calculates the surface area and volume
;              of a sphere.
;
; Returns:     0 = invalid radius
;              1 = valid radius
```

```

.code
CalcSphereAreaVolume_ proc
    push ebp
    mov ebp,esp

; Make sure radius is valid
    xor eax,eax                                ;set error return code
    fld real8 ptr [ebp+8]                      ;ST(0) = r
    fldz                                       ;ST(0) = 0.0, ST(1) = r
    fcomip st(0),st(1)                         ;compare 0.0 to r
    fstp st(0)                                 ;remove r from stack
    jp Done                                    ;jump if unordered operands
    ja Done                                    ;jump if r < 0.0

; Calculate sphere surface area
    fld real8 ptr [ebp+8]                      ;ST(0) = r
    fld st(0)                                  ;ST(0) = r, ST(1) = r
    fmul st(0),st(0)                           ;ST(0) = r * r, ST(1) = r
    fldpi                                       ;ST(0) = pi
    fmul [r8_4p0]                              ;ST(0) = 4 * pi
    fmulp                                       ;ST(0) = 4 * pi * r * r

    mov edx,[ebp+16]
    fst real8 ptr [edx]                        ;save surface area

; Calculate sphere volume
    fmulp                                       ;ST(0) = pi * 4 * r * r * r
    fdiv [r8_3p0]                              ;ST(0) = pi * 4 * r * r * r / 3

    mov edx,[ebp+20]
    fstp real8 ptr [edx]                       ;save volume
    mov eax,1                                  ;set success return code

Done:   pop ebp
        ret
CalcSphereAreaVolume_ endp
end

```

The surface area and volume of a sphere can be calculated using the following formulas:

$$sa = 4\pi r^2 \quad v = 4\pi r^3 / 3 = (4\pi r^2)r / 3$$

Following its prolog, the function CalcSphereAreaVolume_ (Listing 4-4) performs a validity check of the sphere's radius. The argument value *r* is pushed onto the x87 FPU register stack using a `fld real8 ptr [ebp+8]` instruction. The next instruction, `fldz`

(Load Constant 0.0), loads the floating-point constant value 0.0 onto the register stack. The instruction `fcomip st(0), st(1)` (Compare Floating-Point Values and Set EFLAGS) compares ST(0) with ST(1) (or 0.0 with `r`) and sets the status flags based on the results. The `fcomip` instruction also pops the x87 FPU register stack. This is followed by an `fstp st(0)` (Store Floating-Point Value and Pop Register Stack) instruction, which removes the value `r` from the x87 FPU register stack and leaves it empty. The x87 FPU register stack is emptied before testing the status flags to ensure compliance with the Visual C++ calling convention should the value of `r` turn out to be invalid. Following cleanup of the x87 FPU register stack, there are two conditional jump instructions. A `jp Done` or `ja Done` jump is performed if `r` is a NaN (or invalid) or is less than zero.

The details of the compare operation that is performed by the `fcomip` instruction warrant closer scrutiny. This instruction subtracts ST(1) from ST(0) and sets the status flags, as shown in Table 4-1 (the difference is discarded). The x87 FPU instructions `fcomi`, `fucomi`, and `fucomip` also report their results using the same status flags. The setting of flags `EFLAGS.ZF`, `EFLAGS.PF`, and `EFLAGS.CF` by `fcomip` or one of its companion instructions enables a function to make a floating-point relational decision using a conditional jump instruction, as outlined in Table 4-2.

Table 4-1. Status Flags Set by $f(u)comi(p)$ Instructions

Condition	EFLAGS.ZF	EFLAGS.PF	EFLAGS.CF
$ST(0) > ST(i)$	0	0	0
$ST(0) = ST(i)$	1	0	0
$ST(0) < ST(i)$	0	0	1
Unordered	1	1	1

Table 4-2. Conditional Jumps Following $f(u)comi(p)$ Instructions

Relational Operator	Conditional Jump	EFLAGS Test Condition
$ST(0) < ST(i)$	<code>jb</code>	<code>CF == 1</code>
$ST(0) <= ST(i)$	<code>jbe</code>	<code>CF == 1 ZF == 1</code>
$ST(0) == ST(i)$	<code>jz</code>	<code>ZF == 1</code>
$ST(0) != ST(i)$	<code>jnz</code>	<code>ZF == 0</code>
$ST(0) > ST(i)$	<code>ja</code>	<code>CF == 0 && ZF == 0</code>
$ST(0) >= ST(i)$	<code>jae</code>	<code>CF == 0</code>

It should be noted that the status flag states shown in Table 4-1 are set only if the x87 FPU invalid operation exception (bit IM in the x87 FPU control register) is masked (the default state for Visual C++). If the invalid operation exception is unmasked, a `fcomi(p)` instruction will raise an exception if either operand is any type of NaN or is invalid. A `fucomi(p)` instruction will also raise an exception if either operand is a SNaN or invalid;

a QNaN operand causes the processor to set the status flags to indicate an unordered condition but no exception is generated. Chapter 3 contains additional information regarding the x87 FPU’s use of NaNs and ordered versus unordered compares.

If the value of *r* is valid, the function uses a `fld real8 ptr [ebp+8]` instruction to push *r* onto the x87 FPU register stack. This is followed by a `fld st(0)` instruction, which duplicates the top-most item on the x87 FPU register stack. The instruction `fmul st(0),st(0)` squares the radius and saves the result in ST(0). The `fldpi` instruction pushes the constant π onto the x87 FPU register stack. Following execution of the `fldpi` instruction, the x87 FPU register stack contains three items: the constant π in ST(0), the value $r * r$ in ST(1), and *r* in ST(2). This is shown on the left side of Figure 4-2. Final calculation of the sphere’s surface area occurs next using two multiply instructions: `fmul [r8_4p0]` followed by `fmulp`. The surface area is then saved to the memory location specified by the caller using a `fstp` instruction. Subsequent to the saving of the surface area, two values remain on the x87 FPU register stack as illustrated on the right side of Figure 4-2: the computed surface area in ST(0) and the radius in ST(1).

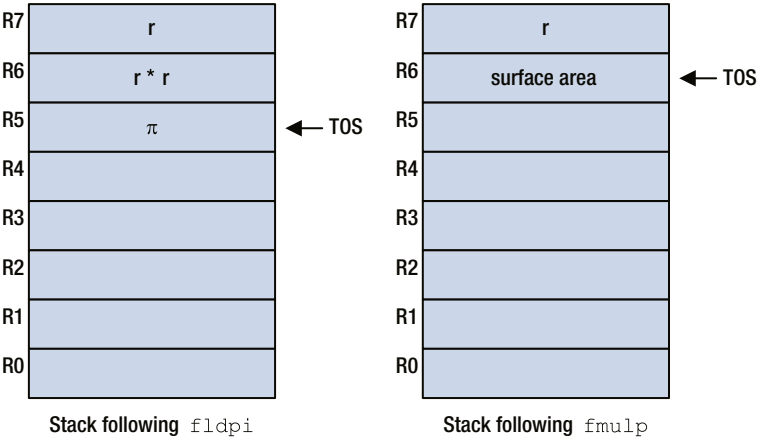

Figure 4-2. Contents of x87 register stack following the execution of the `fldpi` and `fmulp` instructions

The function computes the sphere volume using a `fmulp` instruction followed by a `fdiv [r8_3p0]` (Divide) instruction, which multiplies the surface area by the radius and divides this product by 3.0. The final sphere volume is then saved to the caller’s memory location using a `fstp real8 ptr [edx]` instruction. Following execution of this instruction, the x87 FPU register stack is empty. Output 4-2 shows the results for sample program `CalcSphereAreaVolume`.

Output 4-2. Sample Program `CalcSphereAreaVolume`

```
rc: 0 r:   -1.00 sa:  -1.0000 v:   -1.0000
rc: 1 r:    0.00 sa:   0.0000 v:    0.0000
rc: 1 r:    1.00 sa:  12.5664 v:    4.1888
```

```
rc: 1 r: 2.00 sa: 50.2655 v: 33.5103
rc: 1 r: 3.00 sa: 113.0973 v: 113.0973
rc: 1 r: 5.00 sa: 314.1593 v: 523.5988
rc: 1 r: 10.00 sa: 1256.6371 v: 4188.7902
rc: 1 r: 20.00 sa: 5026.5482 v: 33510.3216
```

X87 FPU Advanced Programming

In the previous section, you learned how to perform a few basic floating-point operations using the x87 FPU. The remainder of this chapter focuses on some advanced x87 FPU programming techniques. You'll begin with an analysis of two sample programs that process floating-point arrays. This will be followed by a sample program that illustrates the use of several x87 FPU transcendental instructions. The final sample program of the chapter highlights advanced x87 FPU register stack use.

Floating-Point Arrays

The following section contains two sample programs that illustrate using the x87 FPU to process the values in a floating-point array. The sample programs of this section also illustrate some additional x87 FPU instructions, including square roots and floating-point conditional moves.

The first sample program that you'll examine is called `CalcMeanStdev`. This program calculates the sample mean and sample standard deviation of the values in a double-precision floating-point array. Listings 4-5 and 4-6 contain the C++ and assembly language source code, respectively.

Listing 4-5. `CalcMeanStdev.cpp`

```
#include "stdafx.h"
#include <math.h>

extern "C" bool CalcMeanStdev_(const double* a, int n, double* mean, double*
stdev);

bool CalcMeanStdevCpp(const double* a, int n, double* mean, double* stdev)
{
    if (n <= 1)
        return false;

    double sum = 0.0;
    for (int i = 0; i < n; i++)
        sum += a[i];
    *mean = sum / n;

    sum = 0.0;
    for (int i = 0; i < n; i++)
```

```

    {
        double temp = a[i] - *mean;
        sum += temp * temp;
    }

    *stdev = sqrt(sum / (n - 1));
    return true;
}

int _tmain(int argc, _TCHAR* argv[])
{
    double a[] = { 10, 2, 33, 15, 41, 24, 75, 37, 18, 97};
    const int n = sizeof(a) / sizeof(double);
    double mean1, stdev1;
    double mean2, stdev2;

    CalcMeanStdevCpp(a, n, &mean1, &stdev1);
    CalcMeanStdev_(a, n, &mean2, &stdev2);

    for (int i = 0; i < n; i++)
        printf("a[%d] = %g\n", i, a[i]);

    printf("\n");
    printf("mean1: %g stdev1: %g\n", mean1, stdev1);
    printf("mean2: %g stdev2: %g\n", mean2, stdev2);
}

```

Listing 4-6. CalcMeanStdev_.asm

```

.model flat,c
.code

; extern "C" bool CalcMeanStdev(const double* a, int n, double* mean,
double* stdev);
;
; Description: The following function calculates the mean and
;              standard deviation of the values in an array.
;
; Returns:     0 = invalid 'n'
;              1 = valid 'n'

CalcMeanStdev_ proc
    push ebp
    mov ebp,esp
    sub esp,4

; Make sure 'n' is valid
    xor eax,eax

```

```

        mov ecx,[ebp+12]
        cmp ecx,1
        jle Done           ;jump if n <= 1
        dec ecx
        mov [ebp-4],ecx    ;save n - 1 for later
        inc ecx

; Compute sample mean
        mov edx,[ebp+8]    ;edx = 'a'
        fldz               ;sum = 0.0

@@:     fadd real8 ptr [edx] ;sum += *a
        add edx,8         ;a++
        dec ecx
        jnz @B
        fidiv dword ptr [ebp+12] ;mean = sum / n

; Compute sample stdev
        mov edx,[ebp+8]    ;edx = 'a'
        mov ecx,[ebp+12]  ;n
        fldz               ;sum = 0.0, ST(1) = mean

@@:     fld real8 ptr [edx] ;ST(0) = *a,
        fsub st(0),st(2)   ;ST(0) = *a - mean
        fmul st(0),st(0)  ;ST(0) = (*a - mean) ^ 2
        faddp             ;update sum
        add edx,8
        dec ecx
        jnz @B
        fidiv dword ptr [ebp-4] ;var = sum / (n - 1)
        fsqrt             ;final stdev

; Save results
        mov eax,[ebp+20]
        fstp real8 ptr [eax] ;save stdev
        mov eax,[ebp+16]
        fstp real8 ptr [eax] ;save mean
        mov eax,1           ;set success return code

Done:   mov esp,ebp
        pop ebp
        ret
CalcMeanStdev_ endp
end

```

Here are the formulas that sample program `CalcMeanStdev` uses to calculate the sample mean and sample standard deviation:

$$\bar{x} = \frac{1}{n} \sum_i x_i \qquad s = \sqrt{\frac{1}{n-1} \sum_i (x_i - \bar{x})^2}$$

■ **Note** If they're not explicitly specified, it can be assumed that the lower and upper bounds of any summation operator index appearing in this book are 0 and $n - 1$.

Immediately following its prolog, the function `CalcMeanStdev_` performs a validity check of the array element count n . In order to calculate the sample standard deviation, the number of elements in the array must be greater than or equal to 2. Following this validation, the value $n - 1$ is computed and saved to a local variable on the stack. This calculation is performed now since n is already loaded in register `ECX`. It is also faster to perform the subtraction using integer rather than floating-point arithmetic. The reason for saving $n - 1$ to a memory location is that the x86 does not support data transfers between general-purpose and x87 FPU registers.

Computation of the sample mean is straightforward and requires only seven instructions. Prior to entering a summation loop, the function `CalcMeanStdev_` uses a `mov edx, [ebp+8]` instruction to initialize register `EDX` with a pointer to array `a`. The function also uses a `fldz` instruction that allows `ST(0)` to be used as a summation variable. During the summation loop, a `fadd real8 ptr [edx]` instruction adds the current array element to the running sum in `ST(0)`. The `real8 ptr` operator is used since the data array contains double-precision floating-point values. Following addition of the current array element to the running sum in `ST(0)`, an `add edx, 8` instruction updates register `EDX` so that it points to the next array element. The summation loop is repeated until summation of the array elements is complete. The sample mean is then calculated using a `fidiv dword ptr [ebp+12]` instruction, which replaces the array element sum value in `ST(0)` with the final sample mean.

The sample standard deviation is also calculated using a summation loop. Before entering the loop, registers `EDX` and `ECX` are re-initialized as an array pointer and loop counter. A `fldz` instruction initializes the sum value to 0.0. Following the `fldz`, instruction `ST(0)` contains 0.0 and `ST(1)` contains the sample mean. Within the summation loop, each array element is loaded onto the x87 FPU register stack using a `fld real8 ptr [edx]` instruction. The `fsub st(0), st(2)` instruction subtracts the previously-computed mean from the current array element and saves the difference to `ST(0)`. This difference value is then squared using an `fmul st(0), st(0)` instruction and added to the variance sum using an `faddp` instruction. The summation loop repeats until each element of the array has been processed.

Following completion of summation loop, the x87 FPU register stack contains two values: the computed sum in `ST(0)` and the sample mean in `ST(1)`. The function uses a `fidiv dword ptr [ebp-4]` instruction to calculate the sample variance. Recall that the memory location `[ebp-4]` contains the value $n - 1$ that was derived earlier during the

validation of n . Following calculation of the sample variance, the function computes the final sample standard deviation using a `fsqrt` (Square Root) instruction, which replaces the value in `ST(0)` with its square root. The x87 FPU register stack now contains two values: the sample standard deviation in `ST(0)` and the sample mean in `ST(1)`. These values are removed from the x87 FPU stack and saved to the memory locations specified by the caller using the `fstp` instruction. Output 4-3 shows the results for sample program `CalcMeanStdev`.

Output 4-3. Sample Program `CalcMeanStdev`

```
a[0] = 10
a[1] = 2
a[2] = 33
a[3] = 15
a[4] = 41
a[5] = 24
a[6] = 75
a[7] = 37
a[8] = 18
a[9] = 97
```

```
mean1: 35.2 stdev1: 29.8358
mean2: 35.2 stdev2: 29.8358
```

The second sample program of this section, called `CalcMinMax`, determines the minimum and maximum values of a single-precision floating-point array. The C++ and assembly language files are shown in Listings 4-7 and 4-8, respectively.

Listing 4-7. `CalcMinMax.cpp`

```
#include "stdafx.h"
#include <float.h>

extern "C" bool CalcMinMax_(const float* a, int n, float* min, float* max);

bool CalcMinMaxCpp(const float* a, int n, float* min, float* max)
{
    if (n <= 0)
        return false;

    float min_a = FLT_MAX;
    float max_a = -FLT_MAX;

    for (int i = 0; i < n; i++)
    {
        if (a[i] < min_a)
            min_a = a[i];
    }
}
```

```

        if (a[i] > max_a)
            max_a = a[i];
    }

    *min = min_a;
    *max = max_a;
    return true;
}

int _tmain(int argc, _TCHAR* argv[])
{
    float a[] = { 20, -12, 42, 97, 14, -26, 57, 74, -18, 63, 34, -9};
    const int n = sizeof(a) / sizeof(float);
    float min1, max1;
    float min2, max2;

    CalcMinMaxCpp(a, n, &min1, &max1);
    CalcMinMax_(a, n, &min2, &max2);

    for (int i = 0; i < n; i++)
        printf("a[%2d] = %8.2f\n", i, a[i]);

    printf("\n");
    printf("min1: %8.2f  max1: %8.2f\n", min1, max1);
    printf("min2: %8.2f  max2: %8.2f\n", min2, max2);
}

```

Listing 4-8. CalcMinMax_.asm

```

        .model flat,c
        .const
r4_MinFloat dword 0ff7fffffh           ;smallest float number
r4_MaxFloat dword 7f7fffffh           ;largest float number
        .code

; extern "C" bool CalcMinMax_(const float* a, int n, float* min, float*
max);
;
; Description: The following function calculates the min and max values
;              of a single-precision floating-point array.
;
; Returns:     0 = invalid 'n'
;              1 = valid 'n'

CalcMinMax_ proc
    push ebp
    mov ebp,esp

```

```

; Load argument values and make sure 'n' is valid.
    xor  eax,eax                ;set error return code
    mov  edx,[ebp+8]           ;edx = 'a'
    mov  ecx,[ebp+12]         ;ecx = 'n'
    test ecx,ecx
    jle  Done                  ;jump if 'n' <= 0

    fld  [r4_MinFloat]        ;initial max_a value
    fld  [r4_MaxFloat]        ;initial min_a value

; Find min and max of input array
@@:   fld  real4 ptr [edx]     ;load *a
      fld  st(0)              ;duplicate *a on stack

      fcomi st(0),st(2)       ;compare *a with min
      fcmovnb st(0),st(2)    ;ST(0) equals smaller val
      fstp st(2)              ;save new min value

      fcomi st(0),st(2)       ;compare *a with max_a
      fcmovb st(0),st(2)     ;st(0) equals larger val
      fstp st(2)              ;save new max value

      add  edx,4              ;point to next a[i]
      dec  ecx
      jnz  @@B                ;repeat loop until finished

; Save results
    mov  eax,[ebp+16]
    fstp real4 ptr [eax]     ;save final min
    mov  eax,[ebp+20]
    fstp real4 ptr [eax]     ;save final max
    mov  eax,1               ;set success return code

Done:  pop  ebp
      ret

CalcMinMax_ endp
      end

```

Following a validation check of `n`, `CalcMinMax_` uses a `fld [r4_MinFloat]` instruction to initialize `max_a` on the x87 FPU register stack. This is followed by an `fld [r4_MaxFloat]` instruction that initializes `min_a`. The memory operands `[r4_MinFloat]` and `[r4_MaxFloat]` are defined in the `.const` section and contain the hexadecimal encodings for the smallest and largest single-precision floating-point values supported by the x87 FPU.

The processing loop in `CalcMinMax_` loads two copies of the current array element onto the x87 FPU register stack using a `fld real4 ptr [edx]` instruction followed by a `fld st(0)` instruction. After execution of these instructions, the x87 FPU register stack contains `a[i]`, `a[i]`, `min_a`, and `max_a`, as shown in Figure 4-3. The `fcomi st(0),st(2)`

instruction compares `a[i]` to `min_a` and sets the status flags in EFLAGS. A conditional move instruction, `fcmovnb st(0),st(2)` (Floating-Point Conditional Move), ensures that ST(0) contains the smaller of these two values. Next, a `fstp st(2)` instruction copies ST(0) to ST(2) and pops the x87 FPU register stack, which updates the value of `min_a` on the stack. Following execution of the `fstp st(2)` instruction, the x87 FPU register stack contains `a[i]`, `min_a`, and `max_a`.

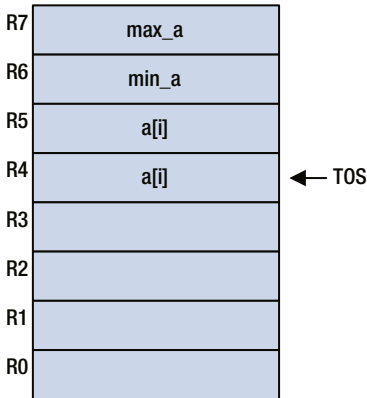

Figure 4-3. Contents of the x87 register stack following execution of the `fld st(0)` instruction

`CalcMinMax_` uses a similar series of instructions to update `max_a`. A `fcomi st(0),st(2)` instruction compares `a[i]` to `max_a` and a `fcmovb st(0),st(2)` instruction ensures that ST(0) contains the larger value. Next, a `fstp st(2)` instruction updates the value of `max_a` on the x87 FPU register stack. Upon completion of the processing loop, the x87 FPU register stack contains the final `min_a` and `max_a`. These values are then saved to the required memory locations. The output for `CalcMinMax` is shown in Output 4-4.

Output 4-4. Sample Program `CalcMinMax`

```

a[ 0] = 20.00
a[ 1] = -12.00
a[ 2] = 42.00
a[ 3] = 97.00
a[ 4] = 14.00
a[ 5] = -26.00
a[ 6] = 57.00
a[ 7] = 74.00
a[ 8] = -18.00
a[ 9] = 63.00
a[10] = 34.00
a[11] = -9.00

min1: -26.00 max1: 97.00
min2: -26.00 max2: 97.00

```

Transcendental Instructions

The next sample program is named `ConvertCoordinates`. This program demonstrates how to use some of the x87 FPU's transcendental instructions. The program includes a couple of functions that perform coordinate conversions using rectangular and polar coordinates. Listings 4-9 and 4-10 contain the C++ and x86 assembly language code for the sample program `ConvertCoordinates`.

Listing 4-9. `ConvertCoordinates.cpp`

```
#include "stdafx.h"

extern "C" void RectToPolar_(double x, double y, double* r, double* a);
extern "C" void PolarToRect_(double r, double a, double* x, double* y);

int _tmain(int argc, _TCHAR* argv[])
{
    double x1[] = { 0, 3, -3, 4, -4 };
    double y1[] = { 0, 3, -3, 4, -4 };
    const int nx = sizeof(x1) / sizeof(double);
    const int ny = sizeof(y1) / sizeof(double);

    for (int i = 0; i < ny; i++)
    {
        for (int j = 0; j < nx; j++)
        {
            double r, a, x2, y2;

            RectToPolar_(x1[i], y1[j], &r, &a);
            PolarToRect_(r, a, &x2, &y2);

            printf("[%d, %d]: ", i, j);
            printf("(%8.4lf, %8.4lf) ", x1[i], y1[j]);
            printf("(%8.4lf, %10.4lf) ", r, a);
            printf("(%8.4lf, %8.4lf)\n", x2, y2);
        }
    }

    return 0;
}
```

Listing 4-10. `ConvertCoordinates.asm`

```
.model flat,c
.const
DegToRad real8 0.01745329252
RadToDeg real8 57.2957795131
.code
```

```
; extern "C" void RectToPolar_(double x, double y, double* r, double* a);
;
; Description: This function converts a rectangular coordinate to a
;               to polar coordinate.
```

```
RectToPolar_ proc
    push ebp
    mov ebp,esp

; Calculate the angle. Note that fpatan computes atan2(ST(1) / ST(0))
    fld real8 ptr [ebp+16]           ;load y
    fld real8 ptr [ebp+8]           ;load x
    fpatan                          ;calc atan2 (y / x)
    fmul [RadToDeg]                 ;convert angle to degrees
    mov eax,[ebp+28]
    fstp real8 ptr [eax]            ;save angle

; Calculate the radius
    fld real8 ptr [ebp+8]           ;load x
    fmul st(0),st(0)                ;x * x
    fld real8 ptr [ebp+16]         ;load y
    fmul st(0),st(0)                ;y * y
    faddp                            ;x * x + y * y
    fsqrt                            ;sqrt(x * x + y * y)
    mov eax,[ebp+24]
    fstp real8 ptr [eax]            ;save radius

    pop ebp
    ret
RectToPolar_   endp
```

```
; extern "C" void PolarToRect_(double r, double a, double* x, double* y);
;
; Description: The following function converts a polar coordinate
;               to a rectangular coordinate.
```

```
PolarToRect_ proc
    push ebp
    mov ebp,esp

; Calculate sin(a) and cos(a).
; Following execution of fsincos, ST(0) = cos(a) and ST(1) = sin(a)
    fld real8 ptr [ebp+16]         ;load angle in degrees
    fmul [DegToRad]                ;convert angle to radians
    fsincos                         ;calc sin(ST(0)) and cos(ST(0))

    fmul real8 ptr [ebp+8]         ;x = r * cos(a)
```

```

    mov eax,[ebp+24]
    fstp real8 ptr [eax]           ;save x

    fmul real8 ptr [ebp+8]         ;y = r * sin(a)
    mov eax,[ebp+28]
    fstp real8 ptr [eax]         ;save y

    pop ebp
    ret
PolarToRect_   endp
                end

```

Before examining the source code, let's quickly review the rudiments of a two-dimensional coordinate system. A point on a two-dimensional plane can be uniquely specified using an (x, y) ordered pair. The values for x and y represent signed distances from an origin point, which is located at the intersection of two perpendicular axes. An ordered (x, y) pair is called a rectangular or Cartesian coordinate. A point on a two-dimensional plane also can be uniquely specified using a radius vector r and angle θ , as illustrated in Figure 4-4. An ordered (r, θ) pair is called a polar coordinate.

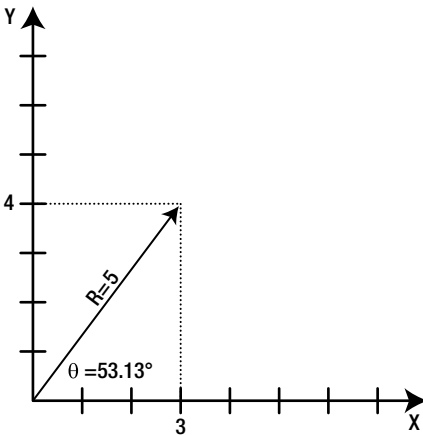

Figure 4-4. Specification of a point using rectangular and polar coordinates

Conversion between rectangular and polar coordinates is accomplished using the following formulas:

$$r = \sqrt{x^2 + y^2} \quad \theta = \text{atan2}(y/x) \text{ where } -\pi \leq \theta \leq +\pi$$

$$x = r \cos(\theta) \quad y = r \sin(\theta)$$

The file `ConvertCoordinates.asm` contains a function called `RectToPolar_` that converts a rectangular coordinate to a polar coordinate. Immediately following the function prolog, the argument values `y` and `x` are loaded onto the register stack using two `fld` instructions. The next instruction, `fpatan` (Partial Arctangent), calculates `atan2(st(1)/st(0))`, stores the resultant angle in `ST(1)`, and pops the x87 FPU stack. A `fmul [RadToDeg]` instruction converts the angle value, which is stored in `ST(0)`, from radians to degrees. The polar coordinate angle is then saved to the caller's specified memory location.

The value of `r` is calculated as follows. A `fld real8 ptr [ebp+8]` instruction loads `x` onto the x87 FPU stack. The square of `x` is calculated using a `fmul st(0),st(0)` instruction. The square of `y` is calculated next, using a similar sequence of instructions. A `faddp` instruction sums the squares and the final radius value is computed using `fsqrt`. The polar coordinate radius is then saved to the specified memory location.

The inverse of function `RectToPolar_` is called `PolarToRect_`. It begins by loading the polar angle value onto the x87 FPU register stack using a `fld real8 ptr [ebp+16]` instruction. A `fmul [DegToRad]` instruction converts the angle from degrees to radians. This is followed by a `fsincos` (Sine and Cosine) instruction, which calculates both the sine and cosine of the value in `ST(0)`. Upon completion of the `fsincos` instruction, `ST(0)` and `ST(1)` contain the cosine and sine, respectively. As a side note, the x87 FPU also includes the instructions `fsin` and `fcos`; however, use of the `fsincos` instruction is faster when both values are needed.

A `fmul real8 ptr [ebp+8]` instruction multiplies the polar angle's cosine by the polar radius, which yields the rectangular `x` coordinate. This value is then saved to the specified memory location. A similar sequence of instructions calculates the rectangular `y` coordinate by multiplying the polar angle's sine and radius. Output 4-5 shows the output for sample program `ConvertCoordinates`.

Output 4-5. Sample Program `ConvertCoordinates`

```
[0, 0]: ( 0.0000, 0.0000) ( 0.0000, 0.0000) ( 0.0000, 0.0000)
[0, 1]: ( 0.0000, 3.0000) ( 3.0000, 90.0000) (-0.0000, 3.0000)
[0, 2]: ( 0.0000, -3.0000) ( 3.0000, -90.0000) (-0.0000, -3.0000)
[0, 3]: ( 0.0000, 4.0000) ( 4.0000, 90.0000) (-0.0000, 4.0000)
[0, 4]: ( 0.0000, -4.0000) ( 4.0000, -90.0000) (-0.0000, -4.0000)
[1, 0]: ( 3.0000, 0.0000) ( 3.0000, 0.0000) ( 3.0000, 0.0000)
[1, 1]: ( 3.0000, 3.0000) ( 4.2426, 45.0000) ( 3.0000, 3.0000)
[1, 2]: ( 3.0000, -3.0000) ( 4.2426, -45.0000) ( 3.0000, -3.0000)
[1, 3]: ( 3.0000, 4.0000) ( 5.0000, 53.1301) ( 3.0000, 4.0000)
[1, 4]: ( 3.0000, -4.0000) ( 5.0000, -53.1301) ( 3.0000, -4.0000)
[2, 0]: ( -3.0000, 0.0000) ( 3.0000, 180.0000) (-3.0000, -0.0000)
[2, 1]: ( -3.0000, 3.0000) ( 4.2426, 135.0000) (-3.0000, 3.0000)
[2, 2]: ( -3.0000, -3.0000) ( 4.2426, -135.0000) (-3.0000, -3.0000)
[2, 3]: ( -3.0000, 4.0000) ( 5.0000, 126.8699) (-3.0000, 4.0000)
[2, 4]: ( -3.0000, -4.0000) ( 5.0000, -126.8699) (-3.0000, -4.0000)
[3, 0]: ( 4.0000, 0.0000) ( 4.0000, 0.0000) ( 4.0000, 0.0000)
[3, 1]: ( 4.0000, 3.0000) ( 5.0000, 36.8699) ( 4.0000, 3.0000)
[3, 2]: ( 4.0000, -3.0000) ( 5.0000, -36.8699) ( 4.0000, -3.0000)
[3, 3]: ( 4.0000, 4.0000) ( 5.6569, 45.0000) ( 4.0000, 4.0000)
[3, 4]: ( 4.0000, -4.0000) ( 5.6569, -45.0000) ( 4.0000, -4.0000)
```



```
[4, 0]: ( -4.0000,  0.0000) (  4.0000,  180.0000) ( -4.0000,  -0.0000)
[4, 1]: ( -4.0000,  3.0000) (  5.0000,  143.1301) ( -4.0000,   3.0000)
[4, 2]: ( -4.0000, -3.0000) (  5.0000, -143.1301) ( -4.0000, -3.0000)
[4, 3]: ( -4.0000,  4.0000) (  5.6569,  135.0000) ( -4.0000,  4.0000)
[4, 4]: ( -4.0000, -4.0000) (  5.6569, -135.0000) ( -4.0000, -4.0000)
```

Advanced Stack Usage

Thus far the sample programs of this chapter haven't stressed the limits of the x87 register stack. This will change in the final x87 FPU sample program, which is called `CalcLeastSquares`. In `CalcLeastSquares`, you'll learn how to calculate a least squares regression line using the x87 FPU. The source code for `CalcLeastSquares.cpp` and `CalcLeastSquares_.asm` is shown in Listings 4-11 and 4-12, respectively.

Listing 4-11. `CalcLeastSquares.cpp`

```
#include "stdafx.h"
#include <math.h>

extern "C" double LsEpsilon_;
extern "C" bool CalcLeastSquares_(const double* x, const double* y, int n,
double* m, double* b);

bool CalcLeastSquaresCpp(const double* x, const double* y, int n, double* m,
double* b)
{
    if (n <= 0)
        return false;

    double sum_x = 0;
    double sum_y = 0;
    double sum_xx = 0;
    double sum_xy = 0;

    for (int i = 0; i < n; i++)
    {
        sum_x += x[i];
        sum_xx += x[i] * x[i];
        sum_xy += x[i] * y[i];
        sum_y += y[i];
    }

    double denom = n * sum_xx - sum_x * sum_x;

    if (LsEpsilon_ >= fabs(denom))
        return false;
```

```

*m = (n * sum_xy - sum_x * sum_y) / denom;
*b = (sum_xx * sum_y - sum_x * sum_xy) / denom;
return true;
}

int _tmain(int argc, _TCHAR* argv[])
{
    const int n = 7;
    double x[n] = { 0, 2, 4, 6, 8, 10, 12};
    double y[n] = { 51.125, 62.875, 71.25, 83.5, 92.75, 101.1, 110.5 };
    double m1 = 0, m2 = 0;
    double b1 = 0, b2 = 0;
    bool rc1, rc2;

    rc1 = CalcLeastSquaresCpp(x, y, n, &m1, &b1);
    rc2 = CalcLeastSquares_(x, y, n, &m2, &b2);

    for (int i = 0; i < n; i++)
        printf("%12.4lf, %12.4lf\n", x[i], y[i]);

    printf("\n");
    printf("rc1: %d m1: %12.4lf b1: %12.4lf\n", rc1, m1, b1);
    printf("rc2: %d m2: %12.4lf b2: %12.4lf\n", rc2, m2, b2);
    return 0;
}

```

Listing 4-12. CalcLeastSquares_.asm

```

.model flat,c
.const
public LsEpsilon_
LsEpsilon_ real8 1.0e-12 ;epsilon for valid denom test
.code

; extern "C" bool CalcLeastSquares_(const double* x, const double* y, int n,
double* m, double* b);
;
; Description: The following function computes the slope and intercept
; of a least squares regression line.
;
; Returns 0 = error
; 1 = success

CalcLeastSquares_ proc
    push ebp
    mov ebp,esp
    sub esp,8 ;space for denom

```

```

        xor eax,eax                ;set error return code
        mov ecx,[ebp+16]          ;n
        test ecx,ecx
        jle Done                  ;jump if n <= 0
        mov eax,[ebp+8]           ;ptr to x
        mov edx,[ebp+12]          ;ptr to y

; Initialize all sum variables to zero
        fldz                       ;sum_xx
        fldz                       ;sum_xy
        fldz                       ;sum_y
        fldz                       ;sum_x
;STACK: sum_x, sum_y, sum_xy, sum_xx

@@:    fld real8 ptr [eax]         ;load next x
        fld st(0)
        fld st(0)
        fld real8 ptr [edx]       ;load next y
;STACK: y, x, x, x, sum_x, sum_y, sum_xy, sum_xx

        fadd st(5),st(0)          ;sum_y += y
        fmulp
;STACK: xy, x, x, sum_x, sum_y, sum_xy, sum_xx

        faddp st(5),st(0)         ;sum_xy += xy
;STACK: x, x, sum_x, sum_y, sum_xy, sum_xx

        fadd st(2),st(0)          ;sum_x += x
        fmulp
;STACK: xx, sum_x, sum_y, sum_xy, sum_xx

        faddp st(4),st(0)         ;sum_xx += xx
;STACK: sum_x, sum_y, sum_xy, sum_xx

; Update pointers and repeat until elements have been processed.
        add eax,8
        add edx,8
        dec ecx
        jnz @B

; Compute denom = n * sum_xx - sum_x * sum_x
        fild dword ptr [ebp+16]   ;n
        fmul st(0),st(4)          ;n * sum_xx
;STACK: n * sum_xx, sum_x, sum_y, sum_xy, sum_xx

        fld st(1)
        fld st(0)
;STACK: sum_x, sum_x, n * sum_xx, sum_x, sum_y, sum_xy, sum_xx

```

```

    fmulp
    fsubp
    fst real8 ptr [ebp-8]          ;save denom
;STACK: denom, sum_x, sum_y, sum_xy, sum_xx

; Verify that denom is valid
    fabs                          ;fabs(denom)
    fld real8 ptr [LsEpsilon_]
    fcomip st(0),st(1)           ;compare epsilon and fabs(denom)
    fstp st(0)                   ;remove fabs(denom) from stack
    jae InvalidDenom            ;jump if LsEpsilon_ >=fabs(denom)
;STACK: sum_x, sum_y, sum_xy, sum_xx

; Compute slope = (n * sum_xy - sum_x * sum_y) / denom
    fild dword ptr [ebp+16]
;STACK: n, sum_x, sum_y, sum_xy, sum_xx

    fmul st(0),st(3)             ;n * sum_xy
    fld st(2)                    ;sum_y
    fld st(2)                    ;sum_x
    fmulp                        ;sum_x * sum_y
    fsubp                        ;n * sum_xy - sum_x * sum_y
    fdiv real8 ptr [ebp-8]       ;calculate slope
    mov eax,[ebp+20]
    fstp real8 ptr [eax]        ;save slope
;STACK: sum_x, sum_y, sum_xy, sum_xx

; Calculate intercept = (sum_xx * sum_y - sum_x * sum_xy) / denom
    fxch st(3)
;STACK: sum_xx, sum_y, sum_xy, sum_x

    fmulp
    fxch st(2)
;STACK: sum_x, sum_xy, sum_xx * sum_y

    fmulp
    fsubp
;STACK: sum_xx * sum_y - sum_x * sum_xy

    fdiv real8 ptr [ebp-8]       ;calculate intercept
    mov eax,[ebp+24]
    fstp real8 ptr [eax]        ;save intercept
    mov eax,1                   ;set success return code

Done:  mov esp,ebp
       pop ebp
       ret

```

```

InvalidDenom:
; Cleanup x87 FPU register stack
    fstp st(0)
    fstp st(0)
    fstp st(0)
    fstp st(0)
    xor eax,eax                ;set error return code
    mov esp,ebp
    pop ebp
    ret
CalcLeastSquares_ endp
end

```

Simple linear regression is a statistical technique that models a linear relationship between two variables. One popular method of simple linear regression is called least squares fitting, which uses a set of sample data points to determine a best fit or optimal curve between two variables. When used with a simple linear regression model, the curve is a straight line whose equation is $y = mx + b$. In this equation, x denotes the independent variable, y represents the dependent (or measured) variable, m is the line's slope, and b is the line's y -axis intercept point. The slope and intercept of a least squares line are determined using a series of computations that minimize the sum of the squared deviations between the line and sample data points. Following calculation of the slope and intercept values, the least squares line is frequently used to predict an unknown y value using a known x value. If you're interested in learning more about the theory of simple linear regression and least squares fitting, consult the resources listed in Appendix C.

In sample program `CalcLeastSquares`, the following formulas are used to calculate the least squares slope and intercept point:

$$m = \frac{n \sum_i x_i y_i - \sum_i x_i \sum_i y_i}{n \sum_i x_i^2 - \left(\sum_i x_i \right)^2} \quad b = \frac{\sum_i x_i^2 \sum_i y_i - \sum_i x_i \sum_i x_i y_i}{n \sum_i x_i^2 - \left(\sum_i x_i \right)^2}$$

At first glance, the slope and intercept equations may appear a little daunting. However, upon closer examination, a couple of simplifications become apparent. First, the slope and intercept denominators are the same, which means that this value only needs to be computed once. Second, it is only necessary to calculate four simple summation quantities (or sum variables), as shown in the following formulas:

$$\begin{aligned} \text{sum_x} &= \sum_i x_i & \text{sum_y} &= \sum_i y_i \\ \text{sum_xy} &= \sum_i x_i y_i & \text{sum_xx} &= \sum_i x_i^2 \end{aligned}$$

Subsequent to the calculation of the sum variables, the least-squares slope and intercept are easily derived using straightforward multiplication, subtraction, and division.

The function `CalcLeastSquares_` is somewhat more complicated than the other x87 FPU functions discussed in this chapter in that it uses all eight positions in the x87 FPU register stack. When coding an x87 FPU function that uses more than four entries in the x87 FPU register stack, I find it helpful to include occasional comments in the source code that document the values stored on the stack. In Listing 4-12, comment lines that begin with the word `STACK` denote the contents of the x87 FPU register stack following execution of the instruction immediately above the comment. The stack contents are listed in order from top to bottom starting with `ST(0)`.

Let's review the source code for the function `CalcLeastSquares_`. Following a validity check of `n`, a series of `fldz` instructions initializes `sum_x`, `sum_y`, `sum_xy`, and `sum_xx` to 0.0. The order of the sum variables in the previous sentence represents their position on the x87 FPU register stack starting with `ST(0)`. This sequence will not change during execution of the processing loop but the positions of the sum variables relative to the stack top will vary. While use of the x87 FPU register stack for intermediate values increases the complexity of the algorithm slightly, it also results in better performance compared to using intermediate values in memory.

Subsequent to the initialization of the sum variables to 0.0, the function enters a loop that iterates through the data points and computes the sum variables. At the top of the loop, the current `x` and `y` values are loaded onto the x87 FPU register stack using a series of `fld` instructions. Immediately following execution of these instructions, the x87 FPU register stack is *completely* full, as shown in Figure 4-5 (the value `sum_xx` would be lost if another value were loaded onto the x87 FPU register stack). The sum variables are then updated using a series of floating-point additions and multiplications. Note that some of the `fadd` instructions use a destination operand other than `ST(0)`. It is also important to notice that the relative positions of the sum variables on the stack change as computations are performed. Upon completion of the iteration loop, the x87 FPU stack contains the final values of the four sum variables.

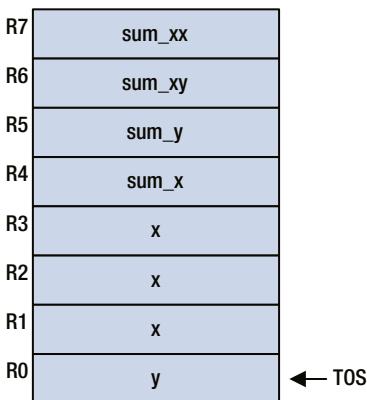

Figure 4-5. Contents of the x87 FPU stack following execution of the `fld real8 ptr [edx]` instruction

Calculation of the common slope-intercept denominator (*denom*) occurs next. This requires the function to calculate two intermediate values, $n * \text{sum_xx}$ and $\text{sum_x} * \text{sum_x}$, using variations of the `fild` and `fmul` instructions. Once these values are calculated, the latter product is subtracted from the former product to generate the final value of *denom*. This value is then saved to a temporary local variable on the x86 stack. Before proceeding to the next calculation, the value of *denom* is validated to prevent a division-by-zero error. If *denom* is invalid, program control is transferred to a block of code near the end of function `CalcLeastSquares_` that cleans up the x87 FPU stack, loads register `EAX` with the appropriate error code, and returns to the caller.

Following calculation of *denom*, the function computes the least-squares slope. During calculation of the slope, the order of the sum variables on the x87 FPU stack is maintained since these values will also be needed to calculate the intercept. The final slope value is saved to the caller-specified memory location. Computation of the least-squares intercept value requires the use of two `fych` instructions. The reason for this is that all x87 FPU arithmetic instructions must use `ST(0)` either as an implicit or explicit operand. The final `fstp` instruction saves the intercept value to the caller's specified memory location and yields an empty x87 FPU register stack. Output 4-6 shows the results for sample program `CalcLeastSquares`.

Output 4-6. Sample Program `CalcLeastSquares`

0.0000,	51.1250
2.0000,	62.8750
4.0000,	71.2500
6.0000,	83.5000
8.0000,	92.7500
10.0000,	101.1000
12.0000,	110.5000

rc1: 1	m1:	4.9299	b1:	52.2920
rc2: 1	m2:	4.9299	b2:	52.2920

Summary

In this chapter, you learned a little more about the architecture of the x87 FPU and how to exploit the computational capabilities of this resource in order to perform a variety of floating-point operations. Unlike the x86's general-purpose registers, effective use of the x87 FPU's stack-oriented register set requires you to adopt a slightly different mindset when writing code. This shift in approach tends to become second nature over time as you gain experience with the architecture.

If you are familiar with the scalar floating-point capabilities of x86-SSE, you may question why I spent quite a few pages explaining features and discussing sample code of an architecture that many consider deprecated. I did it for a number of reasons. First, despite any perceptions of deprecation, the x87 FPU's architecture and instruction set will

remain relevant for the foreseeable future due to the tremendous amount of legacy code that exists. Another reason is that the Visual C++ calling convention for 32-bit programs still uses the x87 FPU register stack for floating-point return values even if the compiler is configured to generate floating-point code using SSE2 instructions. This means that many developers will need at least a basic understanding of the x87 FPU. Finally, ultra-low-power microarchitectures such as Intel's Quark do not include any of the floating-point resources provided by x86-SSE. Developers targeting Quark and similar platforms have no choice but to use the x87 FPU in code that requires floating-point arithmetic.

CHAPTER 5



MMX Technology

Chapters 1-4 focused on the essence of the x86-32 platform. You learned about the x86's basic data types, its general-purpose registers, its memory addressing modes, and the core x86-32 instruction set. You also examined a cornucopia of sample code that illustrated the nuts and bolts of x86 assembly language programming, including basic operands, integer arithmetic, compare operations, conditional jumps, and manipulation of common data structures. This was followed by an examination of the x87 FPU's architecture, including its stack-oriented register set and how to write assembly language code to perform floating-point arithmetic.

The next twelve chapters concentrate on the single instruction multiple data (SIMD) capabilities of the x86 platform. This chapter examines the x86's first SIMD extension, which is called MMX technology. MMX technology adds integer SIMD processing to the x86 platform. The chapter opens with an explanation of some basic SIMD processing concepts. It then describes the difference between wraparound and saturated integer arithmetic and when it's appropriate to use the latter. This is followed by a discussion of the MMX execution environment, including its register set and supported data types. The chapter concludes with a summary of the MMX instruction set.

MMX technology defines a basis for subsequent x86 SIMD extensions including x86-SSE and x86-AVX, which are discussed in Chapters 7 through 16. If your ultimate objective is to create software that exploits one of the newer SIMD extensions, attaining a thorough understanding of this chapter's content is strongly recommended since it will ultimately reduce the time that you spend on the x86 SIMD learning curve.

SIMD Processing Concepts

Before examining the particulars of MMX technology, this section reviews some basic SIMD processing concepts. As implied by the words of its acronym, a SIMD computing element performs the same operation on multiple data items simultaneously. Typical SIMD operations include basic arithmetic (addition, subtraction, multiplication, and division), shifts, compares, and data conversions. Processors facilitate SIMD operations by reinterpreting the bit pattern of an operand in a register or memory location. A 32-bit register, for example, can contain a single 32-bit integer value. It is also capable of accommodating two 16-bit integers or four 8-bit integers, as illustrated in Figure 5-1.

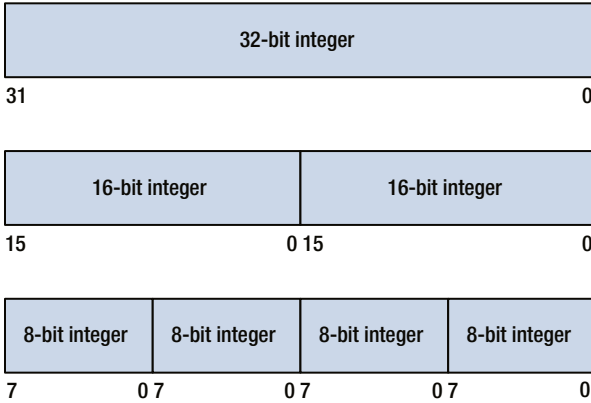

Figure 5-1. 32-bit register using multiple integer sizes

The bit patterns shown in Figure 5-1 make it possible to perform an operation using each distinct data element. Figure 5-2 exemplifies this in greater detail. In this figure, integer addition is illustrated using a single 32-bit integer, two 16-bit integers, and four 8-bit integers. Processing performance improvements are possible when multiple data items are used since the processor can carry out the required operations in parallel. In Figure 5-2, the processor can simultaneously perform each 16-bit or 8-bit integer addition using the supplied operands.

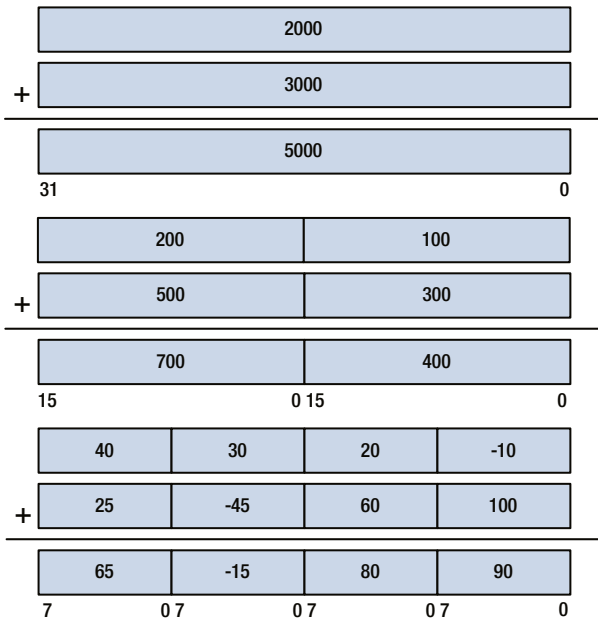

Figure 5-2. Example of SIMD integer addition

On the x86 platform, MMX technology supports 64-bit wide registers and memory operands. This means that a SIMD operation can be performed using two 32-bit, four 16-bit, or eight 8-bit values. Moreover, MMX SIMD operations are not limited to simple arithmetic operations such as addition and subtraction. Other common operations such as shifts, Boolean operations, compares, and data conversions are also possible. MMX technology also supports a number of atomic high-level operations that normally require several instructions to complete. Figure 5-3 illustrates execution of the MMX `pmaxub` (Maximum of Packed Unsigned Byte Integers) instruction using 64-bit MM registers containing 8-bit unsigned integers. In this example, the processor compares each 8-bit unsigned integer pair, separately and simultaneously, and stores the larger value in the destination operand. You'll take a closer look at the MMX instruction set later in this chapter.

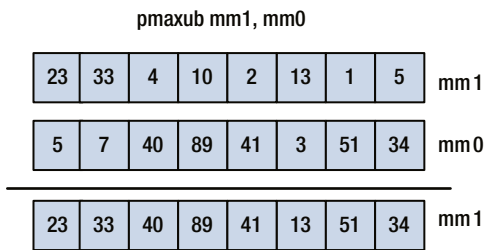

Figure 5-3. Operation of MMX `pmaxub` instruction

Wraparound vs. Saturated Arithmetic

One extremely useful feature of MMX technology is its support for saturated integer arithmetic. In saturated integer arithmetic, computational results are automatically clipped by the processor to prevent overflow and underflow conditions. This differs from normal wraparound integer arithmetic where an overflow or underflow result is retained. Saturated arithmetic is handy when working with pixel values since it eliminates the need to explicitly check the result of each pixel calculation for an overflow or underflow condition. MMX technology includes instructions that perform saturated arithmetic using 8-bit and 16-bit integers, both signed and unsigned.

Let's take a closer look at some examples of wraparound and saturated arithmetic. Figure 5-4 shows an example of 16-bit signed integer addition using both wraparound and saturated arithmetic. An overflow condition occurs if the two 16-bit signed integers are added using wraparound arithmetic. With saturated arithmetic, however, the result is clipped to the largest possible 16-bit signed integer value. Figure 5-5 illustrates a similar example using 8-bit unsigned integers. Besides addition, MMX technology also supports saturated integer subtraction, as shown in Figure 5-6. Table 5-1 summarizes the saturated arithmetic range limits for all possible integer sizes and sign types.

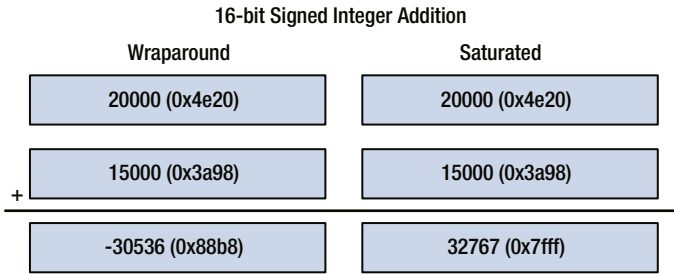

Figure 5-4. 16-bit signed integer addition using wraparound and saturated arithmetic

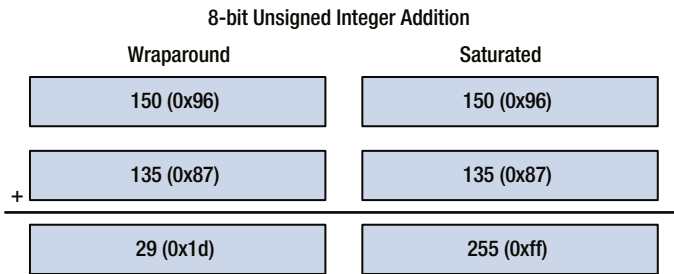

Figure 5-5. 8-bit unsigned integer addition using wraparound and saturated arithmetic

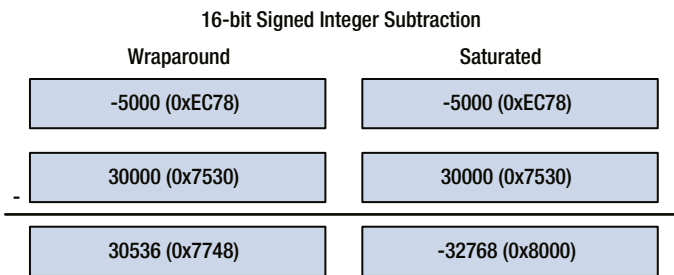

Figure 5-6. 16-bit signed integer subtraction using wraparound and saturated arithmetic

Table 5-1. Range Limits for Saturated Arithmetic

Integer Type	Lower Limit	Upper Limit
8-bit signed	-128 (0x80)	+127 (0x7f)
8-bit unsigned	0	+255 (0xff)
16-bit signed	-32768 (0x8000)	+32767 (0x7fff)
16-bit unsigned	0	+65535 (0xffff)

MMX Execution Environment

From the perspective of an application program, MMX technology adds eight 64-bit registers to the core x86-32 platform. These registers, shown in Figure 5-7, are named MM0–MM7 and can be used to perform SIMD operations using eight 8-bit integers, four 16-bit integers, or two 32-bit integers. Both signed and unsigned integers are supported. The MMX registers also can be used to carry out a limited number of operations using 64-bit integers. Unlike the x87 FPU register set, the MMX registers are directly addressable; a stack-based architecture is not used. The MMX registers cannot be used to perform floating-point arithmetic or address operands located in memory. Figure 5-8 illustrates the packed data types that are supported by MMX.

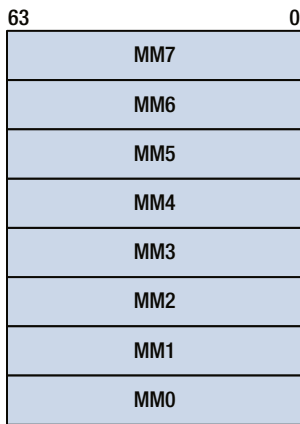

Figure 5-7. MMX register set

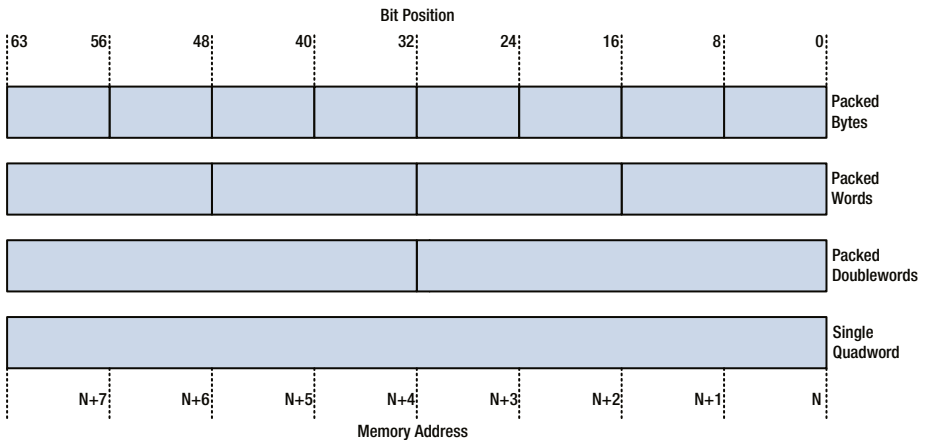

Figure 5-8. MMX data types

Within an x86 processor, the MMX registers are aliased with the x87 FPU registers. This means that the MMX and x87 FPU registers use the same storage bits. The aliasing of the MMX and x87 FPU registers imposes some restrictions on intermixing MMX and x87 FPU instructions. In order to avoid conflicts between the MMX and x87 FPU execution units, MMX state information must be cleared using the `emms` (Empty MMX Technology State) instruction whenever a transition from executing MMX instructions to executing x87 FPU instructions occurs. The sample code in Chapter 6 illustrates this requirement in greater detail. Failure to properly use the `emms` instruction may cause the x87 FPU to generate an unexpected exception or compute an invalid result.

MMX Instruction Set

This section presents a brief overview of the MMX instruction set. Similar to the instruction set reviews in Chapters 1 and 3, the purpose of this section is to provide you with a general understanding of the MMX instruction set. Comprehensive information regarding each MMX instruction, including valid operands and potential exceptions, is available in the reference manuals published by AMD and Intel. A list of these manuals is included in Appendix C. The sample code that's discussed in Chapter 6 also contains additional details regarding MMX instruction set use.

The MMX instruction set can be partitioned into the following eight functional groups:

- Data transfer
- Arithmetic
- Comparison
- Conversion
- Logical and Shift
- Unpack and Shuffle
- Insertion and Extraction
- State and Cache Control

The instruction set overview surveys all of the instructions that were included with the initial release of MMX. It also encompasses MMX instructions that were added as part of an x86-SSE enhancement (e.g. SSE, SSE2, SSE3, or SSSE3). The summary tables include the requisite MMX or x86-SSE version for each instruction. Unless otherwise noted, the source operand of an MMX instruction can be a memory location or an MMX register. The destination operand must be an MMX register. When referencing a memory location, an MMX instruction can use any of the x86-32 addressing modes described in Chapter 1. Proper alignment of memory operands is not required but strongly recommended since multiple memory cycles may be required to read a value from an unaligned memory location.

■ **Caution** The MMX instructions do not update any of the status bits in the EFLAGS register. Software routines must be used to detect, correct, or prevent potential error conditions such as arithmetic overflow or underflow.

Most MMX instruction mnemonics use the letters b (byte), w (word), d (doubleword), and q (quadword) to denote the width of the elements that will be processed.

Data Transfer

The data transfer group contains instructions that copy packed integer data values between MMX registers, general-purpose registers, and memory. Table 5-2 summarizes the data transfer instructions.

Table 5-2. *MMX Data Transfer Instructions*

Mnemonic	Description	Version
movd	Copies the low-order doubleword of an MMX register to a general-purpose register or a memory location. This instruction also can be used to copy the contents of a general-purpose register or memory location to the low-order doubleword of an MMX register.	MMX
movq	Copies the contents of an MMX register to another MMX register. This instruction also can be used to copy the contents of a memory location to an MMX register or vice versa.	MMX

Arithmetic

The arithmetic group contains instructions that perform basic arithmetic (addition, subtraction, and multiplication) on packed operands. This group also includes instructions that are used to perform high-level operations such as min/max, averaging, absolute values, and integer sign changes. All the arithmetic instructions support signed and unsigned integers unless otherwise noted. Table 5-3 lists the arithmetic group instructions.

Table 5-3. *MMX Arithmetic Instructions*

Mnemonic	Description	Version
paddb paddw paddd paddq	Performs packed integer addition using the specified operands.	MMX SSE2 (paddq)
paddsb paddsw	Performs packed signed integer addition using saturation.	MMX
paddusb paddusw	Performs packed unsigned integer addition using saturation.	MMX
psubb psubw psubd psubq	Performs packed integer subtraction using the specified operands. The source operand contains the subtrahends and the destination operands contain the minuends.	MMX SSE2 (psubq)
psubsb psubsw	Performs packed signed integer subtraction using saturation. The source operand contains the subtrahends and the destination operands contain the minuends.	MMX
psubusb psubusw	Performs packed unsigned integer subtraction using saturation. The source operand contains the subtrahends and the destination operands contain the minuends.	MMX
pmaddwd	Performs a packed signed-integer multiplication followed by a signed-integer addition that uses neighboring data elements within the products. This instruction can be used to calculate an integer dot product.	MMX
pmaddubsw	Performs a packed-integer multiplication using the signed-byte elements of the source operand and the unsigned-byte elements of the destination operand. The resultant signed-word values are added adjacently using saturation arithmetic and saved in the destination operand.	SSSE3
pmuludq	Multiplies the low-order doublewords of the source and destination operands and saves the quadword result in the destination operand.	SSE2
pmullw	Performs packed signed integer multiplication using word values. The low-order word of each doubleword product is saved to the destination operand.	MMX
pmulhw	Performs packed signed integer multiplication using word values. The high-order word of each doubleword product is saved to the destination operand.	MMX

(continued)

Table 5-3. (continued)

Mnemonic	Description	Version
<code>pmulhuw</code>	Performs packed unsigned integer multiplication using word values. The high-order word of each doubleword product is saved to the destination operand.	SSE
<code>pmulhrsw</code>	Performs packed signed integer multiplication using word values. The doubleword products are rounded to 18 bits, scaled to 16 bits, and saved to the destination operand.	SSSE3
<code>pavgb</code> <code>pavgw</code>	Computes the packed means of the specified operands using unsigned integer arithmetic.	SSE
<code>pmaxub</code>	Compares two packed unsigned-byte integer operands and saves the larger data element of each comparison.	SSE
<code>pminub</code>	Compares two packed unsigned-byte integer operands and saves the smaller data element of each comparison.	SSE
<code>pmaxsw</code>	Compares two packed signed-word integer operands and saves the larger data element of each comparison.	SSE
<code>pminsw</code>	Compares two packed signed-word integer operands and saves the smaller data element of each comparison.	SSE
<code>pabsb</code> <code>pabsw</code> <code>pabsd</code>	Computes the absolute value of each packed integer data element.	SSSE3
<code>psignb</code> <code>psignw</code> <code>psignd</code>	Negates, zeros, or keeps each signed-integer data element in the destination operand based on the sign of the matching data element in the source operand.	SSSE3
<code>phaddw</code> <code>phaddd</code>	Performs integer addition using adjacent data elements in the source and destination operands.	SSSE3
<code>phaddsw</code>	Performs signed-integer addition using adjacent data elements of the source and destination operands. The saturated results are saved to the destination operand.	SSSE3
<code>phsubw</code> <code>phsubd</code>	Performs integer subtraction using adjacent data elements in the source and destination operands.	SSSE3
<code>phsubsw</code>	Performs signed-integer subtraction using adjacent data elements of the source and destination operands. The saturated results are saved to the destination operand.	SSSE3

Comparison

The comparison group contains instructions that compare two packed operands element-by-element. The results of each comparison are saved to the corresponding position in the destination operand. Table 5-4 lists the comparison group instructions.

Table 5-4. *MMX Comparison Instructions*

Mnemonic	Description	Version
pcmpqtb pcmpqtw pcmpqtd	Compares two packed integer operands element-by-element for equality. If the source and destination data elements are equal, the corresponding data element in the destination operand is set to all ones; otherwise, the destination operand data element is set to all zeros.	MMX
pcmpgtb pcmpgtw pcmpgtd	Compares two packed signed-integer operands element-by-element for magnitude. If the destination operand data element is larger, the corresponding data element in the destination operand is set to all ones; otherwise, the destination operand data element is set to all zeros.	MMX

Conversion

The conversion group contains instructions that are used to pack the data elements of an operand. These instructions facilitate the conversion of integers from one type to another. Table 5-5 shows the conversion group instructions.

Table 5-5. *MMX Conversion Instructions*

Mnemonic	Description	Version
packsswb packssdw	Converts the word/doubleword packed integers in the source and destination operands to byte/word packed integers using signed saturation.	MMX
packuswb	Converts the word packed integers in the source and destination operands to byte packed integers using unsigned saturation.	MMX

Logical and Shift

The logical and shift group contains instructions that perform bitwise logical operations of operands. It also includes instructions that perform logical and arithmetic shifts using the individual data elements of a packed operand. Table 5-6 summarizes the logical and shift group instructions.

Table 5-6. *MMX Logical and Shift Instructions*

Mnemonic	Description	Version
<code>pand</code>	Performs a bitwise logical AND between the specified source and destination operands.	MMX
<code>pandn</code>	Performs a bitwise logical AND of the source operand and inverted destination operand.	MMX
<code>por</code>	Performs a bitwise logical inclusive OR between the specified source and destination operands.	MMX
<code>pxor</code>	Performs a bitwise logical exclusive OR between the specified source and destination operands.	MMX
<code>psllw</code> <code>pslld</code> <code>psllq</code>	Performs a logical left shift of each data element in the destination operand, shifting 0s into the low-order bits. The number of bits to shift is specified by the source operand and can be a memory location, an MMX register, or an immediate operand.	MMX
<code>pslrw</code> <code>pslrd</code> <code>pslrdq</code>	Performs a logical right shift of each data element in the destination operand, shifting 0s into the high-order bits. The number of bits to shift is specified by the source operand and can be a memory location, an MMX register, or an immediate operand.	MMX
<code>psraw</code> <code>psrad</code>	Performs an arithmetic right shift of each data element in the destination operand, shifting the original sign bit into the high-order bits. The number of bits to shift is specified by the source operand and can be a memory location, an MMX register, or an immediate operand.	MMX
<code>palignr</code>	Concatenates the destination and source operands to form a temporary value. This temporary value is byte-shifted right using a count that is specified by an immediate operand. The right-most quadword of the temporary value is saved to the destination operand.	SSSE3

Unpack and Shuffle

The unpack and shuffle group contains instructions that interleave (unpack) the data elements of a packed operand. It also contains instructions that can be used to reorder (shuffle) the data elements of a packed operand. These instructions are shown in Table 5-7.

Table 5-7. *MMX Unpack and Shuffle Instructions*

Mnemonic	Description	Version
punpckhbw punpckhwd punpckhdq	Unpacks and interleaves the high-order data elements of the source and destination operands. These instructions can be used to convert bytes to words, words to doublewords, or doublewords to quadwords.	MMX
punpcklbw punpcklwd punpckldq	Unpacks and interleaves the low-order data elements of the source and destination operands. These instructions can be used to convert bytes to words, words to doublewords, or doublewords to quadwords.	MMX
pshufb	Shuffles the bytes in the destination operand according to a control mask that is specified by the source operand. This instruction is used to reorder the bytes of a packed operand.	SSSE3
pshufw	Shuffles the words in the source operand according to a control mask that is specified using an immediate operand. This instruction is used to reorder the words of a packed operand.	SSE

Insertion and Extraction

The insertion and extraction group contains instructions that are used to insert or extract word values in an MMX register. Table 5-8 outlines the insertion and extraction instructions.

Table 5-8. *Insertion and Extraction Instructions*

Mnemonic	Description	Version
pinsrw	Copies the low-order word from a general-purpose register and inserts it into an MMX register. The element position in the MMX register is specified using an immediate operand.	SSE
pextrw	Extracts a word from an MMX register and copies it to the low-order word of a general-purpose register. The element position in the MMX register is specified using an immediate operand.	SSE

State and Cache Control

The state and cache control group contains instructions that inform the processor of MMX to x87 FPU state transitions. It also contains instructions that perform memory stores using non-temporal hints. A non-temporal hint notifies the processor that the data value can be written directly to memory without being stored in a memory cache. This can improve cache efficiency in applications such as audio and video encoding since cache clutter is eliminated. Table 5-9 reviews the state and cache control instructions.

Table 5-9. *MMX State and Cache Control Instructions*

Mnemonic	Description	Version
emms	Clears MMX state information by resetting the x87 FPU tag word to indicate that all x87 FPU registers are empty. This instruction must be used whenever a program transitions from executing MMX instructions to executing x87 FPU instructions.	MMX
movntq	Copies the contents of an MMX register to memory using a non-temporal hint.	SSE
maskmovq	Conditionally copies the bytes of an MMX register to memory using a non-temporal hint. A mask value, which is contained in a second MMX register, specifies the bytes that will be copied. Register EDI points to the destination memory location.	SSE

Summary

This chapter explored the essentials of MMX technology, including its register set, supported data types, and instruction set. You also studied some basic SIMD processing concepts and learned about the differences between wraparound and saturated integer arithmetic. Unlike other x86 computation resources such as the x87 FPU, it may not be completely obvious how a software developer can take advantage of MMX technology to solve real-world programming challenges. In Chapter 6 you'll examine a collection of sample code that demonstrates the benefits MMX technology and shows the proper use of its instruction set.



MMX Technology Programming

This chapter focuses on MMX programming. It begins by exploring MMX programming fundamentals. This is followed by an examination of some advanced MMX programming techniques that can accelerate the processing of integer arrays. All of the ensuing discussions and sample programs assume that you're familiar with the material in Chapter 5.

It was mentioned in Chapter 5 that MMX technology defines a basis for subsequent x86 SIMD extensions, including x86-SSE and x86-AVX. This means that you are strongly encouraged to peruse this chapter in order to acquire a thorough understanding of MMX programming and its associated instruction set, even if your ultimate goal is to develop code that targets one of the newer extensions. Understanding this chapter's material is also a must if you need to maintain an existing MMX code base.

MMX Programming Fundamentals

You'll begin your exploration of MMX technology by examining some sample programs that illustrate the basics of MMX programming. The first sample program that you'll study illustrates how to perform packed integer addition using both byte- and word-sized integers. The second sample program demonstrates use of the MMX shift instructions using packed operands. The final sample program shows how to perform packed signed integer multiplication. The primary purpose of the sample programs in this section is pedagogical. Later in this chapter, you'll learn how to code complete algorithms using the MMX instruction set.

Before you examine the sample programs, you'll review some data types that have been defined in order to simplify the MMX sample code. The header file `MiscDefs.h` includes several C++ typedef statements for common signed and unsigned integer types. These type definitions are shown in Listing 6-1 and are used by the sample code in this chapter and in subsequent chapters. The header file `MmxVal.h`, shown in Listing 6-2, declares a union named `MmxVal` that is used to exchange data between C++ and assembly language functions. Items declared in the union `MmxVal` match the packed data types that are supported by MMX. This union also includes several declarations for text string helper functions, which are used to format and display the contents of an `MmxVal` variable. The file `MmxVal.cpp` contains the definitions of the `ToString_` conversion functions. This file is not shown here but is included in the sample source code distribution file and is located in a subfolder named `CommonFiles`.

Listing 6-1. MiscDefs.h

```
#pragma once

// Signed integer typedefs
typedef __int8 Int8;
typedef __int16 Int16;
typedef __int32 Int32;
typedef __int64 Int64;

// Unsigned integer typedefs
typedef unsigned __int8 UInt8;
typedef unsigned __int16 UInt16;
typedef unsigned __int32 UInt32;
typedef unsigned __int64 UInt64;
```

Listing 6-2. MmxVal.h

```
#pragma once

#include "MiscDefs.h"

union MmxVal
{
    Int8 i8[8];
    Int16 i16[4];
    Int32 i32[2];
    Int64 i64;
    UInt8 u8[8];
    UInt16 u16[4];
    UInt32 u32[2];
    UInt64 u64;

    char* ToString_i8(char* s, size_t len);
    char* ToString_i16(char* s, size_t len);
    char* ToString_i32(char* s, size_t len);
    char* ToString_i64(char* s, size_t len);

    char* ToString_u8(char* s, size_t len);
    char* ToString_u16(char* s, size_t len);
    char* ToString_u32(char* s, size_t len);
    char* ToString_u64(char* s, size_t len);

    char* ToString_x8(char* s, size_t len);
    char* ToString_x16(char* s, size_t len);
    char* ToString_x32(char* s, size_t len);
    char* ToString_x64(char* s, size_t len);
};
```

Packed Integer Addition

The first sample program that you'll examine is called `MmxAddition`. This sample program illustrates the basics of SIMD addition using packed signed and unsigned integers. It also illustrates how to perform packed integer addition using both wraparound and saturated arithmetic. Besides demonstrating packed integer addition, `MmxAddition` exemplifies use of some common C++ and assembly language programming constructs, including unions and jump tables. The source code files for this sample program, `MmxAddition.cpp` and `MmxAddition_.asm`, are shown in Listings 6-3 and 6-4, respectively.

Listing 6-3. `MmxAddition.cpp`

```
#include "stdafx.h"
#include "MmxVal.h"

// The order of the name constants in the following enum must match
// the table that is defined in MmxAddition_.asm.
enum MmxAddOp : unsigned int
{
    paddb,      // packed byte addition with wraparound
    paddsb,     // packed byte addition with signed saturation
    paddusb,    // packed byte addition with unsigned saturation
    paddw,      // packed word addition with wraparound
    paddsw,     // packed word addition with signed saturation
    paddusw,    // packed word addition with unsigned saturation
    paddd      // packed doubleword addition with wraparound
};

extern "C" MmxVal MmxAdd_(MmxVal a, MmxVal b, MmxAddOp op);

void MmxAddBytes(void)
{
    MmxVal a, b, c;
    char buff [256];

    // Packed byte addition - signed integers
    a.i8[0] = 50;   b.i8[0] = 30;
    a.i8[1] = 80;   b.i8[1] = 64;
    a.i8[2] = -27;  b.i8[2] = -32;
    a.i8[3] = -70;  b.i8[3] = -80;

    a.i8[4] = -42;  b.i8[4] = 90;
    a.i8[5] = 60;   b.i8[5] = -85;
    a.i8[6] = 64;   b.i8[6] = 90;
    a.i8[7] = 100;  b.i8[7] = -30;
```



```

printf("\n\nPacked byte addition - signed integers\n");
printf("a: %s\n", a.ToString_i8(buff, sizeof(buff)));
printf("b: %s\n", b.ToString_i8(buff, sizeof(buff)));

c = MmxAdd_(a, b, MmxAddOp::paddb);
printf("\npaddb results\n");
printf("c: %s\n", c.ToString_i8(buff, sizeof(buff)));

c = MmxAdd_(a, b, MmxAddOp::paddsb);
printf("\npaddsb results\n");
printf("c: %s\n", c.ToString_i8(buff, sizeof(buff)));

// Packed byte addition - unsigned integers
a.u8[0] = 50; b.u8[0] = 30;
a.u8[1] = 80; b.u8[1] = 64;
a.u8[2] = 132; b.u8[2] = 130;
a.u8[3] = 200; b.u8[3] = 180;

a.u8[4] = 42; b.u8[4] = 90;
a.u8[5] = 60; b.u8[5] = 85;
a.u8[6] = 140; b.u8[6] = 160;
a.u8[7] = 10; b.u8[7] = 14;

printf("\n\nPacked byte addition - unsigned integers\n");
printf("a: %s\n", a.ToString_u8(buff, sizeof(buff)));
printf("b: %s\n", b.ToString_u8(buff, sizeof(buff)));

c = MmxAdd_(a, b, MmxAddOp::paddb);
printf("\npaddb results\n");
printf("c: %s\n", c.ToString_u8(buff, sizeof(buff)));

c = MmxAdd_(a, b, MmxAddOp::paddusb);
printf("\npaddusb results\n");
printf("c: %s\n", c.ToString_u8(buff, sizeof(buff)));
}

void MmxAddWords(void)
{
    MmxVal a, b, c;
    char buff [256];

    // Packed word addition - signed integers
    a.i16[0] = 550;    b.i16[0] = 830;
    a.i16[1] = 30000; b.i16[1] =5000;
    a.i16[2] = -270;  b.i16[2] = -320;
    a.i16[3] = -7000; b.i16[3] = -32000;

```

```

printf("\n\nPacked word addition - signed integers\n");
printf("a: %s\n", a.ToString_i16(buff, sizeof(buff)));
printf("b: %s\n", b.ToString_i16(buff, sizeof(buff)));

c = MmxAdd_(a, b, MmxAddOp::paddw);
printf("\npaddw results\n");
printf("c: %s\n", c.ToString_i16(buff, sizeof(buff)));

c = MmxAdd_(a, b, MmxAddOp::paddsw);
printf("\npaddsw results\n");
printf("c: %s\n", c.ToString_i16(buff, sizeof(buff)));

// Packed word addition - unsigned integers
a.u16[0] = 50;    b.u16[0] = 30;
a.u16[1] = 48000; b.u16[1] = 20000;
a.u16[2] = 132;  b.u16[2] = 130;
a.u16[3] = 10000; b.u16[3] = 60000;

printf("\n\nPacked word addition - unsigned integers\n");
printf("a: %s\n", a.ToString_u16(buff, sizeof(buff)));
printf("b: %s\n", b.ToString_u16(buff, sizeof(buff)));

c = MmxAdd_(a, b, MmxAddOp::paddw);
printf("\npaddw results\n");
printf("c: %s\n", c.ToString_u16(buff, sizeof(buff)));

c = MmxAdd_(a, b, MmxAddOp::paddusw);
printf("\npaddusw results\n");
printf("c: %s\n", c.ToString_u16(buff, sizeof(buff)));
}

int _tmain(int argc, _TCHAR* argv[])
{
    MmxAddBytes();
    MmxAddWords();
    return 0;
}

```

Listing 6-4. MmxAddition_.asm

```

.model flat,c
.code

; extern "C" MmxVal MmxAdd_(MmxVal a, MmxVal b, MmxAddOp add_op);
;
; Description: The following function demonstrates use of the

```

```

;           padd* instructions.
;
; Returns:   Register pair edx:eax contains the calculated result.

MmxAdd_     proc
            push ebp
            mov  ebp,esp

; Make sure 'add_op' is valid
            mov  eax,[ebp+24]           ;load 'add_op'
            cmp  eax,AddOpTableCount  ;compare to table count
            jae  BadAddOp             ;jump if 'add_op' is invalid

; Load parameters and execute specified instruction
            movq mm0,[ebp+8]           ;load 'a'
            movq mm1,[ebp+16]         ;load 'b'
            jmp  [AddOpTable+eax*4]    ;jump to specified 'add_op'

MmxPaddb:   paddb mm0,mm1             ;packed byte addition using
            jmp  SaveResult           ;wraparound

MmxPaddsb:  paddsb mm0,mm1           ;packed byte addition using
            jmp  SaveResult           ;signed saturation

MmxPaddusb: paddusb mm0,mm1          ;packed byte addition using
            jmp  SaveResult           ;unsigned saturation

MmxPaddw:   paddw mm0,mm1            ;packed word addition using
            jmp  SaveResult           ;wraparound

MmxPaddsw:  paddsw mm0,mm1           ;packed word addition using
            jmp  SaveResult           ;signed saturation

MmxPaddusw: paddusw mm0,mm1          ;packed word addition using
            jmp  SaveResult           ;unsigned saturation

MmxPaddd:   paddd mm0,mm1            ;packed dword addition using
            jmp  SaveResult           ;wraparound

BadAddOp:   pxor mm0,mm0             ;return 0 if 'add_op' is bad

; Move final result into edx:eax
SaveResult: movd eax,mm0              ;eax = low dword of mm0
            pshufw mm2,mm0,01001110b ;swap high & low dwords
            movd edx,mm2              ;edx:eax = final result

```

```

emms                                ;clear MMX state
pop ebp
ret

```

; The order of the labels in the following table must match
; the enum that is defined in MmxAddition.cpp.

```

    align 4
AddOpTable:
    dword MmxPaddb, MmxPaddsb, MmxPaddusb
    dword MmxPaddw, MmxPaddsw, MmxPaddusw, MmxPaddd
AddOpTableCount equ ($ - AddOpTable) / size dword

MmxAdd_ endp
end

```

Near the top of `MmxAddition.cpp` (Listing 6-3) is a C++ enumeration named `MmxAddOp`, which defines a set of enumerators that specify the type of packed addition to perform. In this example, the C++ compiler assigns the enumerators consecutive unsigned integer values starting with 0. The order of these enumerators is important and must match the jump table that is defined in `MmxAddition.asm` (Listing 6-4). You'll review the jump table ordering requirement in more depth later in this section. Following the definition of `MmxAddOp` is a declaration for the assembly language function `MmxAdd_`. The `MmxVal` parameters `a` and `b` represent the two packed operands that will be added. The `MmxAddOp` parameter `add_op` specifies the type of packed addition to perform while packed sum is returned as an `MmxVal`.

The source code file `MmxAddition.cpp` contains two principal functions: `MmxAddBytes` and `MmxAddWords`. These functions demonstrate MMX addition using packed byte and packed word operands. The function `MmxAddBytes` starts by initializing two `MmxVal` variables using 8-bit signed integer values. The x86 assembly language function `MmxAdd_` is then called twice to perform packed integer addition using both wraparound and saturated arithmetic. Following each call to `MmxAdd_`, the results are displayed on the screen. A similar sequence of C++ code is then used to carry out packed addition for 8-bit unsigned integers. The C++ function `MmxAddWords` follows the same pattern for 16-bit signed and unsigned integers.

Let's now take a look at the assembly language file `MmxAddition.asm` (Listing 6-4). Toward the bottom of this file is the previously mentioned assembly language jump table. The table named `AddOpTable` contains a list of assembly language labels that are defined in the function `MmxAdd_`. The target of each label contains a different MMX add instruction. The mechanics of jump table use is described shortly. The symbol `AddOpTableCount` defines the number of items in the jump table and is used to validate the function argument `add_op`. The `align 4` statement instructs the assembler to locate the table `AddOpTable` on a doubleword boundary in order to avoid unaligned memory accesses. Also note that the jump table is defined between the `proc` and `endp` statements. This means that storage for the table is allocated in a code block. Clearly, the jump table does not contain executable instructions, which explains why it is positioned after the `ret` instruction. This also implies that the jump table is read-only; the processor will generate an exception on any write attempt to the table.

Following its function prolog, function `MmxAdd_` loads the value of `add_op` into register `EAX`. A `mov eax, [ebp+24]` instruction is used to load `add_op` since the `MmxVal` arguments `a` and `b` are passed by value and each one requires eight bytes of stack space. A `cmp` instruction followed by a `jae` conditional jump instruction is then used to validate the value of `add_op`.

Subsequent to the validation of `add_op`, the function `MmxAdd_` loads argument `a` into register `MM0` using a `movq mm0, [ebp+8]` (Move Quadword) instruction. A second `movq` instruction is used to load argument `b` into `MM1`. The next instruction, `jmp [AddOpTable+eax*4]`, performs an indirect jump to the specified MMX add instruction. During execution of this instruction, the processor loads register `EIP` with the contents of the memory location that is specified by the instruction operand. In the current sample program, the processor reads the new `EIP` value from the memory location `[AddOpTable+eax*4]` (recall that register `EAX` contains `add_op`). This causes the processor to execute one of the MMX add instructions since the all of the label values in `AddOpTable` correspond to a `padd` instruction.

Each MMX add instruction sums the contents of `MM0` and `MM1` using the required packed element size and either wraparound or saturated arithmetic. Following each MMX addition, an unconditional jump is performed to a common block of code that saves the computed result. Note that if an invalid value for `add_op` was detected, a `pxor mm0, mm0` (Logical Exclusive OR) instruction is executed and it sets register `MM0` to all zeros.

The computed packed sum is saved near the label `SaveResult`. This warrants a closer look. The Visual C++ calling convention uses register pair `EDX:EAX` for 64-bit return values, which means that the contents of `MM0` must be copied to this register pair. The instruction `movd eax, mm0` (Move Doubleword) copies the low-order doubleword of `MM0` into `EAX`. Somewhat surprisingly, there is no MMX instruction that copies the high-order doubleword of an MMX register into a general-purpose register. In order to get around this limitation, a `pshufw mm2, mm0, 01001110b` (Shuffle Packed Words) instruction is used to swap the high and low doublewords of `MM0`. This instruction uses an 8-bit immediate operand to specify a word shuffle (or ordering) pattern. Reading this pattern value from right to left, each two-bit field represents a word location in the destination operand (i.e. bits 0-1 = word 0, bits 2-3 = word 1, etc.). The value of each two-bit field denotes the source operand word that gets copied to the designated destination operand word, as illustrated in Figure 6-1. Following the high-low doubleword swap, a `movd edx, mm2` instruction loads register `EDX` with the correct return value.

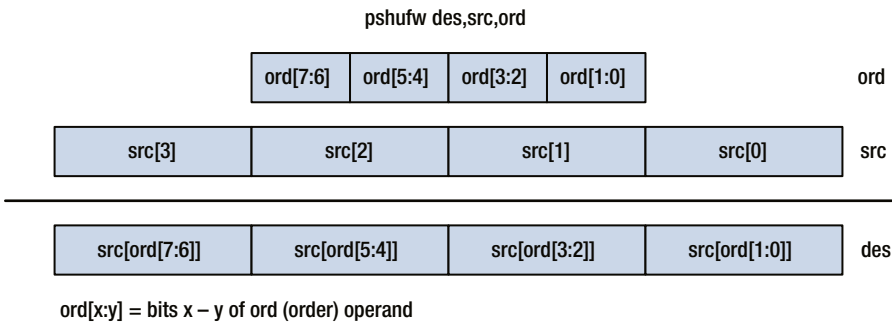

Figure 6-1. Operation of the `pshufw` instruction

The final instruction before the function epilog is `emms` (Empty MMX Technology State). As discussed in Chapter 5, the `emms` instruction *must* be used to reinstate the x87 FPU to normal floating-point operations following the execution of any MMX instruction. If an x87 FPU instruction is executed following an MMX instruction without an intervening `emms`, the x87 FPU may generate an exception or produce an invalid result.

Output 6-1 shows the results of the sample program `MmxAddition`. The test cases illustrate various combinations of signed and unsigned integers using both wraparound and saturated addition. In the first test case, byte integers are added. Note the difference when the values 80 and 64 are summed using wraparound (`paddb` results) and saturated addition (`paddsb` results); the former produces a result of -112 (an overflow), while the latter yields 127. At the other end of the range scale, adding -70 and -80 generates 106 (another overflow) and -128 when using wraparound and saturated addition, respectively. Output 6-1 also illustrates variations between wraparound and saturated addition using unsigned byte integers, signed word integers, and unsigned word integers.

Output 6-1. Sample Program `MmxAddition`

```
Packed byte addition - signed integers
a:  50  80 -27 -70 -42  60  64 100
b:  30  64 -32 -80  90 -85  90 -30

paddb results
c:  80 -112 -59 106  48 -25 -102  70

paddsb results
c:  80 127 -59 -128  48 -25 127  70

Packed byte addition - unsigned integers
a:  50  80 132 200  42  60 140  10
b:  30  64 130 180  90  85 160  14

paddb results
c:  80 144  6 124 132 145  44  24

paddusb results
c:  80 144 255 255 132 145 255  24

Packed word addition - signed integers
a:    550  30000  -270  -7000
b:    830   5000  -320  -32000

paddw results
c:    1380 -30536  -590  26536

paddsw results
c:    1380 32767  -590  -32768
```

Packed word addition - unsigned integers

```
a:      50   48000   132   10000
b:      30   20000   130   60000
```

paddw results

```
c:      80   2464   262   4464
```

paddusw results

```
c:      80   65535  262   65535
```

Packed Integer Shifts

The next sample program that you'll examine is called `MmxShift` and it demonstrates the use of the MMX shift instructions. Listings 6-5 and 6-6 contain the source code files `MmxShift.cpp` and `MmxShift_.asm`, respectively. Since the logical organization of `MmxShift` is very similar to the sample program `MmxAddition`, the comments that follow are succinct.

Listing 6-5. `MmxShift.cpp`

```
#include "stdafx.h"
#include "MmxVal.h"

// The order of the name constants in the following enum must
// correspond to the table that is defined in MmxShift_.asm.

enum MmxShiftOp : unsigned int
{
    psllw,    // shift left logical word
    psrlw,    // shift right logical word
    psraw,    // shift right arithmetic word
    psllw,    // shift left logical dword
    psrlw,    // shift right logical dword
    psrad,    // shift right arithmetic dword
};

extern "C" bool MmxShift_(MmxVal a, MmxShiftOp shift_op, int count, MmxVal*←
b);

void MmxShiftWords(void)
{
    MmxVal a, b;
    int count;
    char buff[256];

    a.u16[0] = 0x1234;
    a.u16[1] = 0xFF00;
```

```

a.u16[2] = 0x00CC;
a.u16[3] = 0x8080;
count = 2;

MmxShift_(a, MmxShiftOp::psllw, count, &b);
printf("\nResults for psllw - count = %d\n", count);
printf("a: %s\n", a.ToString_x16(buff, sizeof(buff)));
printf("b: %s\n", b.ToString_x16(buff, sizeof(buff)));

MmxShift_(a, MmxShiftOp::psrlw, count, &b);
printf("\nResults for psrlw - count = %d\n", count);
printf("a: %s\n", a.ToString_x16(buff, sizeof(buff)));
printf("b: %s\n", b.ToString_x16(buff, sizeof(buff)));

MmxShift_(a, MmxShiftOp::psraw, count, &b);
printf("\nResults for psraw - count = %d\n", count);
printf("a: %s\n", a.ToString_x16(buff, sizeof(buff)));
printf("b: %s\n", b.ToString_x16(buff, sizeof(buff)));
}

void MmxShiftDwords(void)
{
    MmxVal a, b;
    int count;
    char buff[256];

    a.u32[0] = 0x00010001;
    a.u32[1] = 0x80008000;
    count = 3;

    MmxShift_(a, MmxShiftOp::pslld, count, &b);
    printf("\nResults for pslld - count = %d\n", count);
    printf("a: %s\n", a.ToString_x32(buff, sizeof(buff)));
    printf("b: %s\n", b.ToString_x32(buff, sizeof(buff)));

    MmxShift_(a, MmxShiftOp::psrld, count, &b);
    printf("\nResults for psrld - count = %d\n", count);
    printf("a: %s\n", a.ToString_x32(buff, sizeof(buff)));
    printf("b: %s\n", b.ToString_x32(buff, sizeof(buff)));

    MmxShift_(a, MmxShiftOp::psrad, count, &b);
    printf("\nResults for psrad - count = %d\n", count);
    printf("a: %s\n", a.ToString_x32(buff, sizeof(buff)));
    printf("b: %s\n", b.ToString_x32(buff, sizeof(buff)));
}

```



```

int _tmain(int argc, _TCHAR* argv[])
{
    MmxShiftWords();
    MmxShiftDwords();
    return 0;
}

```

Listing 6-6. MmxShift.asm

```

        .model flat,c
        .code

; extern "C" bool MmxShift_(MmxVal a, MmxShiftOp shift_op, int count,
MmxVal* b);
;
; Description: The following function demonstrates use of various MMX
;              shift instructions.
;
; Returns:     0 = invalid 'shift_op' argument
;              1 = success

MmxShift_ proc
    push ebp
    mov ebp,esp

; Make sure 'shift_op' is valid
    xor eax,eax                    ;set error code
    mov edx,[ebp+16]               ;load 'shift_op'
    cmp edx,ShiftOpTableCount     ;compare against table count
    jae BadShiftOp                ;jump if 'shift_op' invalid

; Jump to the specfied shift operation
    mov eax,1                      ;set success return code
    movq mm0,[ebp+8]              ;load 'a'
    movd mm1,dword ptr [ebp+20]   ;load 'count' into low dword
    jmp [ShiftOpTable+edx*4]

MmxPsllw: psllw mm0,mm1           ;shift left logical word
    jmp SaveResult

MmxPsrlw: psrlw mm0,mm1           ;shift right logical word
    jmp SaveResult

MmxPsraw: psraw mm0,mm1          ;shift right arithmetic word
    jmp SaveResult

MmxPsllw: psllw mm0,mm1          ;shift left logical word
    jmp SaveResult

```

```

MmxPsrlld:  psrld mm0,mm1          ;shift right logical dword
            jmp SaveResult

MmxPsrad:   psrad mm0,mm1        ;shift right arithmetic dword
            jmp SaveResult

BadShiftOp: pxor mm0,mm0         ;use 0 if 'shift_op' is bad

SaveResult: mov edx,[ebp+24]      ;edx = ptr to 'b'
            movq [edx],mm0       ;save shift result
            emms                 ;clear MMX state

            pop ebp
            ret

```

; The order of the labels in the following table must correspond
; to the enum that is defined in MmxShift.cpp.

```

        align 4
ShiftOpTable:
        dword MmxPsllw, MmxPsrlw, MmxPsraw
        dword MmxPsllq, MmxPsrlq, MmxPsraq
ShiftOpTableCount equ ($ - ShiftOpTable) / size dword

MmxShift_ endp
end

```

Toward the top of file `MmxShift.cpp` (Listing 6-5), a C++ enumeration named `ShiftOp` defines enumerators for the various MMX shift operations. Next is a declaration statement for the x86 assembly language function `MmxShift_`. The prototype for this function differs slightly from `MmxAdd_`. `MmxShift_` saves its result to a caller-provided memory location instead of returning an `MmxVal`.

Following its prolog, the assembly language function `MmxShift_` (Listing 6-6) validates the value of argument `shift_op`. Next a `movq mm0,[ebp+8]` instruction loads the value of `a` into MMX register `MM0`. This is followed by a `movd mm1,dword ptr [ebp+20]` that loads the bit-shift count into the low-order doubleword of `MM1`. This count value specifies the number of bits that each word or doubleword element in `a` will be shifted (MMX instruction shift counts can also be specified using an immediate operand). The `jmp [ShiftOpTable+edx*4]` instruction transfers program control to the specified MMX shift instruction. Following completion of the shift operation, the results are saved to the memory location specified by the caller. Note that it is not necessary to use a `pshufw` instruction to swap the high and low doublewords of the result since all 64 bits are saved directly to memory by the `movq` instruction. Output 6-2 shows the results of the sample program `MmxShift`.

Output 6-2. Sample Program MmxShift

Results for psllw - count = 2

a: 1234 FF00 00CC 8080

b: 48D0 FC00 0330 0200

Results for psrlw - count = 2

a: 1234 FF00 00CC 8080

b: 048D 3FC0 0033 2020

Results for psraw - count = 2

a: 1234 FF00 00CC 8080

b: 048D FFC0 0033 E020

Results for pslld - count = 3

a: 00010001 80008000

b: 00080008 00040000

Results for psrld - count = 3

a: 00010001 80008000

b: 00002000 10001000

Results for psrad - count = 3

a: 00010001 80008000

b: 00002000 F0001000

Packed Integer Multiplication

The final sample program of this section is called `MmxMultiplication` and it demonstrates how to perform signed integer multiplication using packed word operands. Listings 6-7 and 6-8 contain the source code for the files `MmxMultiplication.cpp` and `MmxMultiplication.asm`, respectively. For the ensuing discussion, it's helpful to recall that the multiplicative product of two-word (16-bit) integers is always a doubleword (32-bit) integer.

Listing 6-7. `MmxMultiplication.cpp`

```
#include "stdafx.h"
#include "MmxVal.h"

extern "C" void MmxMulSignedWord_(MmxVal a, MmxVal b, MmxVal* prod_lo,
MmxVal* prod_hi);

int _tmain(int argc, _TCHAR* argv[])
{
    MmxVal a, b, prod_lo, prod_hi;
    char buff[256];
```

```

a.i16[0] = 10;      b.i16[0] = 2000;
a.i16[1] = 30;      b.i16[1] = -4000;
a.i16[2] = -50;     b.i16[2] = 6000;
a.i16[3] = -70;     b.i16[3] = -8000;

MmxMulSignedWord_(a, b, &prod_lo, &prod_hi);

printf("\nResults for MmxMulSignedWord_\n");
printf("a: %s\n", a.ToString_i16(buff, sizeof(buff)));
printf("b: %s\n\n", b.ToString_i16(buff, sizeof(buff)));
printf("prod_lo: %s\n", prod_lo.ToString_i32(buff, sizeof(buff)));
printf("prod_hi: %s\n", prod_hi.ToString_i32(buff, sizeof(buff)));

return 0;
}

```

Listing 6-8. MmxMultiplication_.asm

```

.model flat,c
.code

; extern "C" void MmxMulSignedWord_(MmxVal a, MmxVal b, MmxVal* prod_lo, ←
MmxVal* prod_hi)
;
; Description: The following function performs a SIMD multiplication of
; two packed signed word operands. The resultant doubleword
; products are saved to the specified memory locations.

MmxMulSignedWord_ proc
    push ebp
    mov ebp,esp

; Load arguments 'a' and 'b'
    movq mm0,[ebp+8]           ;mm0 = 'a'
    movq mm1,[ebp+16]        ;mm1 = 'b'

; Perform packed signed integer word multiplication
    movq mm2,mm0             ;mm2 = 'a'
    pmullw mm0,mm1          ;mm0 = product low result
    pmulhw mm1,mm2          ;mm1 = product high result

; Unpack and interleave low and high products to form
; final packed doubleword products
    movq mm2,mm0             ;mm2 = product low result
    punpcklwd mm0,mm1        ;mm0 = low dword products
    punpckhwd mm2,mm1        ;mm2 = high dword products

```

```

; Save the packed doubleword results
mov eax,[ebp+24]           ;eax = pointer to 'prod_lo'
mov edx,[ebp+28]           ;edx = pointer to 'prod_hi'
movq [eax],mm0             ;save low dword products
movq [edx],mm2             ;save high dword products

pop ebp
ret
MmxMulSignedWord_ endp
end

```

Let's begin by examining the assembly language function `MmxMulSignedWord_` (Listing 6-8). This function multiplies two packed signed word operands and saves the resultant packed doubleword products to memory. Immediately following the function prolog, the `MmxVal` arguments `a` and `b` are loaded into registers `MM0` and `MM1`, respectively. The instruction `pmullw mm0,mm1` (Multiply Packed Integers and Store Low Result) multiplies the two packed signed word integers and stores the low-order 16 bits of each product to register `MM0`. Similarly, the instruction `pmulhw mm1,mm2` (Multiply Packed Integers and Store High Result) multiplies and stores the high-order 16 bits of each product to register `MM1` (note that `MM0` was copied to `MM2` prior to execution of the `pmullw` instruction). Figure 6-2 elucidates the operation of the `pmullw` and `pmulhw` instructions.

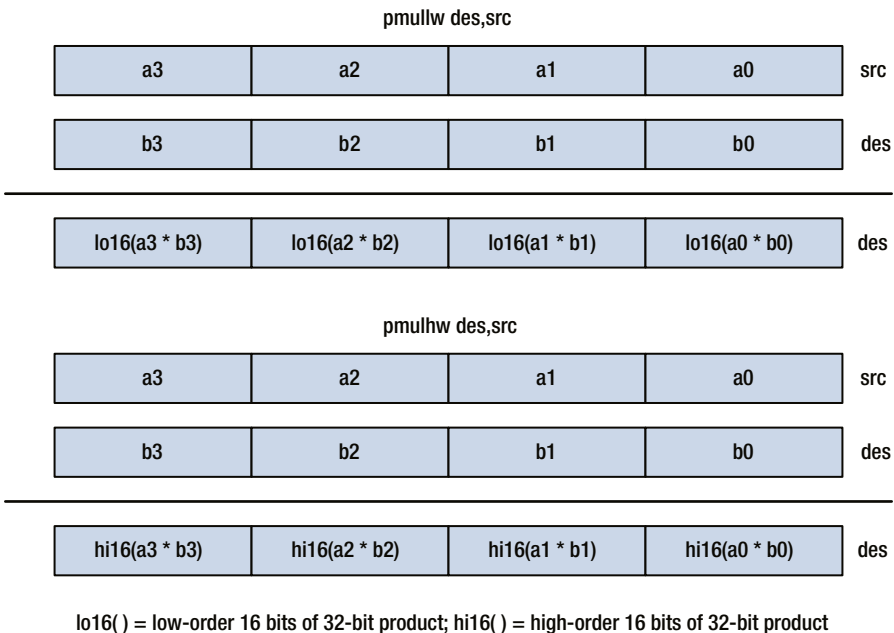

Figure 6-2. Operation of the `pmullw` and `pmulhw` instructions

Following calculation of the products, the high and low results need to be combined in order to create the final packed signed doublewords products. This is accomplished using the `punpcklwd` (Unpack Low Data, Word to Doubleword) and `punpckhwd` (Unpack High Data, Word to Doubleword) instructions. These instructions unpack and interleave the elements of a packed word value, as illustrated in Figure 6-3. The MMX instruction set also includes similar instructions that unpack and interleave the elements of packed byte and packed doubleword values. You'll see an example of the former later in this chapter.

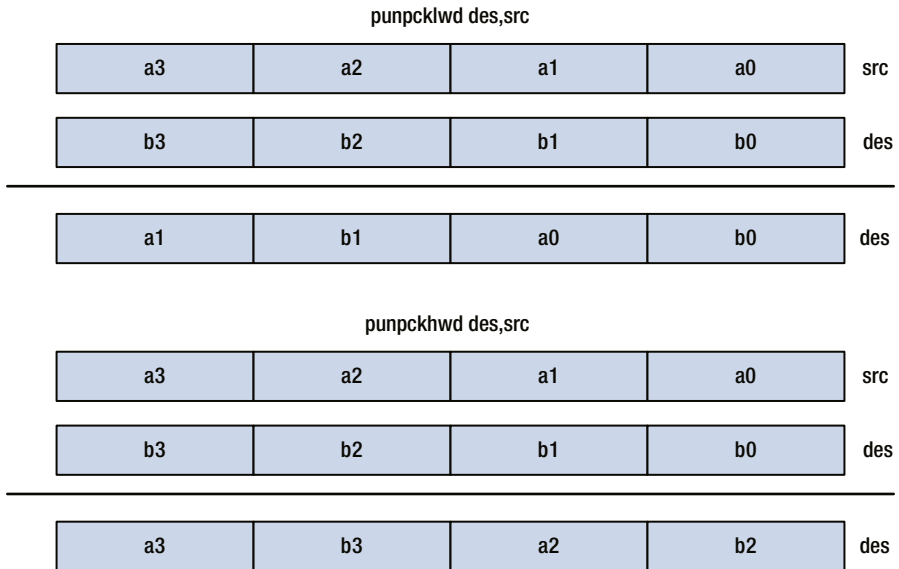

Figure 6-3. Operation of the `punpcklwd` and `punpckhwd` instructions

The final few instructions of `MmxMulSignedWord_` save the packed doubleword data values in MM0 and MM2 to the memory locations specified by the caller. The file `MmxMultiplication.cpp` (Listing-6-7) contains some straightforward code that sets up a test case, calls `MmxMulSignedWord_`, and prints the result. Note that the display text strings for `prod_lo` and `prod_hi` are formatted using the member function `MmxVal::ToString_i32`, since both of these instances contain two doublewords. Output 6-3 shows the results of the sample program `MmxMultiplication`.

Output 6-3. Sample Program `MmxMultiplication`

```
Results for MmxMulSignedWord_
a:    10      30     -50     -70
b:   2000   -4000    6000   -8000

prod_lo:    20000    -120000
prod_hi:   -300000     560000
```

MMX Advanced Programming

The sample programs of the previous section were intended as an introduction to MMX programming. Each program included a simple x86 assembly language function that demonstrated the operation of several MMX instructions using instances of the union `MmxVal`. For some real-world application programs, it may be acceptable to create a small set of functions similar to the ones you've seen thus far. However, in order to fully exploit the benefits of the x86's SIMD architecture, you need to code functions that implement complete algorithms. That is the focus of this section.

The sample programs that follow illustrate the processing of 8-bit unsigned integer arrays using the MMX instruction set. In the first program, you'll learn how to determine the minimum and maximum value of an array. This sample program has a certain practicality to it since digital images often use arrays of 8-bit unsigned integers to represent images in memory and many image-processing algorithms need to determine the minimum (darkest) and maximum (lightest) pixels in an image. The second sample program illustrates how to calculate the mean value of an array. This is another example of a realistic algorithm that is directly relevant to the province of image processing.

You read in the book's Introduction that x86 assembly language can be used to accelerate the performance of certain algorithms, but you haven't seen any evidence thus far to support this claim. That will change in this section. In both sample programs, the key algorithms are coded using both C++ and x86 assembly language in order to facilitate quantitative timing measurements and comparisons. The specific details of these timing measurements are included as part of the discussions that follow.

Integer Array Processing

The sample program of this section is named `MmxCalcMinMax` and it computes the maximum and minimum values of an array of 8-bit unsigned integers. It also demonstrates some techniques that can be used to measure the performance of an x86 assembly language function. The source code files `MmxCalcMinMax.h`, `MmxCalcMinMax.cpp`, and `MmxCalcMinMax_.asm` are shown in Listings 6-9, 6-10, and 6-11, respectively.

Listing 6-9. `MmxCalcMinMax.h`

```
#pragma once

#include "MiscDefs.h"

// Functions defined in MmxCalcMinMax.cpp
extern bool MmxCalcMinMaxCpp(UInt8* x, int n, UInt8* x_min, UInt8* x_max);

// Functions defined in MmxCalcMinMaxTimed.cpp
extern void MmxCalcMinMaxTimed(void);

// Functions defined in MmxCalcMinMax_.asm
extern "C" bool MmxCalcMinMax_(UInt8* x, int n, UInt8* x_min, UInt8* x_max);
```

```
// Common constants
const int NUM_ELEMENTS = 0x800000;
const int SRAND_SEED = 14;
```

Listing 6-10. MmxCalcMinMax.cpp

```
#include "stdafx.h"
#include "MmxCalcMinMax.h"
#include <stdlib.h>

extern "C" int NMIN = 16;           // Minimum number of array elements

bool MmxCalcMinMaxCpp(UInt8* x, int n, UInt8* x_min, UInt8* x_max)
{
    if ((n < NMIN) || ((n & 0x0f) != 0))
        return false;

    UInt8 x_min_temp = 0xff;
    UInt8 x_max_temp = 0;

    for (int i = 0; i < n; i++)
    {
        UInt8 val = *x++;

        if (val < x_min_temp)
            x_min_temp = val;
        else if (val > x_max_temp)
            x_max_temp = val;
    }

    *x_min = x_min_temp;
    *x_max = x_max_temp;
    return true;
}

void MmxCalcMinMax()
{
    const int n = NUM_ELEMENTS;
    UInt8* x = new UInt8[n];

    // Initialize test array with known min and max values
    srand(SRAND_SEED);
    for (int i = 0; i < n; i++)
        x[i] = (UInt8)((rand() % 240) + 10);

    x[n / 4] = 4;
    x[n / 2] = 252;
```



```

    bool rc1, rc2;
    UInt8 x_min1 = 0, x_max1 = 0;
    UInt8 x_min2 = 0, x_max2 = 0;

    rc1 = MmxCalcMinMaxCpp(x, n, &x_min1, &x_max1);
    rc2 = MmxCalcMinMax_(x, n, &x_min2, &x_max2);

    printf("\nResults for MmxCalcMinMax()\n");
    printf("rc1: %d  x_min1: %3u  x_max1: %3u\n", rc1, x_min1, x_max1);
    printf("rc2: %d  x_min2: %3u  x_max2: %3u\n", rc2, x_min2, x_max2);
    delete[] x;
}

int _tmain(int argc, _TCHAR* argv[])
{
    MmxCalcMinMax();
    MmxCalcMinMaxTimed();
    return 0;
}

```

Listing 6-11. MmxCalcMinMax_.asm

```

        .model flat,c
        .const
StartMinVal qword 0fffffffffffffffh    ;Initial packed min value
StartMaxVal qword 0000000000000000h    ;Initial packed max value
        .code
        extern NMIN:dword                ;Minimum size of array

; extern "C" bool MmxCalcMinMax_(UInt8* x, int n, UInt8* x_min, UInt8*
x_max);
;
; Description: The following function calculates the minimum and
;              maximum values of an array of 8-bit unsigned integers.
;
; Returns:     0 = invalid 'n'
;              1 = success

MmxCalcMinMax_ proc
    push ebp
    mov ebp,esp

; Make sure 'n' is valid
    xor eax,eax                    ;set error return code
    mov ecx,[ebp+12]                ;ecx = 'n'
    cmp ecx,[NMIN]
    jl Done                          ;jump if n < NMIN

```

```

    test ecx,0fh
    jnz Done                                ;jump if n & 0x0f != 0

; Initialize
    shr ecx,4                               ;ecx = number of 16-byte blocks
    mov edx,[ebp+8]                          ;edx = pointer to 'x'
    movq mm4,[StartMinVal]
    movq mm6,mm4                            ;mm6:mm4 current min values
    movq mm5,[StartMaxVal]
    movq mm7,mm5                            ;mm7:mm5 current max values

; Scan array for min & max values
@@:   movq mm0,[edx]                         ;mm0 = packed 8 bytes
    movq mm1,[edx+8]                         ;mm1 = packed 8 bytes
    pminub mm6,mm0                           ;mm6 = updated min values
    pminub mm4,mm1                           ;mm4 = updated min values
    pmaxub mm7,mm0                           ;mm7 = updates max values
    pmaxub mm5,mm1                           ;mm5 = updates max values
    add edx,16                               ;set edx to next 16 byte block
    dec ecx
    jnz @B                                   ;jump if more data remains

; Determine final minimum value
    pminub mm6,mm4                           ;mm6[63:0] = final 8 min vals
    pshufw mm0,mm6,00001110b                ;mm0[31:0] = mm6[63:32]
    pminub mm6,mm0                           ;mm6[31:0] = final 4 min vals
    pshufw mm0,mm6,00000001b                ;mm0[15:0] = mm6[31:16]
    pminub mm6,mm0                           ;mm6[15:0] = final 2 min vals
    pextrw eax,mm6,0                         ;ax = final 2 min vals
    cmp al,ah
    jbe @F                                   ;jump if al <= ah
    mov al,ah                                ;al = final min value
@@:   mov edx,[ebp+16]
    mov [edx],al                             ;save final min value

; Determine final maximum value
    pmaxub mm7,mm5                           ;mm7[63:0] = final 8 max vals
    pshufw mm0,mm7,00001110b                ;mm0[31:0] = mm7[63:32]
    pmaxub mm7,mm0                           ;mm7[31:0] = final 4 max vals
    pshufw mm0,mm7,00000001b                ;mm0[15:0] = mm7[31:16]
    pmaxub mm7,mm0                           ;mm7[15:0] = final 2 max vals
    pextrw eax,mm7,0                         ;ax = final 2 max vals
    cmp al,ah
    jae @F                                   ;jump if al >=ah
    mov al,ah                                ;al = final max value
@@:   mov edx,[ebp+20]
    mov [edx],al                             ;save final max value

```

```

; Clear MMX state and set return code
    emms
    mov eax,1

Done:  pop ebp
       ret
MmxCalcMinMax_  endp
end

```

Near the top of the `MmxCalcMinMax.cpp` file (Listing 6-10) is a function named `MmxCalcMinMaxCpp`. This function is a C++ implementation of an algorithm that scans an array of 8-bit unsigned integers to find the smallest and largest values. Parameters for this function include a pointer to the array, the number of elements in the array, and pointers for the minimum and maximum values. The algorithm itself consists of a simple loop that tests each array element to see if it's smaller or larger than the current minimum or maximum values. One item to note in function `MmxCalcMinMaxCpp` is that the size of the array must be greater than or equal to 16 and evenly divisible by 16. There are two reasons for these restrictions. First, they simplify the code of the assembly language function that implements the same algorithm as `MmxCalcMinMaxCpp`. Second, they eliminate the need to add extra code to process partial pixel blocks, which ultimately improves performance.

The `MmxCalcMinMax.cpp` file also includes a function called `MmxCalcMinMax`, which initializes a test array, invokes the appropriate C++ and assembly language functions, and displays results. The test array is initialized using the standard library function `rand` except for two elements that help confirm the correctness of the algorithms. Function `MmxCalcMinMax` is called from `_tmain`. Also note that `_tmain` calls a function named `MmxCalcMinMaxTimed`, which contains code to measure the performance of both `MmxCalcMinMax` and `MmxCalcMinMax_`. I'll discuss this function later in this section.

The assembly language function `MmxCalcMinMax_` (Listing 6-11) implements the same algorithm as its C++ counterpart with one significant difference. It processes array elements using 8-byte packets, which is the maximum number of 8-bit integers that can be stored in an MMX register. The function `MmxCalcMinMax_` begins by ensuring that the size of argument `n` is valid.

Following validation of `n`, function `MmxCalcMinMax_` performs some basic initialization. A `shr ecx,4` instruction computes the number of 16-byte blocks in the array. The number of 16-byte blocks is calculated since the processing loop in `MmxCalcMinMax_` analyzes 16 bytes per iteration, which is slightly faster than analyzing 8 bytes per iteration. You'll learn why this is true in Chapter 21. After initialization of register `EDX` as a pointer to array `x`, register pairs `MM6:MM4` and `MM7:MM5` are primed to maintain the current minimum and maximum of the array. Note that unlike the C++ implementation of the algorithm, the assembly language version will track 16 minimum and maximum values simultaneously. Following completion of the processing loop, the algorithm will determine the final array minimum and maximum using the values in the aforementioned register pairs.

The processing loop of `MmxCalcMinMax_` is remarkably short. During each iteration, the instructions `movq mm0,[edx]` and `movq mm1,[edx+8]` load registers `MM0` and `MM1` with the next block of pixels. This block of pixels is then compared against the current minimums using two `pminub` (Minimum of Packed Unsigned Byte Integers) instructions. The `pminub` instruction performs an unsigned compare of matching elements in the

specified registers and saves the smaller values to the destination operand. The current maximum values are then updated in a similar manner using two consecutive `pmaxub` (Maximum of Packed Unsigned Byte Integers) instructions. Processing of the array continues until all elements have been examined. Subsequent to the completion of the processing loop, register pairs MM6:MM4 and MM7:MM5 contain the packed minimums and maximums, respectively.

Following the processing loop is a sequence of instructions that reduces the 16 values in MM6:MM4 to the final minimum value. This is achieved using a series of `pminub`, `pshufw`, and `pextrw` (Extract Word) instructions, as illustrated in Figure 6-4. A `pminub mm6,mm4` instruction reduces the packed minimums from 16 to 8 values, which means that they now fit in a single MMX register. Next, a `pshufw mm0,mm6,00001110b` instruction copies the upper four byte values in MM6 to the low-order positions of MM0. This is followed by the `pminub mm6,mm0` instruction, which reduces the number of minimum values from eight to four (the upper doublewords of mm6 and mm0 are don't-care values). Another `pshufw/pminub` instruction sequence reduces the number of minimum values to two. The final minimum value is determined as follows. First, a `pextrw eax,mm6,0` instruction copies the low-order word element of MM6 (specified by the immediate operand 0) to the low-order word of register EAX; the high-order word of EAX is set to zero. Following execution of this instruction, the two penultimate minimum values are stored in registers AH and AL. The final minimum value is determined using an x86 compare and conditional jump instruction.

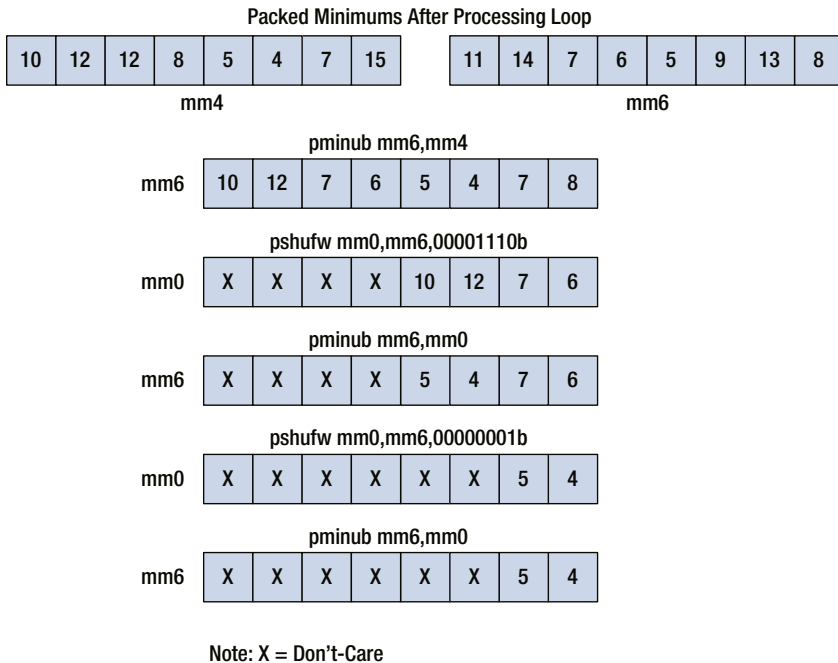

Figure 6-4. Reduction of packed minimum values. The data values in this figure illustrate operation of the MMX instruction sequence

Function `MmxCalcMinMax_` uses a similar sequence of instructions to compute the maximum value in the array. The only modifications are the use of a `pmaxub` instruction instead of `pminub` and a different conditional jump. Output 6-4 shows the results of the sample program `MmxCalcMinMax`.

Output 6-4. Sample Program `MmxCalcMinMax`

Results for `MmxCalcMinMax()`

```
rc1: 1  x_min1:  4  x_max1: 252
```

```
rc2: 1  x_min2:  4  x_max2: 252
```

Results for `MmxCalcMinMaxTimed()`

```
x_min1:  4  x_max1: 252
```

```
x_min2:  4  x_max2: 252
```

Benchmark times saved to file `__MmxCalcMinMaxTimed.csv`

Output 6-4 includes a reference to a CSV (comma-separated value) file that contains benchmark times. This file is created by the function `MmxCalcMinMaxTimed`, which measures the performance of the functions `MmxCalcMinMaxCpp` and `MmxCalcMinMax_`. Listing 6-12 shows the source code for the `MmxCalcMinMaxTimed.cpp` file.

Listing 6-12. `MmxCalcMinMaxedTimed.cpp`

```
#include "stdafx.h"
#include "MmxCalcMinMax.h"
#include "ThreadTimer.h"
#include <stdlib.h>

void MmxCalcMinMaxTimed(void)
{
    // Force current thread to execute on a single processor
    ThreadTimer::SetThreadAffinityMask();

    const int n = NUM_ELEMENTS;
    UInt8* x = new UInt8[n];

    // Initialize test array with known min and max values
    srand(SRAND_SEED);
    for (int i = 0; i < n; i++)
        x[i] = (UInt8)((rand() % 240) + 10);

    x[n / 4] = 4;
    x[n / 2] = 252;

    const int num_it = 100;
    const int num_alg = 2;
    const double et_scale = 1.0e6;
```

```

double et[num_it][num_alg];
Uint8 x_min1 = 0, x_max1 = 0;
Uint8 x_min2 = 0, x_max2 = 0;
ThreadTimer tt;

for (int i = 0; i < num_it; i++)
{
    tt.Start();
    MmxCalcMinMaxCpp(x, n, &x_min1, &x_max1);
    tt.Stop();
    et[i][0] = tt.GetElapsedTime() * et_scale;
}

for (int i = 0; i < num_it; i++)
{
    tt.Start();
    MmxCalcMinMax_(x, n, &x_min2, &x_max2);
    tt.Stop();
    et[i][1] = tt.GetElapsedTime() * et_scale;
}

const char* fn = "_MmxCalcMinMaxTimed.csv";
ThreadTimer::SaveElapsedTimeMatrix(fn, (double*)et, num_it, num_alg);

printf("\nResults for MmxCalcMinMaxTimed()\n");
printf("x_min1: %3u x_max1: %3d\n", x_min1, x_max1);
printf("x_min2: %3u x_max2: %3d\n", x_min2, x_max2);
printf("\nBenchmark times saved to file %s\n", fn);
delete[] x;
}

```

The function `MmxCalcMinMaxTimed` relies on a C++ class named `ThreadTimer` to measure how long a section of code takes to execute. This class uses a couple of Windows API functions, `QueryPerformanceCounter` and `QueryPerformanceFrequency`, to implement a simple software stopwatch. The member functions `ThreadTimer::Start` and `ThreadTimer::Stop` record the value of a system counter while `ThreadTimer::GetElapsedTime` computes the difference in seconds between the start and stop counters. Class `ThreadTimer` also includes several member functions that help manage process and thread affinity. These functions can be applied to select a specific execution CPU for a process or thread, which improves the accuracy of the timing measurements. The source code for class `ThreadTimer` is not shown here but included as part of the downloadable software package. Table 6-1 contains the mean execution times for the functions `MmxCalcMinMaxCpp` and `MmxCalcMinMax_` using several different processors.

Table 6-1. Mean Execution Times (in Microseconds) for `MmxCalcMinMax` Functions

CPU	<code>MmxCalcMinMaxCpp (C++)</code>	<code>MmxCalcMinMax_ (x86-32 MMX)</code>
Intel Core i7-4770	10813	364
Intel Core i7-4600U	12833	570
Intel Core i3-2310M	20980	950

As shown in Output 6-4, the file `__MmxCalcMinMaxTimed.csv` was generated by running the executable `MmxCalcMinMax.exe`. This EXE file was built using the Visual C++ Release Configuration option and the default settings for code optimization. All time measurements were made using ordinary desktop and notebook PCs running Windows 8.x or Windows 7 with Service Pack 1. No attempt was made to account for any hardware, software, operating system, or configuration differences between the PCs prior to running the sample program executable file.

The values shown in Table 6-1 were computed using the Excel spreadsheet function `TRIMMEAN(array, 0.10)` and the execution times in the CSV file. For sample program `MmxCalcMinMax`, the x86-32 MMX implementation of the min-max algorithm clearly outperforms the C++ version by a wide margin. I should mention that the performance gains observed in sample program `MmxCalcMinMax` are somewhat atypical. Nevertheless, it is not uncommon to achieve significant speed improvements using x86 assembly language, especially by algorithms that can exploit the SIMD parallelism of an x86 processor. You'll see additional examples of accelerated algorithmic performance throughout the remainder of this book.

Like automobile fuel economy estimates and smartphone battery run-time approximations, software performance benchmarking is not an exact science. Measurements must be made and results construed in a context that is appropriate for the specific benchmark and target execution environment. The methods used here to benchmark execution times are generally worthwhile, but results can vary between runs depending on the configuration of the test PC. When conducting performance benchmarking, I find that in most cases it is usually better to focus on the relative differences in execution times rather than on absolute measurements.

Using MMX and the x87 FPU

The final sample program of this chapter is called `MmxCalcMean` and it calculates the arithmetic mean of an array of 8-bit unsigned integers. The sample program `MmxCalcMean` also illustrates how to size-promote packed unsigned integers and use x87 FPU instructions in a function that includes MMX instructions. Listings 6-13, 6-14, and 6-15 contain the source code for the sample program.

Listing 6-13. MmxCalcMean.h

```
#pragma once

#include "MiscDefs.h"

// Functions defined in MmxCalcMean.cpp
extern bool MmxCalcMeanCpp(const Uint8* x, int n, Uint32* sum_x, double*←
mean);

// Functions defined in MmxCalcMeanTimed.cpp
extern void MmxCalcMeanTimed(void);

// Functions defined in MmxCalcMean_.asm
extern "C" bool MmxCalcMean_(const Uint8* x, int n, Uint32* sum_x, double*←
mean);

// Common constants
const int NUM_ELEMENTS = 0x800000;
const int SRAND_SEED = 23;
```

Listing 6-14. MmxCalcMean.cpp

```
#include "stdafx.h"
#include "MmxCalcMean.h"
#include <stdlib.h>

extern "C" int NMIN = 16;           // Minimum number of elements
extern "C" int NMAX = 16777216;    // Maximum number of elements

bool MmxCalcMeanCpp(const Uint8* x, int n, Uint32* sum_x, double* mean_x)
{
    if ((n < NMIN) || (n > NMAX) || ((n & 0x0f) != 0))
        return false;

    Uint32 sum_x_temp = 0;
    for (int i = 0; i < n; i++)
        sum_x_temp += x[i];

    *sum_x = sum_x_temp;
    *mean_x = (double)sum_x_temp / n;
    return true;
}

void MmxCalcMean()
{
    const int n = NUM_ELEMENTS;
    Uint8* x = new Uint8[n];
```



```

    srand(SRAND_SEED);
    for (int i = 0; i < n; i++)
        x[i] = rand() % 256;

    bool rc1, rc2;
    UInt32 sum_x1 = 0, sum_x2 = 0;
    double mean_x1 = 0, mean_x2 = 0;

    rc1 = MmxCalcMeanCpp(x, n, &sum_x1, &mean_x1);
    rc2 = MmxCalcMean_(x, n, &sum_x2, &mean_x2);

    printf("\nResults for MmxCalcMean()\n");
    printf("rc1: %d sum_x1: %u mean_x1: %12.6lf\n", rc1, sum_x1, mean_x1);
    printf("rc2: %d sum_x2: %u mean_x2: %12.6lf\n", rc2, sum_x2, mean_x2);
    delete[] x;
}

int _tmain(int argc, _TCHAR* argv[])
{
    MmxCalcMean();
    MmxCalcMeanTimed();
    return 0;
}

```

Listing 6-15. MmxCalcMean_.asm

```

.model flat,c
.code
extern NMIN:dword, NMAX:dword          ;min and max array sizes

; extern "C" bool MmxCalcMean_(const UInt8* x, int n, UInt32* sum_x, double* ←
mean);
;
; Description: This function calculates the sum and mean of an array
;              containing 8-bit unsigned integers.
;
; Returns      0 = invalid 'n'
;              1 = success

MmxCalcMean_ proc
    push ebp
    mov ebp,esp
    sub esp,8                          ;local storage for x87 transfer

; Verify n is valid
    xor eax,eax                        ;set error return code
    mov ecx,[ebp+12]
    cmp ecx,[NMIN]

```

```

    jl Done                    ;jump if n < NMIN
    cmp ecx,[NMAX]            ;jump if n > NMAX
    jg Done
    test ecx,0fh              ;jump if n % 16 != 0
    jnz Done                  ;number of 16-byte blocks
    shr ecx,4

; Perform required initializations
    mov eax,[ebp+8]           ;pointer to array 'x'
    pxor mm4,mm4              ;mm5:mm4 = packed sum (4 dwords)
    pxor mm5,mm5              ;mm7 = packed zero for promotions
    pxor mm7,mm7

; Load the next block of 16 array values
@@:    movq mm0,[eax]
        movq mm1,[eax+8]      ;mm1:mm0 = 16 byte block

; Promote array values from bytes to words, then sum the words
    movq mm2,mm0
    movq mm3,mm1
    punpcklbw mm0,mm7         ;mm0 = 4 words
    punpcklbw mm1,mm7         ;mm1 = 4 words
    punpckhbw mm2,mm7         ;mm2 = 4 words
    punpckhbw mm3,mm7         ;mm3 = 4 words
    paddw mm0,mm2
    paddw mm1,mm3
    paddw mm0,mm1            ;mm0 = pack sums (4 words)

; Promote packed sums to dwords, then update dword sums in mm5:mm4
    movq mm1,mm0
    punpcklwd mm0,mm7         ;mm0 = packed sums (2 dwords)
    punpckhwd mm1,mm7         ;mm1 = packed sums (2 dwords)
    padd  mm4,mm0
    padd  mm5,mm1            ;mm5:mm4 = packed sums (4 dwords)

    add eax,16                ;eax = next 16 byte block
    dec ecx
    jnz @B                    ;repeat loop if not done

; Compute final sum_x
    padd  mm5,mm4            ;mm5 = packed sums (2 dwords)
    pshufw mm6,mm5,00001110b ;mm6[31:0] = mm5[63:32]
    padd  mm6,mm5            ;mm6[31:0] = final sum_x
    movd  eax,mm6            ;eax = sum_x
    emms                      ;clear mmx state

```

```

; Compute mean value
    mov dword ptr [ebp-8],eax           ;save sum_x as 64-bit value
    mov dword ptr [ebp-4],0
    fild qword ptr [ebp-8]            ;load sum_x
    fild dword ptr [ebp+12]           ;load n
    fdivp                               ;mean = sum_x / n

    mov edx,[ebp+20]
    fstp real8 ptr [edx]              ;save mean
    mov edx,[ebp+16]
    mov [edx],eax                     ;save sum_x
    mov eax,1                          ;set return code

Done:  mov esp,ebp
       pop ebp
       ret
MmxCalcMean_ endp
       end

```

The general structure of sample program `MmxCalcMean` is similar to `MmxCalcMinMax`. Near the top of `MmxCalcMean.cpp` (Listing 6-14) is a function named `MmxCalcMeanCpp` that computes the mean of an 8-bit unsigned integer array. The maximum size of the array is restricted in order to prevent an arithmetic overflow during summation of the array elements. The function `MmxCalcMean` creates a test array, invokes `MmxCalcMeanCpp` and `MmxCalcMean_`, and displays the results. Sample program `MmxCalcMean` also includes a benchmark function named `MmxCalcMeanTimed` (source code not shown) that measures the execution time of both `MmxCalcMeanCpp` and `MmxCalcMean_`.

Like its C++ counterpart, the x86 assembly language function `MmxCalcMean_` (Listing 6-15) starts by validating the size of the array. Next, the function sets up a processing loop that sums the array's elements. During computation of the array sum, the processing loop performs two separate size promotions in order to avoid an arithmetic overflow. This process is illustrated in Figure 6-5. First, the 16 array elements are promoted from unsigned bytes to unsigned words using the `punpcklbw` and `punpckhbw` instructions (note that the source operand `MM7` contains all zeros). These values are then summed using a series of `paddw` instructions. Following execution of the final `paddw` instruction, register `MM0` contains four intermediate sums. The sum values are then promoted to doublewords and added to the packed doubleword sums in register pair `MM5:MM4`.

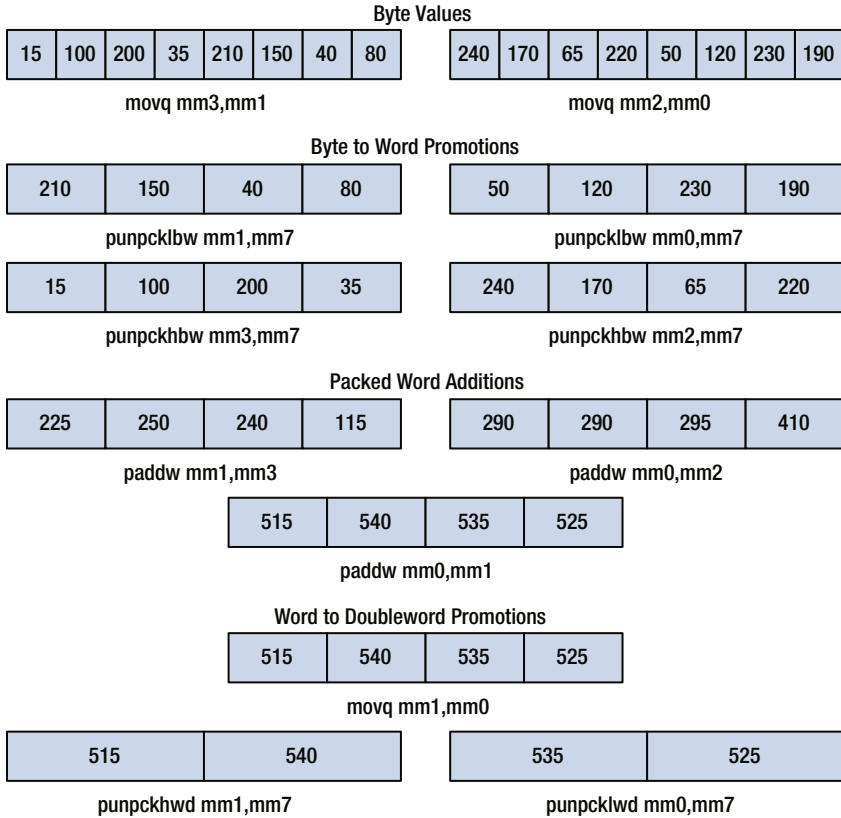

Note: mm7 = 0x0000000000000000

Figure 6-5. Processing loop array element size promotions

Subsequent to the completion of the summation loop, the final value of `sum_x` is calculated using two `paddw` instructions and a `pshufw` instruction, which reduces the four intermediate doubleword sums to the required final value. This value is then copied into register `EAX`. Before the final mean value can be computed, an `emms` instruction is executed in order to return the x87 FPU to normal operation. The value of `sum_x` is then saved to a local memory location on the stack as a 64-bit signed integer (recall that the x87 FPU does not support unsigned integer operands or data transfers to or from an x86 general-purpose registers). The final mean value is then calculated using the x87 FPU.

Output 6-5 shows the results of the sample program `MmxCalcMean`. Table 6-2 also contains a summary of the benchmark times that were obtained for the C++ and assembly language versions of the array mean calculating algorithm.

Output 6-5. Sample Program MmxCalcMean

```
Results for MmxCalcMean()
rc1: 1 sum_x1: 1069226624 mean_x1: 127.461746
rc2: 1 sum_x2: 1069226624 mean_x2: 127.461746
```

```
Results for MmxCalcMeanTimed()
sum1: 1069226624 mean1: 127.461746
sum2: 1069226624 mean2: 127.461746
```

Benchmark times saved to file `__MmxCalcMeanTimed.csv`

Table 6-2. Mean Execution Times (in Microseconds) for MmxCalcMean Functions

CPU	MmxCalcMeanCpp (C++)	MmxCalcMean_ (x86-32 MMX)
Intel Core i7-4770	1750	843
Intel Core i7-4600U	2074	995
Intel Core i3-2310M	4184	1704

Summary

In this chapter, you learned how to perform some basic SIMD arithmetic and shift operations using the MMX instruction set. Additionally, you analyzed a couple of sample programs that demonstrated the performance benefits of using MMX technology to implement realistic integer array processing algorithms. These latter sample programs also elucidated proper use of several essential MMX instructions, including `pshufw`, `punpcklbw`, `punpckhbw`, `punpcklwd`, and `punpckhwd`.

In order to fully exploit the benefits of a SIMD architecture, software developers must frequently “forget” long-established coding strategies, techniques, and constructs. The design and implementation of effective SIMD algorithms usually requires an extreme shift in programming mindset; it’s not uncommon for even experienced software developers to undergo a little retooling of their programming ethos when learning to use a SIMD architecture. In the next four chapters, you’ll continue your exploration of the x86’s SIMD platforms by examining the computational resources of x86-SSE.



Streaming SIMD Extensions

In Chapters 5 and 6, you examined MMX technology, which was the x86 platform's first SIMD enhancement. In this chapter, you'll explore the successor to MMX technology. X86 Streaming SIMD Extensions (x86-SSE) refers to a collection of architectural enhancements that have steadily advanced the SIMD computing capabilities of the x86 platform. X86-SSE adds new registers and instructions that facilitate SIMD computations using packed floating-point data types. It also extends the integer SIMD processing capabilities of MMX technology.

Chapter 7 begins with a brief overview of x86-SSE, including its various versions and capabilities. This is followed by a detailed examination of the execution environment that focuses on x86-SSE's registers, supported data types, and control-status mechanisms. You'll also examine some fundamental x86-SSE processing techniques that will help elucidate the platform's computational capabilities. The final section of this chapter presents an overview of the x86-SSE instruction set.

The explanations and discussions in this chapter focus on using x86-SSE in an x86-32 execution environment. If you're interested in developing x86-64 based x86-SSE programs, you'll need to thoroughly understand the material presented in this chapter, along with the content of Chapter 19.

X86-SSE Overview

The original Streaming SIMD Extension, called SSE, was introduced with the Pentium III processor. SSE adds new registers and instructions that facilitate SIMD operations using packed single-precision floating-point values. SSE also includes new instructions for scalar single-precision floating-point arithmetic. The Pentium IV processor included an upgrade to SSE called SSE2, which broadens SSE's single-precision floating-point capabilities to include packed and scalar double-precision floating-point arithmetic. SSE2 also incorporates additional SIMD processing resources for packed integer data types. Later in this chapter, you'll learn more about the packed and scalar data types of SSE and SSE2.

Since the introduction of SSE2, there have been a number of constructive x86-SSE enhancements. SSE3 and SSSE3 (Supplemental SSE3) incorporate new instructions that perform SIMD horizontal (or adjacent element) arithmetic using packed floating-point and packed integer operands, respectively. These extensions also include a number of data transfer instructions that offer either improved performance or additional programming flexibility. SSE4.1 augments the x86 platform with new instructions that perform advanced SIMD operations, including dot products and data blending. It also

adds new data insertion, data extraction, and floating-point rounding instructions. The final x86-SSE enhancement, called SSE4.2, adds SIMD text string processing capabilities to the x86 platform. Table 7-1 summarizes the evolution of x86-SSE, which uses the acronyms SPFP and DPFP to signify single-precision floating-point and double-precision floating-point, respectively.

Table 7-1. *Evolution of X86-SSE*

Release	Data Types	Key Features and Enhancements
SSE	Packed SPFP Scalar SPFP	SIMD arithmetic using packed SPFP Scalar arithmetic using SPFP Cache control instructions Memory ordering instructions
SSE2	Packed SPFP, DPFP Scalar SPFP, DPFP Packed integers	SIMD arithmetic using packed SPFP and DPFP Scalar arithmetic using SPFP and DPFP SIMD processing using packed integers Additional cache control instructions
SSE3	Same as SSE2	Horizontal addition and subtraction using packed SPFP and DPFP operands Enhanced data transfer instructions
SSSE3	Same as SSE2	Horizontal addition and subtraction using packed integer operands Enhanced SIMD processing instructions using packed integers
SSE4.1	Same as SSE2	SPFP and DPFP dot products SPFP and DPFP blend instructions XMM register insertion and extraction instructions Packed integer blend instructions
SSE4.2	Same as SSE2 Packed text strings	Packed text strings instructions CRC acceleration instructions

Additional details regarding the key features and enhancements shown in Table 7-1 are provided throughout this chapter and in Chapters 8 through 11. As a reminder, this book uses the term x86-SSE to describe generic or common capabilities of the x86 platform's Streaming SIMD Extensions. When discussing aspects or instructions of a specific SIMD enhancement, the acronyms shown in Table 7-1 are used.

X86-SSE Execution Environment

In this section, you'll examine the execution environment of x86-SSE starting with a description of its register set. This is followed by a discussion of the various packed and scalar data types that x86-SSE supports. You'll also take a look at the x86-SSE control-status

register, which can be used to configure x86-SSE processing options and detect error conditions. The content of this section assumes that you have a basic understanding of MMX technology, which was described in Chapter 5.

X86-SSE Register Set

X86-SSE adds eight 128-bit wide registers to the x86-32 platform, as illustrated in Figure 7-1. These registers are named XMM0-XMM7 and can be employed to carry out computations using scalar and packed single-precision floating-point values. On processors that support SSE2, the XMM registers are capable of performing calculations using scalar and packed double-precision floating-point values. SSE2 also supports use of the XMM registers to perform a variety of SIMD operations using packed integer values.

127	XMM 0	0
	XMM 1	
	XMM 2	
	XMM 3	
	XMM 4	
	XMM 5	
	XMM 6	
	XMM 7	

Figure 7-1. X86-SSE register set in x86-32 mode

Unlike the MMX registers, the XMM registers are not aliased with the x87 FPU registers. This means that a program can switch between x86-SSE and x87-FPU instructions without having to save or restore any state information. The XMM registers are also directly addressable; a stack-based architecture is not used. Data can be transferred between an XMM register and memory using any of the addressing modes described in Chapter 1. The XMM registers cannot be used to address operands in memory.

X86-SSE Data Types

X86-SSE supports a variety of packed and scalar data types, as illustrated in Figure 7-2. A 128-bit wide XMM register or memory location can accommodate four single-precision or two double-precision floating-point values. When working with packed integer values, a 128-bit wide operand is capable of holding sixteen byte, eight word, four doubleword, or two quadword items. The low-order doubleword and quadword of an XMM register also can be used to perform computations using scalar single-precision and double-precision floating-point values, respectively.

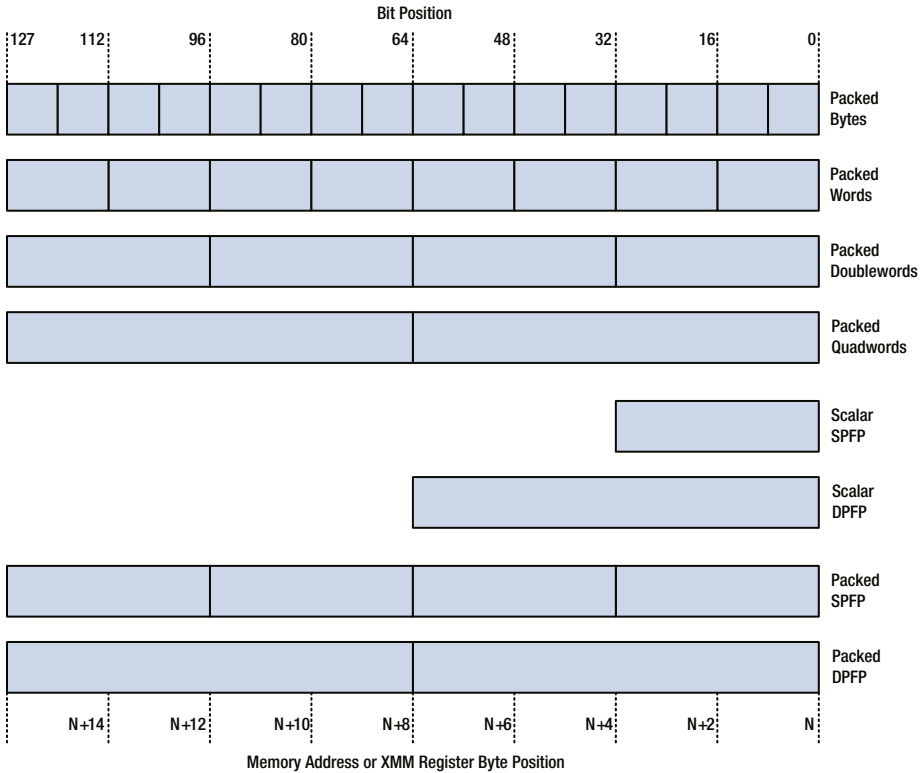

Figure 7-2. X86-SSE supported data types

When referencing an operand in memory, nearly all x86-SSE instructions that use 128-bit wide operands require such operands to be properly aligned. This means that the address of a packed integer or packed floating-point value in memory must be evenly divisible by 16. The only exception to this rule applies to a small set of x86-SSE move instructions that are intended to perform data transfers between an XMM register and an improperly aligned packed data value. Otherwise, the processor will generate an exception if an x86-SSE instruction attempts to access a misaligned operand in memory. It is important to recognize that this memory alignment requirement applies to x86-SSE data values that are defined in both C++ and assembly language functions. In Chapters 9 and 10, you’ll learn a couple of techniques that can be used to specify the alignment of data values defined in a Visual C++ function.

Scalar single-precision and double-precision floating-point values can be copied from an unaligned memory location to an XMM register or vice versa. However, like all other x86 multi-byte values, proper alignment of scalar floating-point values is strongly recommended in order to avoid potential performance penalties. Finally, unlike the x87-FPU, x86-SSE does not support packed BCD data types.

X86-SSE Control-Status Register

The x86-SSE execution environment includes a 32-bit control-status register. This register, named MXCSR, contains a series of control flags that enable a program to specify options for floating-point calculations and exceptions. It also includes a set of status flags that can be tested to detect x86-SSE floating-point error conditions. Figure 7-3 shows the organization of the bits in MXCSR; Table 7-2 describes the purpose of each bit field.

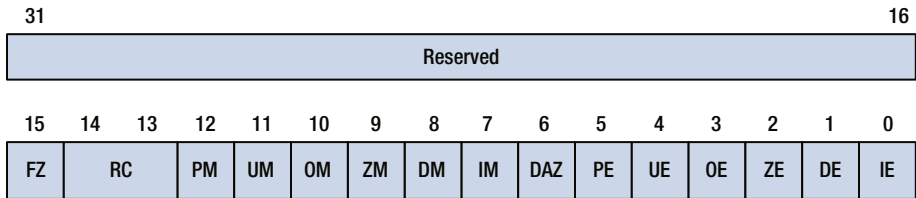

Figure 7-3. X86-SSE MXCSR control and status register

Table 7-2. X86-SSE MXCSR Control and Status Register Fields

Bit	Field Name	Description
IE	Invalid operation flag	X86-SSE floating-point invalid operation error flag.
DE	Denormal flag	X86-SSE floating-point denormal error flag.
ZE	Divide-by-zero flag	X86-SSE floating-point division-by-zero error flag.
OE	Overflow flag	X86-SSE floating-point overflow error flag.
UE	Underflow flag	X86-SSE floating-point underflow error flag.
PE	Precision flag	X86-SSE floating-point precision error flag.
DAZ	Denormals are zeros	When set to 1, forcibly converts a denormal source operand to zero prior to its use in a calculation.
IM	Invalid operation mask	X86-SSE floating-point invalid operation error exception mask.
DM	Denormal mask	X86-SSE floating-point denormal error exception mask.
ZM	Divide-by-zero-mask	X86-SSE floating-point divide-by-zero error exception mask.
OM	Overflow mask	X86-SSE floating-point overflow error exception mask.
UM	Underflow mask	X86-SSE floating-point underflow error exception mask.
PM	Precision mask	X86-SSE floating-point precision error exception mask.

(continued)

Table 7-2. (continued)

Bit	Field Name	Description
RC	Rounding control	Specifies the method for rounding X86-SSE floating-point results. Valid options include round to nearest (00b), round down toward $-\infty$ (01b), round up toward $+\infty$ (10b), and round toward zero or truncate (11b).
FZ	Flush to zero	When set to 1, forces a zero result if the underflow exception is masked and an X86-SSE floating-point underflow error occurs.

An application program can modify any of the MXCSR's control flags or status bits to accommodate its specific SIMD floating-point processing requirements. Any attempt to write a non-zero value to a reserved bit position will cause the processor to generate an exception. The MXCSR's status flags are not automatically cleared by the processor following the occurrence of an error condition; they must be manually reset. The control flags and status bits of the MXCSR register can be modified using either the `ldmxcsr` (Load MXCSR Register) or `fxrstor` (Restore x87 FPU, MMX, XMM, and MXCSR State) instruction.

The processor sets an MXCSR error flag to 1 following the occurrence of an error condition. Setting the MXCSR.DAZ control flag to 1 can improve the performance of algorithms where the rounding of a denormal value to zero is acceptable. Similarly, the MXCSR.FZ control flag can be used to accelerate computations where floating-point underflows are common. The downside of using either of these control flag options is non-compliance with the IEEE 754 floating-point standard.

X86-SSE Processing Techniques

An x86 processor uses several different techniques to process x86-SSE data types. Most x86-SSE SIMD operations involving packed integer operands are carried out using the same calculations as MMX technology, except that the calculations are performed using 128-bit instead of 64-bit wide operands. For example, Figure 7-4 illustrates x86-SSE SIMD addition using packed byte, word, and doubleword unsigned integers. X86-SSE also supports SIMD arithmetic using packed single-precision and double-precision floating-point data types. Figures 7-5 and 7-6 show some common x86-SSE SIMD arithmetic operations using packed single-precision and double-precision floating-point values.

X86-SSE Packed Unsigned Byte Addition																	
	90	10	220	170	60	120	15	105	25	130	50	75	95	200	225	85	src
+	80	240	15	20	75	105	50	80	60	15	60	70	125	30	10	95	des
<hr/>																	
	170	250	235	190	135	225	65	185	85	145	110	145	220	230	235	180	des

X86-SSE Packed Unsigned Word Addition									
	1700	2300	6000	500	22000	15500	12000	18000	src
+	9000	80	300	900	8500	16750	32700	25000	des
<hr/>									
	10700	2380	6300	1400	30500	32250	44700	43000	des

X86-SSE Packed Unsigned Doubleword Addition					
	120000	275000	65000	420500	src
+	800000	1800	300750	70500	des
<hr/>					
	920000	276800	365750	491000	des

Figure 7-4. X86-SSE addition using packed unsigned integer values

X86-SSE Packed Single-Precision Floating-Point Addition					
	12.0	37.25	100.875	0.125	src
+	88.0	98.5	-50.625	-0.375	des
<hr/>					
	100.0	135.75	50.25	-0.25	des

X86-SSE Packed Single-Precision Floating-Point Multiplication					
	1.5	100.25	1000.0	-50.125	src
×	-200.25	3.625	250.875	-40.75	des
<hr/>					
	-300.375	363.40625	250875.0	2042.59375	des

Figure 7-5. X86-SSE arithmetic using packed single-precision floating-point values

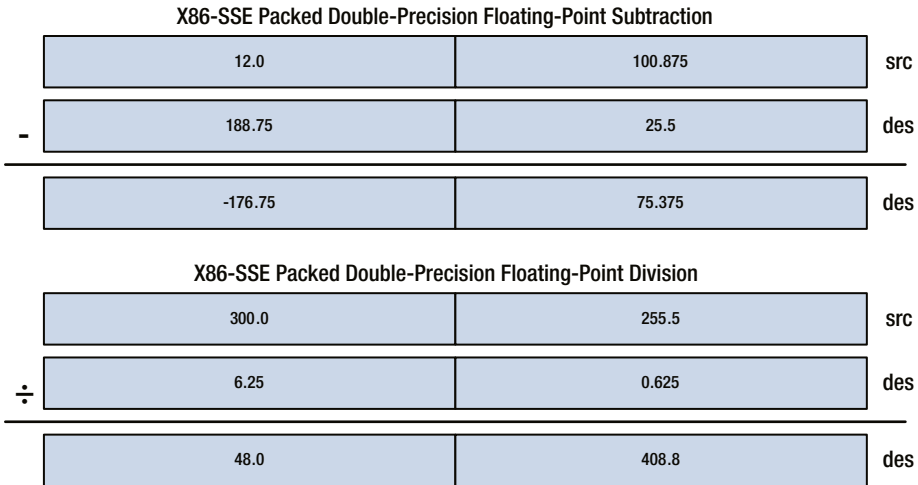

Figure 7-6. X86-SSE arithmetic using packed double-precision floating-point values

X86-SSE also can be used to perform scalar floating-point arithmetic using single-precision or double-precision values. Figure 7-7 illustrates a couple of examples. Note that when performing x86-SSE scalar floating-point arithmetic, only the low-order element of the destination operand is modified; the high-order elements are not affected. The scalar floating-point capabilities of x86-SSE are often used as a modern alternative to the x87 FPU. The reasons for this technological shift include faster performance and directly-addressable registers. Having directly-addressable registers enables high-level language compilers to generate machine code that is more efficient. It also simplifies considerably the coding of x86 assembly language functions that need to perform scalar floating-point arithmetic.

X86-SSE Scalar Single-Precision Floating-Point Addition					
	17.0	42.375	56.125	12.625	src
+	5.5	200.875	3216.75	2000.0	des
<hr/>					
	5.5	200.875	3216.75	2012.625	des
X86-SSE Scalar Double-Precision Floating-Point Multiplication					
	300.0		642.75		src
×	6.25		-0.50		des
<hr/>					
	6.25		-321.375		des

Figure 7-7. X86-SSE arithmetic using scalar floating-point values

X86-SSE also supports horizontal arithmetic operations. A horizontal arithmetic operation carries out its computations using the adjacent elements of a packed data type. Figure 7-8 illustrates horizontal addition using single-precision floating-point and horizontal subtraction using double-precision floating-point operands. The x86-SSE instruction set also supports integer horizontal addition and subtraction using packed words and doublewords. Horizontal operations are frequently used to reduce a packed data operand that contains multiple intermediate values to a single result.

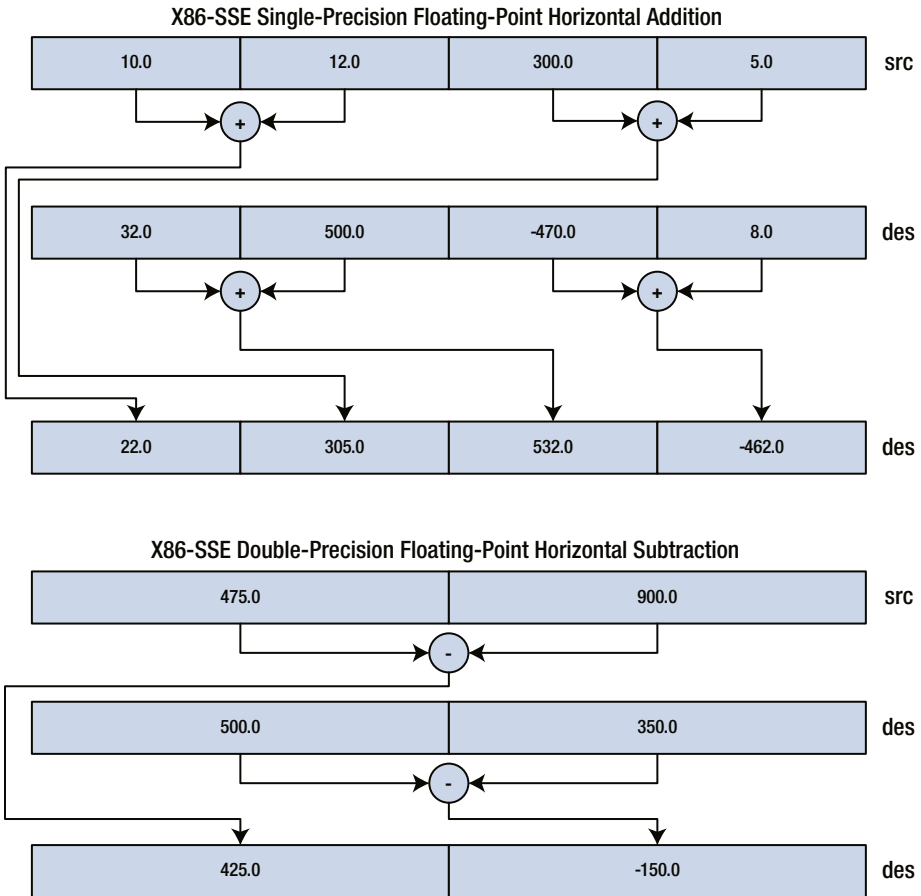

Figure 7-8. X86-SSE horizontal addition and subtraction using single-precision and double-precision floating-point values

X86-SSE Instruction Set Overview

The following section presents a brief overview of the x86-SSE instruction set. It observes the same format used by other instruction set summaries in this book. The x86-SSE instruction set can be partitioned into the following functional groups:

- Scalar floating-point data transfer
- Scalar floating-point arithmetic
- Scalar floating-point comparison
- Scalar floating-point conversion
- Packed floating-point data transfer

- Packed floating-point arithmetic
- Packed floating-point comparison
- Packed floating-point conversion
- Packed floating-point shuffle and unpack
- Packed floating-point insertion and extraction
- Packed floating-point blend
- Packed floating-point logical
- Packed integer extensions
- Packed integer data transfer
- Packed integer arithmetic
- Packed integer comparison
- Packed integer conversion
- Packed integer shuffle and unpack
- Packed integer insertion and extraction
- Packed integer blend
- Packed integer shift
- Text string processing
- Non-temporal data transfer and cache control
- Miscellaneous

Unless otherwise stated, an x86-SSE instruction can use either an XMM register or a memory location as a source operand. Packed 128-bit wide source operands located in memory must be aligned on a 16-byte boundary, except for instructions that explicitly support unaligned data transfers. Aside from the data transfer instructions, the destination operand of an x86-SSE instruction must be an XMM register.

A program can intermix x86-SSE and MMX instructions. This may be appropriate for code maintenance and migration scenarios. X86-SSE based programs that use the MMX instruction set are still required to use the `emms` instruction before using any x87 FPU instructions. Intermixing of x86-SSE and MMX instructions is not recommended for new development.

The instruction descriptions use the acronyms SPFP and DPFP to denote single-precision floating-point and double-precision floating-point, respectively. Most x86-SSE floating-point instruction mnemonics use two-letter codes to denote the operand type, including `ps` (Packed SPFP), `pd` (Packed DPFP), `ss` (Scalar SPFP), and `sd` (Scalar DPFP). Additional information regarding x86-SSE instruction use, including valid operands and potential exceptions, is available in the reference manuals published by AMD and Intel. A list of these manuals is included in Appendix C. The sample code of Chapters 8 through 11 also contains elucidatory comments regarding specific x86-SSE instructions.

Scalar Floating-Point Data Transfer

The scalar floating-point data transfer group contains instructions that are used to transfer scalar SPFP and DPFP values between an XMM register and a memory location, as shown in Table 7-3.

Table 7-3. X86-SSE Scalar Floating-Point Data Transfer Instructions

Mnemonic	Description	Version
movss movsd	Copies a scalar floating-point value between two XMM registers or between a memory location and an XMM register.	SSE/SSE2

Scalar Floating-Point Arithmetic

The scalar floating-point arithmetic group contains instructions that perform basic arithmetic using scalar operands. These instructions can be used instead of or in conjunction with the x87 FPU. For all instructions, the source operand can be a memory location or an XMM register. The destination operand must be an XMM register. Table 7-4 summarizes the scalar floating-point arithmetic instructions.

Table 7-4. X86-SSE Scalar Floating-Point Arithmetic Instructions

Mnemonic	Description	Version
addss addsd	Performs a scalar addition using the specified operands.	SSE/SSE2
subss subsd	Performs a scalar subtraction using the specified operands. The source operand specifies the subtrahend and the destination operand specifies the minuend.	SSE/SSE2
mulss mulsd	Performs a scalar multiplication using the specified operands.	SSE/SSE2
divss divsd	Performs a scalar division using the specified operands. The source specifies the divisor and the destination operand specifies the dividend.	SSE/SSE2
sqrtps sqrtss	Computes the square root of the specified source operand.	SSE/SSE2
maxss maxsd	Compares the source and destination operands and saves the larger value in the destination operand.	SSE/SSE2

(continued)

Table 7-4. (continued)

Mnemonic	Description	Version
minss minsd	Compares the source and destination operands and saves the smaller value in the destination operand.	SSE/SSE2
roundss roundsd	Rounds a scalar floating-point value using the rounding method specified by an immediate operand.	SSE4.1
rcpss	Computes an approximate reciprocal of the specified operand.	SSE
rsqrtss	Computes an approximate reciprocal square root of the specified operand.	SSE

Scalar Floating-Point Comparison

The scalar floating-point comparison group contains instructions that perform compare operations between two scalar floating-point values. These instructions are summarized in Table 7-5.

Table 7-5. X86-SSE Scalar Floating-Point Comparison Instructions

Mnemonic	Description	Version
cmpss cmpsd	Compares two scalar floating-point values. An immediate operand specifies the comparison operator. The results of the comparison are saved to the destination operand (all 1s signifies true; all 0s signifies false).	SSE/SSE2
comiss comisd	Performs an ordered compare of two scalar floating-point values and reports the results using EFLAGS.ZF, EFLAGS.PF, and EFLAGS.CF.	SSE/SSE2
ucomiss ucomisd	Performs an unordered compare of two scalar floating-point values and reports the results using EFLAGS.ZF, EFLAGS.PF, and EFLAGS.CF.	SSE/SSE2

Scalar Floating-Point Conversion

The floating-point scalar conversion group contains instructions that are used to convert scalar SPFP values to DPFP and vice versa. Conversions to and from doubleword integers are also supported. Table 7-6 summarizes the scalar floating-point conversion instructions.

Table 7-6. X86-SSE Scalar Floating-Point Conversion Instructions

Mnemonic	Description	Version
cvttsi2ss cvttsi2sd	Converts a signed-doubleword integer to a floating-point value. The source operand can be a memory location or a general-purpose register. The destination operand must be an XMM register.	SSE/SSE2
cvtss2si cvtss2sd	Converts a floating-point value to a signed doubleword integer. The source operand can be a memory location or an XMM register. The destination operand must be a general-purpose register.	SSE/SSE2
cvttsd2si cvttsd2sd	Converts a floating-point value to a doubleword integer using truncation. The source operand can be a memory location or an XMM register. The destination operand must be a general-purpose register.	SSE/SSE2
cvtss2sd	Converts a SPFP value to a DPFP value. The source operand can be a memory location or an XMM register. The destination operand must be an XMM register.	SSE2
cvtss2sd	Converts a DPFP value to a SPFP value. The source operand can be a memory location or an XMM register. The destination operand must be an XMM register.	SSE2

Packed Floating-Point Data Transfer

The packed floating-point data transfer group includes instructions that copy packed floating-point data values between a memory location and an XMM register or two XMM registers. Table 7-7 summarizes the packed floating-point data transfer instructions.

Table 7-7. X86-SSE Packed Floating-Point Data Transfer Instructions

Mnemonic	Description	Version
movaps movapd	Copies a packed SPFP/DPFP value between a memory location and an XMM register or two XMM registers.	SSE/SSE2
movups movupd	Copies a packed SPFP/DPFP value between an unaligned memory location and an XMM register or two XMM registers.	SSE/SSE2

(continued)

Table 7-7. (continued)

Mnemonic	Description	Version
movlps movlpd	Copies the low-order quadword of a packed SPFP/DPFP value from memory to an XMM register or vice versa. If the destination is an XMM register, the high-order quadword is not modified.	SSE/SSE2
movhps movhpd	Copies the high-order quadword of a packed SPFP/DPFP value from memory to an XMM register or vice versa. If the destination is an XMM register, the low-order quadword is not modified.	SSE/SSE2
movlhps	Copies the low-order quadword of a packed SPFP source operand to the high-order quadword of the destination operand. Both operands must be XMM registers.	SSE
movhlps	Copies the high-order quadword of a packed SPFP source operand to the low-order quadword of the destination operand. Both operands must be XMM registers.	SSE
movsldup	Copies the low-order SPFP value of each quadword in the source operand to the same position in the destination operand. The low-order SPFP value of each destination operand quadword is then duplicated in the high-order 32 bits.	SSE3
movshdup	Copies the high-order SPFP value of each quadword in the source operand to the same position in the destination operand. The high-order SPFP value of each destination operand quadword is then duplicated in the low-order 32 bits.	SSE3
movddup	Copies the low-order DPFP value of the source operand to the low-order and high-order quadwords of the destination operand.	SSE3
movmskps movmskpd	Extracts the sign bits from each packed SPFP/DPFP data element in the source operand and stores them in the low-order bits of a general-purpose register. The high-order bits are set to zero.	SSE/SSE2

Packed Floating-Point Arithmetic

The packed floating-point arithmetic group includes instructions that perform basic arithmetic operations using packed single-precision and double-precision floating-point operands. Table 7-8 outlines these instructions.

Table 7-8. X86-SSE Packed Floating-Point Arithmetic Instructions

Mnemonic	Description	Version
addps addpd	Performs a packed floating-point addition using the data elements of the source and destination operands.	SSE/SSE2
subps subpd	Performs a packed floating-point subtraction using the data elements of the source and destination operands. The source operand contains the subtrahends and the destination operands contain the minuends.	SSE/SSE2
mulps mulpd	Performs a packed floating-point multiplication using the data elements of the source and destination operands.	SSE/SSE2
divps divpd	Performs a packed floating-point division using the data elements of the source and destination operands. The source operand contains the divisors and the destination operand contains the dividends.	SSE/SSE2
sqrtps sqrtpd	Computes the square roots of the packed floating-point data elements in the source operand.	SSE/SSE2
maxps maxpd	Compares the floating-point data elements of the source and destination operands and saves the larger values in the destination operand.	SSE/SSE2
minps minpd	Compares the floating-point data elements of the source and destination operands and saves the smaller values in the destination operand.	SSE/SSE2
rcpps	Computes an approximate reciprocal of each floating-point element.	SSE/SSE2
rsqrtps	Computes an approximate reciprocal square root of each floating-point element.	SSE
addsubps addsubpd	Adds the odd-numbered floating-point elements and subtracts the even-numbered floating-point elements.	SSE3

(continued)

Table 7-8. (continued)

Mnemonic	Description	Version
dpps dppd	Performs a conditional multiplication of the packed floating-point elements followed by an addition. This instruction is used to calculate dot products.	SSE4.1
roundps roundpd	Rounds the specified packed floating-point data elements using the rounding mode that is specified by an immediate operand.	SSE4.1
haddps haddpd	Adds adjacent floating-point data elements contained in the source and destination operands.	SSE3
hsubps hsubpd	Subtracts adjacent floating-point data elements contained in the source and destination operands.	SSE3

Packed Floating-Point Comparison

The packed floating-point comparison group includes instructions that perform compare operations using the data elements of a packed floating-point data value. Table 7-9 lists the instructions in this group.

Table 7-9. X86-SSE Packed Floating-Point Comparison Instructions

Mnemonic	Description	Version
cmpps cmppd	Compares the floating-point data elements of the source and destination operands using the specified immediate comparison operator. The results of the comparison are saved to the destination operand (all 1s signifies true; all 0s signifies false).	SSE/SSE2

Packed Floating-Point Conversion

The packed floating-point conversion group contains instructions that convert the data elements of a packed floating-point operand from one data type to another. Table 7-10 reviews the instructions in this group.

Table 7-10. X86-SSE Packed Floating-Point Conversion Instructions

Mnemonic	Description	Version
cvtpi2ps cvtpi2pd	Converts two packed signed doubleword integers to two packed floating-point values. The source operand can be a memory location or an MMX register. The destination operand must be an XMM register.	SSE/SSE2
cvtps2pi cvtpd2pi	Converts two packed floating-point values to two packed signed doubleword integers. The source operand can be a memory location or an XMM register. The destination operand must be an MMX register.	SSE/SSE2
cvttps2pi cvttpd2pi	Converts two packed floating-point values to two signed doubleword integers using truncation. The source operand can be a memory location or an XMM register. The destination operand must be an MMX register.	SSE/SSE2
cvtdq2ps	Converts four packed signed doubleword integers to four packed single-precision floating-point values.	SSE2
cvtdq2pd	Converts two packed signed doubleword integers to two packed double-precision floating-point values.	SSE2
cvtps2dq	Converts four packed single-precision floating-point values to four packed signed-doubleword integers.	SSE2
cvttps2dq	Converts four packed single-precision floating-point values to four packed signed doubleword integers using truncation as the rounding mode.	SSE2
cvtpd2dq	Converts two packed double-precision floating-point values to two packed signed doubleword integers.	SSE2
cvttpd2pq	Converts two packed double-precision floating-point values to two packed signed doubleword integers using truncation as the rounding mode.	SSE2
cvtps2pd	Converts two packed single-precision floating-point values to two packed double-precision floating-point values.	SSE2
cvtpd2ps	Converts two packed double-precision floating-point values to two packed single-precision floating-point values.	SSE2

Packed Floating-Point Shuffle and Unpack

The packed floating-point shuffle and unpack group contains instructions that are used to reorder the data elements of a packed floating-point operand. These instructions are shown in Table 7-11.

Table 7-11. X86-SSE Packed Floating-Point Shuffle and Unpack Instructions

Mnemonic	Description	Version
shufps shufpd	Moves the specified elements in both the source and destination operands to the destination operand. An 8-bit immediate operand specifies which elements to move.	SSE/SSE2
unpcklps unpcklpd	Unpacks and interleaves the low-order elements of the source and destination operands and places the result in the destination operand.	SSE/SSE2
unpckhps unpckhpd	Unpacks and interleaves the high-order elements of the source and destination operands and places the result in the destination operand.	SSE/SSE2

Packed Floating-Point Insertion and Extraction

The floating-point insertion and extraction group contains instructions that insert or extract elements from packed single-precision floating-point operands. Table 7-12 summarizes these instructions.

Table 7-12. X86-SSE Packed Floating-Point Insertion and Extraction Instructions

Mnemonic	Description	Version
insertps	Copies a SPFP value from the source operand and inserts it into the destination operand. The source operand can be a memory location or an XMM register. The destination operand must be an XMM register. The destination operand element is specified by an immediate operand.	SSE4.1
extractps	Extracts a SPFP element from the source operand and copies it to the destination operand. The source operand must be an XMM register. The destination operand can be a memory location or a general-purpose register. The location of the element to extract is specified by an immediate operand.	SSE4.1

Packed Floating-Point Blend

The packed floating-point blend group contains instructions that are used to conditionally copy and merge packed floating-point data values. Table 7-13 presents an overview of these instructions.

Table 7-13. X86-SSE Packed Floating-Point Blend Instructions

Mnemonic	Description	Version
blendps blendpd	Conditionally copies floating-point elements from the source and destination operands to the destination operand. An immediate operand designates the specific elements to copy.	SSE4.1
blendvps blendvpd	Conditionally copies floating-point elements from the source and destination operands to the destination operand. A mask value in the XMM0 register designates the specific to copy.	SSE4.1

Packed Floating-Point Logical

The packed floating-point logical group contains instructions that perform bitwise logical operations using packed floating-point operands. Table 7-14 describes these instructions.

Table 7-14. X86-SSE Packed Floating-Point Logical Instructions

Mnemonic	Description	Version
andps andpd	Performs a bitwise logical AND of the data elements in the specified packed floating-point operands.	SSE/SSE2
andnps andnpd	Performs a bitwise logical NOT of the destination operand following by a bitwise logical AND of the source and destination operands.	SSE/SSE2
orps orpd	Performs a bitwise logical inclusive OR of the data elements in the specified packed floating-point operands.	SSE/SSE2
xorps xorpd	Performs a bitwise logical exclusive OR of the data elements in the specified packed floating-point operands.	SSE/SSE2

Packed Integer Extensions

SSE2 extends the packed-integer capabilities of the x86-platform in two ways. First, all of the packed integer instructions defined by MMX technology (except `psuq`) can use the XMM registers and 128-bit wide memory locations as operands. Second, SSE2 and the subsequent x86 SIMD extensions include a number of new packed integer instructions that require at least one operand to be an XMM register or a 128-bit memory location. These instructions are reviewed in the following sections.

Packed Integer Data Transfer

The packed integer data transfer group contains instructions that are used to move packed integer values between an XMM register and memory location or two XMM registers. This group also contains instructions that perform data moves between an XMM register and an MMX register. Table 7-15 lists the packed integer data transfer group instructions.

Table 7-15. X86-SSE Packed Integer Data Transfer Instructions

Mnemonic	Description	Version
movdqa	Copies an aligned double quadword from memory to an XMM register or vice versa. This instruction also can be used to perform XMM register-to-register transfers.	SSE2
movdqu	Copies an unaligned double quadword from memory to an XMM register or vice versa.	SSE2
movq2dq	Copies the contents of an MMX register to the lower quadword of an XMM register. This instruction causes a transition of the x87 FPU to MMX mode.	SSE2
movdq2q	Copies the lower quadword of an XMM register to an MMX register. This instruction causes a transition of the x87 FPU to MMX mode.	SSE2

Packed Integer Arithmetic

The packed integer arithmetic group contains instructions that perform arithmetic operations using packed integer operands. Table 7-16 describes these instructions.

Table 7-16. X86-SSE Packed Integer Arithmetic Instructions

Mnemonic	Description	Version
pmulld	Performs a packed signed multiplication between the source and destination operands. The low-order doubleword of each product is saved in the destination operand.	SSE4.1
pmuldq	Multiplies the first and third signed doublewords of source and destination operands. The quadword products are saved to the destination operand.	SSE4.1
pminub pminuw pminud	Compares two packed unsigned integer values and saves the smaller data element of each comparison to the destination operand. The source operand can be a memory location or a register. The destination operand must be a register.	SSE2 (pminub) SSE4.1

(continued)

Table 7-16. (continued)

Mnemonic	Description	Version
<code>pminsb</code> <code>pminsw</code> <code>pminsd</code>	Compares two packed signed integer values and saves the smaller data element of each comparison to the destination operand. The source operand can be a memory location or register. The destination operand must be a register.	SSE2 (<code>pminsw</code>) SSE4.1
<code>pmaxub</code> <code>pmaxuw</code> <code>pmaxud</code>	Compares two packed unsigned integer values and saves the larger data element of each comparison to the destination operand. The source operand can be a memory location or register. The destination operand must be a register.	SSE2 (<code>pmaxub</code>) SSE4.1
<code>pmxsb</code> <code>pmxsw</code> <code>pmxsd</code>	Compares two packed signed integer values and saves the larger data element of each comparison to the destination operand. The source operand can be a memory location or register. The destination operand must be a register.	SSE2 (<code>pmxsw</code>) SSE4.1

Packed Integer Comparison

The packed integer comparison group contains instructions that perform compare operations between two packed integer values. Table 7-17 summarizes the packed integer comparison instructions.

Table 7-17. X86-SSE Packed Integer Comparison Instructions

Mnemonic	Description	Version
<code>pcmpeqb</code> <code>pcmpeqw</code> <code>pcmpeqd</code> <code>pcmpeqq</code>	Compares two packed integer values element-by-element for equality. If the source and destination data elements are equal, the corresponding data element in the destination operand is set to all 1s; otherwise, the destination operand data element is set to all 0s.	SSE2 SSE4.1 (<code>pcmpeqq</code>)
<code>pcmpgtb</code> <code>pcmpgtw</code> <code>pcmpgtd</code> <code>pcmpgtq</code>	Compares two packed signed-integer values element-by-element for greater magnitude. If the destination element is larger, the corresponding data element is set to all 1s; otherwise, the destination operand data element is set to all 0s.	SSE2 SSE4.2 (<code>pcmpgtq</code>)

Packed Integer Conversion

The packed integer data conversion group contains instructions that convert packed integers from one type to another type. This group includes both sign-extend and zero-extend instruction variants. Table 7-18 lists the packed integer conversion instructions.

Table 7-18. X86-SSE Packed Integer Conversion Instructions

Mnemonic	Description	Version
packuswb packusdw	Converts n packed unsigned integers in both the source and destination operands to 2 * n packed unsigned integers using unsigned saturation.	SSE2 (packuswb) SSE4.1 (packusdw)
pmovsxbw pmovsxbd pmovsxbq	Sign extends the low-order signed-byte integers of the source operand and copies these values to the destination operand.	SSE4.1
pmovsxdw pmovsxwq	Sign extends the low-order signed-word integers of the source operand and copies these values to the destination operand.	SSE4.1
pmovsxdq	Sign extends the two low-order signed doubleword integers of the source operand and copies the resultant quadword values to the destination operand.	SSE4.1
pmovzxbw pmovzxbd pmovzxbq	Zero extends the low-order unsigned-integer bytes of the source operand and copies these values to the destination operand.	SSE4.1
pmovzxdw pmovzxwq	Zero extends the low-order unsigned-integer words of the source operand and copies these values to the destination operand.	SSE4.1
pmovzxdq	Zero extends the two low-order unsigned integer doublewords of the source operand and copies the resultant quadword values to the destination operand.	SSE4.1

Packed Integer Shuffle and Unpack

The packed integer shuffle and unpack group contains instructions that are used to re-order or unpack the elements of a packed integer data value. For all instructions in this group, the source operand can be an XMM register or a memory location; the destination operand must be an XMM register. Table 7-19 outlines the packed integer shuffle and unpack instructions.

Table 7-19. X86-SSE Packed Integer Shuffle and Unpack Instructions

Mnemonic	Description	Version
<code>pshufd</code>	Copies the doublewords of the source operand to the destination operand using an ordering scheme specified by an immediate operand.	SSE2
<code>pshuf1w</code>	Copies the low-order words of the source operand to the low-order words of the destination operand using an ordering scheme specified by an immediate operand.	SSE2
<code>pshufhw</code>	Copies the high-order words of the source operand to the high-order words of the destination operand using an ordering scheme specified by an immediate operand.	SSE2
<code>punpcklqdq</code>	Copies the low-order quadword of the source operand to the high-order quadword of the destination operand. The low-order quadword of the destination operand is unmodified.	SSE2
<code>punpckhqdq</code>	Copies the high-order quadword of the source operand to the high-order quadword of the destination operand. It also copies the high-order quadword of the destination to the low-order quadword of the destination.	SSE2

Packed Integer Insertion and Extraction

The packed integer insertion and extraction group contains byte, word, and doubleword insertion and extraction instructions. These instructions can be used to copy the low-order value of a general-purpose register into an XMM register location or vice versa. Table 7-20 lists the packed integer insertion and extraction instructions.

Table 7-20. X86-SSE Packed Integer Insertion and Extraction Instructions

Mnemonic	Description	Version
pinsrb pinsrw pinsrd	Copies an integer from the source operand to the destination operand. The position of the integer in the destination operand is specified using an immediate operand. The source operand can be a memory location or general-purpose register. The destination operand must be an XMM register.	SSE2 (pinsrw) SSE4.1
pextrb pextrw pextrd	Copies an integer from the source operand to the destination operand. The position of the integer in the source operand is specified using an immediate operand. The source operand must be an XMM register. The destination operand must be a memory location or a general-purpose register.	SSE2 (pextrw) SSE4.1

Packed Integer Blend

The packed integer blend group contains instructions that are used to conditionally copy and merge packed integer data values. Table 7-21 outlines these instructions.

Table 7-21. X86-SSE Packed Integer Blend Instructions

Mnemonic	Description	Version
pblendw	Conditionally copies word values from the source and destination operands to the destination operand. An immediate mask value designates the specific word values that are copied.	SSE4.1
pblendvb	Conditionally copies byte values from the source and destination operands to the destination operand. A mask value in register XMM0 designates the specific byte values that are copied.	SSE4.1

Packed Integer Shift

The packed integer shift group contains instructions that perform byte-oriented logical shifts using values in an XMM register. Table 7-22 describes these instructions.

Table 7-22. X86-SSE Packed Integer Shift Instructions

Mnemonic	Description	Version
pslldq	Performs a byte-oriented left shift of a packed integer value in an XMM register, filling the low-order bytes with zeros. The shift count is specified as an immediate operand.	SSE2
psrldq	Performs a byte-oriented right shift of a packed integer value in an XMM register, filling the high-order bytes with zeros. The shift count is specified as an immediate operand.	SSE2

Text String Processing

The text string processing group contains instructions that are used to perform string operations using explicit or implicit length strings. An explicit-length text string is a text string whose length is known in advance, while the length of an implicit-length text string must be determined by searching for an end-of-string character. The text string processing instructions can be used to perform SIMD text string compares and length calculations. They also can be used to accelerate text string search and replace algorithms. Table 7-23 summarizes the text string processing instructions.

Table 7-23. X86-SSE Text String Processing Instructions

Mnemonic	Description	Version
<code>pcmpestri</code>	Performs a packed compare of two explicit-length text strings; returns the index result in ECX.	SSE4.2
<code>pcmpestrm</code>	Performs a packed compare of two explicit-length text strings; returns the mask result in XMM0.	SSE4.2
<code>pcmpistri</code>	Performs a packed compare of two implicit-length text strings; returns the index result in ECX.	SSE4.2
<code>pcmpistrm</code>	Performs a packed compare of two implicit-length text strings; returns the mask result in XMM0.	SSE4.2

Non-Temporal Data Transfer and Cache Control

The non-temporal data transfer and cache control group contains instructions that perform non-temporal memory stores, cache pre-fetching and flushing, and memory load and store fencing. A non-temporal memory store notifies the processor that the data value can be written directly to memory without being stored in a processor memory cache. This can improve cache efficiency in certain applications (such as with audio and video encoding) since cache clutter is eliminated. The cache pre-fetching instructions notify the processor to load a cache data line into a specific cache level for future use. A memory-fence instruction serializes any pending memory load or store operations, which can improve the performance of multi-processor-based producer-consumer algorithms.

It should be noted that non-temporal memory stores, cache pre-fetching operations, and memory-fencing transactions are simply hints to the processor; the processor may choose to exploit or ignore any provided hints. Also note that the use of any hints does not affect the program execution state of the processor including its registers and status flags. It is neither necessary nor possible to include additional code that ascertains whether or not the processor accepted a hint. Table 7-24 lists the non-temporal data transfer and cache control instructions.

Table 7-24. X86-SSE Non-Temporal Data Transfer and Cache Control Instructions

Mnemonic	Description	Version
<code>movnti</code>	Copies the contents of a general-purpose register to memory using a non-temporal hint.	SSE2
<code>movntdq</code>	Copies the contents of an XMM register to memory using a non-temporal hint.	SSE2
<code>maskmovdqu</code>	Conditionally copies the bytes of an XMM register to memory using a non-temporal hint. A mask value, which is contained in a second XMM register, specifies the bytes that will be copied. Register EDI points to the destination memory location.	SSE2
<code>movntdqa</code>	Loads a memory-based double quadword into an XMM register using a non-temporal hint.	SSE4.1
<code>sfence</code>	Serializes all previously issued memory-store operations.	SSE
<code>lfence</code>	Serializes all previously issued memory-load operations.	SSE2
<code>mfence</code>	Serializes all previously issued memory-load and memory-store operations.	SSE2
<code>prefetchH</code>	Provides a hint to the processor that data can be loaded from main memory into cache memory. The source operand specifies the main memory location. The H is a placeholder that specifies the cache-hint type. Valid options are T0 (temporal data; all cache levels), T1 (temporal data; level 1 cache), T2 (temporal data; level 2 cache), or NTA (non-temporal data aligned; all cache levels).	SSE
<code>clflush</code>	Flushes and invalidates a cache line. The source operand specifies the memory location of the cache line.	SSE2

Miscellaneous

The miscellaneous instruction group contains instructions that can be used to manipulate x86-SSE control-status register MXCSR. It also contains several algorithm-specific acceleration instructions. These instructions are shown in Table 7-25.

Table 7-25. *X86-SSE Miscellaneous Instructions*

Mnemonic	Description	Version
<code>ldmxcsr</code>	Loads the x86-SSE MXCSR control-status register from memory.	SSE
<code>stmxcsr</code>	Saves the x86-SSE MXCSR control-status register to memory.	SSE
<code>fxsave</code>	Saves the current x87 FPU, MMX technology, XMM, and MXCSR state to memory. This instruction is intended to support operating system task switching but also can be used by application programs.	SSE
<code>fxrstor</code>	Loads an x87 FPU, MMX technology, XMM, and MXCSR state from memory. This instruction is intended to support operating system task switching but also can be used by application programs.	SSE
<code>crc32</code>	Accelerates the calculation of a 32-bit cyclic redundancy check (CRC). The source operand can be a memory location or general-purpose register. The destination operand must be a 32-bit general-purpose register and contain the previous intermediate result. The polynomial used to calculate the CRC is 0x11EDC6F41.	SSE4.2
<code>popcnt</code>	Counts the number of bits that are set to 1 in the source operand. The source operand can be a memory location or a general-purpose register. The destination operand must be a general-purpose register.	SSE4.2

Summary

In this chapter, you examined the fundamentals of x86-SSE, including its register set, supported packed and scalar data types, and basic processing techniques. You also reviewed the x86-SSE instruction set in order to gain a better understanding of x86-SSE's computational potential. The breadth of x86-SSE's execution environment, data types, and instruction set make it an extremely suitable programming tool for a wide variety of algorithmic problems. In the next four chapters, you'll put your knowledge of X86-SSE to good use by examining a variety of sample programs that expound on material presented in this chapter.



X86-SSE programming – Scalar Floating-Point

In the previous chapter, you explored the computational resources of x86-SSE, including its data types and instruction set. In this chapter, you learn how to perform scalar floating-point arithmetic using the x86-SSE instruction set. The content of this chapter is divided into two sections. The first section illustrates basic x86-SSE scalar floating-point operations, including simple arithmetic, compares, and type conversions. The second section contains a couple of sample programs that demonstrate advanced x86-SSE scalar floating-point techniques.

All of the sample programs in this chapter require a processor that supports SSE2, which includes virtually all AMD and Intel processors marketed since 2003. The documentation header of each assembly language source code listing in this and subsequent x86-SSE programming chapters specifies the minimum version that's required to run the program. Appendix C also lists a couple of freely available utilities that can be used to determine the version of x86-SSE that's supported by the processor in your PC and its operating system.

Scalar Floating-Point Fundamentals

The scalar floating-point capabilities of x86-SSE provides programmers with a modern alternative to the x87 FPU. The ability to directly access the XMM registers means that performing elementary scalar floating-point operations such as addition, subtraction, multiplication, and division is very similar to performing integer arithmetic using the general-purpose registers. Each instruction requires both a source and destination operand and the arithmetic operation that gets performed is `des = des ★ src`, where ★ represents the specific operation. Not having to worry about the state of a register stack improves program readability significantly, which is exemplified by the sample programs of this section.

Scalar Floating-Point Arithmetic

The first x86-SSE scalar floating-point sample program that you examine is called `SseScalarFloatingPointArithmetic`. This program describes how to use the x86-SSE scalar floating-point instruction set to perform basic arithmetic operations using single-precision and double-precision values. The C++ and x86-32 assembly language source code are shown in Listings 8-1 and 8-2.

Listing 8-1. SseScalarFloatingPointArithmetic.cpp

```

#include "stdafx.h"
#define _USE_MATH_DEFINES
#include <math.h>

extern "C" void SseSfpArithmeticFloat_(float a, float b, float c[8]);
extern "C" void SseSfpArithmeticDouble_(double a, double b, double c[8]);

void SseSpfArithmeticFloat(void)
{
    float a = 2.5f;
    float b = -7.625f;
    float c[8];

    SseSfpArithmeticFloat_(a, b, c);
    printf("\nResults for SseSfpArithmeticFloat_()\n");
    printf(" a:          %.6f\n", a);
    printf(" b:          %.6f\n", b);
    printf(" add:        %.6f\n", c[0]);
    printf(" sub:        %.6f\n", c[1]);
    printf(" mul:        %.6f\n", c[2]);
    printf(" div:        %.6f\n", c[3]);
    printf(" min:        %.6f\n", c[4]);
    printf(" max:        %.6f\n", c[5]);
    printf(" fabs(b):    %.6f\n", c[6]);
    printf(" sqrt(fabs(b)): %.6f\n", c[7]);
}

void SseSpfArithmeticDouble(void)
{
    double a = M_PI;
    double b = M_E;
    double c[8];

    SseSfpArithmeticDouble_(a, b, c);
    printf("\nResults for SseSfpArithmeticDouble_()\n");
    printf(" a:          %.14f\n", a);
    printf(" b:          %.14f\n", b);
    printf(" add:        %.14f\n", c[0]);
    printf(" sub:        %.14f\n", c[1]);
    printf(" mul:        %.14f\n", c[2]);
    printf(" div:        %.14f\n", c[3]);
    printf(" min:        %.14f\n", c[4]);
    printf(" max:        %.14f\n", c[5]);
    printf(" fabs(b):    %.14f\n", c[6]);
    printf(" sqrt(fabs(b)): %.14f\n", c[7]);
}

```

```
int _tmain(int argc, _TCHAR* argv[])
{
    SseSpfArithmeticFloat();
    SseSpfArithmeticDouble();
}
```

Listing 8-2. SseScalarFloatingPointArithmetic_.asm

```
.model flat,c
.const

; Mask values for floating-point absolute values
        align 16
AbsMaskFloat    dword 7fffffff,0fffffff,0fffffff,0fffffffh
AbsMaskDouble   qword 7fffffffffffffffh,0xfffffffffffffffh
        .code

; extern "C" void SseSfpArithmeticFloat_(float a, float b, float c[8])
;
; Description: The following function demonstrates basic arithmetic
;              operations using scalar single-precision floating-point
;              values.
;
; Requires     SSE

SseSfpArithmeticFloat_ proc
    push ebp
    mov ebp,esp

; Load argument values
    movss xmm0,real4 ptr [ebp+8]           ;xmm0 = a
    movss xmm1,real4 ptr [ebp+12]        ;xmm1 = b
    mov eax,[ebp+16]                      ;eax = c

; Perform single-precision arithmetic operations
    movss xmm2,xmm0
    addss xmm2,xmm1                       ;xmm2 = a + b
    movss real4 ptr [eax],xmm2

    movss xmm3,xmm0
    subss xmm3,xmm1                       ;xmm3 = a - b
    movss real4 ptr [eax+4],xmm3

    movss xmm4,xmm0
    mulss xmm4,xmm1                       ;xmm4 = a * b
    movss real4 ptr [eax+8],xmm4
```

```

movss xmm5,xmm0
divss xmm5,xmm1           ;xmm5 = a / b
movss real4 ptr [eax+12],xmm5

movss xmm6,xmm0
minss xmm6,xmm1         ;xmm6 = min(a, b)
movss real4 ptr [eax+16],xmm6

movss xmm7,xmm0
maxss xmm7,xmm1         ;xmm7 = max(a, b)
movss real4 ptr [eax+20],xmm7

andps xmm1,[AbsMaskFloat] ;xmm1 = fabs(b)
movss real4 ptr [eax+24],xmm1

sqrtss xmm0,xmm1        ;xmm0 = sqrt(fabs(b))
movss real4 ptr [eax+28],xmm0

pop ebp
ret

```

SseSfpArithmeticFloat_ endp

```

; extern "C" void SseSfpArithmeticDouble_(double a, double b, double c[8])
;
; Description: The following function demonstrates basic arithmetic
;              operations using scalar double-precision floating-point
;              values.
;
; Requires     SSE2

```

SseSfpArithmeticDouble_ proc

```

push ebp
mov ebp,esp

```

; Load argument values

```

movsd xmm0,real8 ptr [ebp+8]   ;xmm0 = a
movsd xmm1,real8 ptr [ebp+16] ;xmm1 = b
mov eax,[ebp+24]               ;eax = c

```

; Perform double-precision arithmetic operations

```

movsd xmm2,xmm0
addsd xmm2,xmm1               ;xmm2 = a + b
movsd real8 ptr [eax],xmm2

movsd xmm3,xmm0
subsd xmm3,xmm1               ;xmm3 = a - b
movsd real8 ptr [eax+8],xmm3

```

```

movsd xmm4,xmm0
mulsd xmm4,xmm1                ;xmm4 = a * b
movsd real8 ptr [eax+16],xmm4

movsd xmm5,xmm0
divsd xmm5,xmm1                ;xmm5 = a / b
movsd real8 ptr [eax+24],xmm5

movsd xmm6,xmm0
minsd xmm6,xmm1                ;xmm6 = min(a, b)
movsd real8 ptr [eax+32],xmm6

movsd xmm7,xmm0
maxsd xmm7,xmm1                ;xmm7 = max(a, b)
movsd real8 ptr [eax+40],xmm7

andpd xmm1,[AbsMaskDouble]     ;xmm1 = fabs(b)
movsd real8 ptr [eax+48],xmm1

sqrtsd xmm0,xmm1               ;xmm0 = sqrt(fabs(b))
movsd real8 ptr [eax+56],xmm0

pop ebp
ret
SseSfpArithmeticDouble_ endp
end

```

The C++ code for sample program `SseScalarFloatingPointArithmetic` (see Listing 8-1) contains a function called `SseSfpArithmeticFloat`, which initializes a couple of single-precision floating-point variables and invokes an x86 assembly language function to perform a variety of basic floating-point arithmetic operations. The assembly language function saves the result of each arithmetic operation to a caller-supplied array. These results are then printed. A similar function named `SseSfpArithmeticDouble` performs the same operations using double-precision values.

The assembly language file `SseScalarFloatingPointArithmetic_.asm` (see Listing 8-2) includes a function named `SseSfpArithmeticFloat_`, which illustrates use the x86-SSE scalar single-precision floating-point instructions. Following the function prolog, a `movss xmm0,real4 ptr [ebp+8]` instruction (Move Scalar Single-Precision Floating-Point Value) copies the argument value `a` to the low-order 32 bits of register XMM0. The high-order bits of XMM0 are not modified by this instruction. The function uses another `movss` instruction to copy argument value `b` into XMM1. It then loads the results array pointer into register EAX.

The code block following register initialization exemplifies use of the scalar single-precision floating-point arithmetic instructions, which should be self-explanatory. Unlike the x87-FPU, there is no x86-SSE scalar floating-point absolute value (`fabs`) instruction. A scalar single-precision floating-point absolute value can easily be calculated using the `andps` (Bitwise Logical AND of Packed Single-Precision Floating-Point Values)

instruction to clear the sign bit. All of the x86-SSE scalar single-precision floating-point arithmetic instructions modify only the low-order 32 bits of the destination XMM register; the high-order bits are not modified. (Note that the `andps` instruction is a packed instruction, which means that the high-order bits of the destination operand are modified.) The result of each arithmetic instruction is saved to the caller-provided array using a `movss` instruction. Proper alignment of a `movss` operand in memory is not required but recommended for performance reasons.

The x86-SSE scalar double-precision floating-point arithmetic instructions are shown in the function `SseSfpArithmeticDouble_`. The logical organization of this function mirrors the single-precision version. When using scalar double-precision floating-point values in an XMM register, only the low-order 64-bits are used; the high-order 64-bits are not modified. Proper alignment of scalar double-precision floating-point operands in memory is also not required but strongly recommended. The results of the `SseScalarFloatingPointArithmetic` sample program are shown in Output 8-1.

Output 8-1. Sample Program `SseScalarFloatingPointArithmetic`

Results for `SseSfpArithmeticFloat_()`

```
a:          2.500000
b:         -7.625000
add:        -5.125000
sub:        10.125000
mul:       -19.062500
div:       -0.327869
min:       -7.625000
max:        2.500000
fabs(b):    7.625000
sqrt(fabs(b)): 2.761340
```

Results for `SseSfpArithmeticDouble_()`

```
a:          3.14159265358979
b:          2.71828182845905
add:        5.85987448204884
sub:        0.42331082513075
mul:        8.53973422267357
div:        1.15572734979092
min:        2.71828182845905
max:        3.14159265358979
fabs(b):    2.71828182845905
sqrt(fabs(b)): 1.64872127070013
```

Scalar Floating-Point Compare

The next x86-SSE scalar floating-point sample program that you'll study is called `SseScalarFloatingPointCompare`. This program shows you how to use the x86-SSE scalar floating-point compare instructions `comiss` and `comisd`. The C++ and x86 assembly language source code for `SseScalarFloatingPointCompare` is shown in Listings 8-3 and 8-4, respectively.

Listing 8-3. SseScalarFloatingPointCompare.cpp

```

#include "stdafx.h"
#include <limits>

using namespace std;

extern "C" void SseSfpCompareFloat_(float a, float b, bool* results);
extern "C" void SseSfpCompareDouble_(double a, double b, bool* results);

const int m = 7;
const char* OpStrings[m] = {"UO", "LT", "LE", "EQ", "NE", "GT", "GE"};

void SseSfpCompareFloat()
{
    const int n = 4;
    float a[n] = {120.0, 250.0, 300.0, 42.0};
    float b[n] = {130.0, 240.0, 300.0, 0.0};

    // Set NAN test value
    b[n - 1] = numeric_limits<float>::quiet_NaN();

    printf("Results for SseSfpCompareFloat()\n");
    for (int i = 0; i < n; i++)
    {
        bool results[m];

        SseSfpCompareFloat_(a[i], b[i], results);
        printf("a: %8f b: %8f\n", a[i], b[i]);

        for (int j = 0; j < m; j++)
            printf(" %s=%d", OpStrings[j], results[j]);
        printf("\n");
    }
}

void SseSfpCompareDouble(void)
{
    const int n = 4;
    double a[n] = {120.0, 250.0, 300.0, 42.0};
    double b[n] = {130.0, 240.0, 300.0, 0.0};

    // Set NAN test value
    b[n - 1] = numeric_limits<double>::quiet_NaN();

```



```

printf("\nResults for SseSfpCompareDouble()\n");
for (int i = 0; i < n; i++)
{
    bool results[m];

    SseSfpCompareDouble_(a[i], b[i], results);
    printf("a: %8lf b: %8lf\n", a[i], b[i]);

    for (int j = 0; j < m; j++)
        printf(" %s=%d", OpStrings[j], results[j]);
    printf("\n");
}
}

int _tmain(int argc, _TCHAR* argv[])
{
    SseSfpCompareFloat();
    SseSfpCompareDouble();
    return 0;
}

```

Listing 8-4. SseScalarFloatingPointCompare_.asm

```

.model flat,c
.code

; extern "C" void SseSfpCompareFloat_(float a, float b, bool* results);
;
; Description: The following function demonstrates use of the comiss
;               instruction.
;
; Requires SSE

SseSfpCompareFloat_ proc
    push ebp
    mov ebp,esp

; Load argument values
    movss xmm0,real4 ptr [ebp+8]           ;xmm0 = a
    movss xmm1,real4 ptr [ebp+12]        ;xmm1 = b
    mov edx,[ebp+16]                     ;edx = results array

; Set result flags based on compare status
    comiss xmm0,xmm1
    setp byte ptr [edx]                   ;EFLAGS.PF = 1 if unordered
    jnp @F
    xor al,al

```

```

    mov byte ptr [edx+1],al           ;Use default result values
    mov byte ptr [edx+2],al
    mov byte ptr [edx+3],al
    mov byte ptr [edx+4],al
    mov byte ptr [edx+5],al
    mov byte ptr [edx+6],al
    jmp Done

@@:  setb byte ptr [edx+1]           ;set byte if a < b
     setbe byte ptr [edx+2]        ;set byte if a <= b
     sete byte ptr [edx+3]        ;set byte if a == b
     setne byte ptr [edx+4]       ;set byte if a != b
     seta byte ptr [edx+5]        ;set byte if a > b
     setae byte ptr [edx+6]       ;set byte if a >= b

Done:  pop ebp
       ret
SseSfpCompareFloat_ endp

; extern "C" void SseSfpCompareDouble_(double a, double b, bool* results);
;
; Description: The following function demonstrates use of the comisd
;              instruction.
;
; Requires     SSE2

SseSfpCompareDouble_ proc
    push ebp
    mov ebp,esp

; Load argument values
    movsd xmm0,real8 ptr [ebp+8]    ;xmm0 = a
    movsd xmm1,real8 ptr [ebp+16]   ;xmm1 = b
    mov edx,[ebp+24]                ;edx = results array

; Set result flags based on compare status
    comisd xmm0,xmm1
    setp byte ptr [edx]             ;EFLAGS.PF = 1 if unordered
    jnp @F
    xor al,al
    mov byte ptr [edx+1],al        ;Use default result values
    mov byte ptr [edx+2],al
    mov byte ptr [edx+3],al
    mov byte ptr [edx+4],al
    mov byte ptr [edx+5],al
    mov byte ptr [edx+6],al
    jmp Done

```

```

@@:      setb byte ptr [edx+1]          ;set byte if a < b
        setbe byte ptr [edx+2]       ;set byte if a <= b
        sete byte ptr [edx+3]        ;set byte if a == b
        setne byte ptr [edx+4]       ;set byte if a != b
        seta byte ptr [edx+5]        ;set byte if a > b
        setae byte ptr [edx+6]       ;set byte if a >= b

Done:    pop ebp
        ret
SseSfpCompareDouble_ endp
        end

```

The logical organization of `SseScalarFloatingPointCompare.cpp` (see Listing 8-2) is similar to the previous sample program. It also contains two functions that initialize test cases for scalar single-precision and double-precision floating-point values. Note that each test array pair includes a NaN value in order to verify proper handling of an unordered compare. The C++ code also contains statements that display the results of each test case.

The assembly language code in `SseScalarFloatingPointCompare_.asm` (see Listing 8-4) includes separate single-precision and double-precision functions. Following its prolog, function `SseSfpCompareFloat_` uses a `movss` instruction to load argument values `a` and `b` into registers `XMM0` and `XMM1`, respectively. It then loads a pointer to the results array into register `EDX`. The `comiss xmm0, xmm1` (Compare Scalar Ordered Single-Precision Floating-Point Values and Set EFLAGS) instruction compares the scalar single-precision floating-point values in registers `XMM0` and `XMM1`. This instruction sets status bits in the EFLAGS register to report its results as outlined in Table 8-1. Note that the condition codes shown in this table are the same as the ones used by the x87 FPU `f(u)comi(p)` instructions, which were discussed in Chapter 4.

Table 8-1. EFLAG Results for `comiss` and `comisd` Instructions

Relational Operator	Condition Code (for <code>jcc</code> or <code>setcc</code>)	EFLAGS Test
<code>XMM0 < XMM1</code>	<code>b</code>	<code>CF == 1</code>
<code>XMM0 <= XMM1</code>	<code>be</code>	<code>CF == 1 ZF == 1</code>
<code>XMM0 == XMM1</code>	<code>z</code>	<code>ZF == 1</code>
<code>XMM0 != XMM1</code>	<code>nz</code>	<code>ZF == 0</code>
<code>XMM0 > XMM1</code>	<code>a</code>	<code>CF == 0 && ZF == 0</code>
<code>XMM0 >= XMM1</code>	<code>ae</code>	<code>CF == 0</code>

The `SseSfpCompareFloat_` function uses a series of `setcc` instructions to decode and save the results of the compare operation. Note that if register `XMM0` or `XMM1` contains an unordered floating-point value, the status bit `EFLAGS.PF` is set and the function will assign each Boolean flag in the results array to `false`. It is also possible to use a conditional jump instruction following a `comiss` or `comisd` instruction. The function `SseSfpCompareDouble_` is virtually identical to `SseSfpCompareFloat_` except for the use of `movsd` instead of `movss`, `comisd` instead of `comiss`, and stack offsets that are appropriate for scalar double-precision floating-point values. Output 8-2 shows the results of the `SseScalarFloatingPointCompare` sample program.

Output 8-2. Sample Program `SseScalarFloatingPointCompare`

```
Results for SseSfpCompareFloat()
a: 120.000000 b: 130.000000
  U0=0 LT=1 LE=1 EQ=0 NE=1 GT=0 GE=0
a: 250.000000 b: 240.000000
  U0=0 LT=0 LE=0 EQ=0 NE=1 GT=1 GE=1
a: 300.000000 b: 300.000000
  U0=0 LT=0 LE=1 EQ=1 NE=0 GT=0 GE=1
a: 42.000000 b: 1.#QNANO
  U0=1 LT=0 LE=0 EQ=0 NE=0 GT=0 GE=0
```

```
Results for SseSfpCompareDouble()
a: 120.000000 b: 130.000000
  U0=0 LT=1 LE=1 EQ=0 NE=1 GT=0 GE=0
a: 250.000000 b: 240.000000
  U0=0 LT=0 LE=0 EQ=0 NE=1 GT=1 GE=1
a: 300.000000 b: 300.000000
  U0=0 LT=0 LE=1 EQ=1 NE=0 GT=0 GE=1
a: 42.000000 b: 1.#QNANO
  U0=1 LT=0 LE=0 EQ=0 NE=0 GT=0 GE=0
```

Scalar Floating-Point Conversions

X86-SSE includes a number of instructions that perform conversions between different data types. For example, a common operation in many C++ programs is to convert a floating-point value to an integer or vice versa. The sample program `SseScalarFloatingPointConversions` demonstrates how to use the x86-SSE conversion instructions to perform this type of operation. It also illustrates how to modify the rounding control field of the `MXCSR` register in order to change the x86-SSE floating-point rounding mode. Listings 8-5 and 8-6 contain the C++ and x86-32 assembly language source code, respectively, for the `SseScalarFloatingPointConversions` sample program.

Listing 8-5. SseScalarFloatingPointConversions.cpp

```

#include "stdafx.h"
#define _USE_MATH_DEFINES
#include <math.h>
#include "MiscDefs.h"

// Simple union for data exchange
union XmmScalar
{
    float r32;
    double r64;
    UInt32 i32;
    UInt64 i64;
};

// The order of values below must match the jump table
// that's defined in SseScalarFloatingPointConversions_.asm.
enum CvtOp : unsigned int
{
    Cvtsi2ss,      // Int32 to float
    Cvtss2si,     // float to Int32
    Cvtsi2sd,     // Int32 to double
    Cvtsd2si,     // double to Int32
    Cvtss2sd,     // float to double
    Cvtsd2ss,     // double to float
};

// Enumerated type for x86-SSE rounding mode
enum SseRm : unsigned int
{
    Nearest, Down, Up, Truncate
};

extern "C" UInt32 SseGetMxcsr_(void);
extern "C" UInt32 SseSetMxcsr_(UInt32 mxcsr);

extern "C" SseRm SseGetMxcsrRoundingMode_(void);
extern "C" void SseSetMxcsrRoundingMode_(SseRm rm);
extern "C" bool SseSfpConversion_(XmmScalar* a, XmmScalar* b, CvtOp cvt_op);

const SseRm SseRmVals[] = {SseRm::Nearest, SseRm::Down, SseRm::Up,
SseRm::Truncate};
const char* SseRmStrings[] = {"Nearest", "Down", "Up", "Truncate"};

```

```

void SseSfpConversions(void)
{
    XmmScalar src1, src2;
    XmmScalar des1, des2;
    const int num_rm = sizeof(SseRmVals) / sizeof (SseRm);
    Uint32 mxcsr_save = SseGetMxcsr_();

    src1.r32 = (float)M_PI;
    src2.r64 = -M_E;

    for (int i = 0; i < num_rm; i++)
    {
        SseRm rm1 = SseRmVals[i];
        SseRm rm2;

        SseSetMxcsrRoundingMode_(rm1);
        rm2 = SseGetMxcsrRoundingMode_();

        if (rm2 != rm1)
        {
            printf(" SSE rounding mode change failed\n");
            printf(" rm1: %d rm2: %d\n", rm1, rm2);
        }
        else
        {
            printf("X86-SSE rounding mode = %s\n", SseRmStrings[rm2]);

            SseSfpConversion_(&des1, &src1, CvtOp::Cvtss2si);
            printf(" cvtss2si: %12lf --> %6d\n", src1.r32, des1.i32);

            SseSfpConversion_(&des2, &src2, CvtOp::Cvttd2si);
            printf(" cvtsd2si: %12lf --> %6d\n", src2.r64, des2.i32);
        }
    }

    SseSetMxcsr_(mxcsr_save);
}

int _tmain(int argc, _TCHAR* argv[])
{
    SseSfpConversions();
    return 0;
}

```

Listing 8-6. SseScalarFloatingPointConversions_.asm

```

.model flat,c
.code

; extern "C" bool SseSfpConversion_(XmmScalar* des, const XmmScalar* src,
CvtOp cvt_op)
;
; Description: The following function demonstrates use of the x86-SSE
;               scalar floating-point conversion instructions.
;
; Requires:     SSE2

SseSfpConversion_ proc
    push ebp
    mov ebp,esp

; Load argument values and make sure cvt_op is valid
    mov eax,[ebp+16]           ;cvt_op
    mov ecx,[ebp+12]         ;ptr to src
    mov edx,[ebp+8]          ;ptr to des
    cmp eax,CvtOpTableCount
    jae BadCvtOp             ;jump if cvt_op is invalid
    jmp [CvtOpTable+eax*4]   ;jump to specified conversion

SseCvtSi2Ss:
    mov eax,[ecx]            ;load integer value
    cvtsi2ss xmm0,eax        ;convert to float
    movss real4 ptr [edx],xmm0 ;save result
    mov eax,1
    pop ebp
    ret

SseCvtSs2Si:
    movss xmm0,real4 ptr [ecx] ;load float value
    cvtss2si eax,xmm0         ;convert to integer
    mov [edx],eax            ;save result
    mov eax,1
    pop ebp
    ret

SseCvtSi2Sd:
    mov eax,[ecx]           ;load integer value
    cvtsi2sd xmm0,eax       ;convert to double
    movsd real8 ptr [edx],xmm0 ;save result
    mov eax,1
    pop ebp
    ret

```

```

SseCvt2sd2si:
    movsd xmm0,real8 ptr [ecx]           ;load double value
    cvtsd2si eax,xmm0                   ;convert to integer
    mov [edx],eax                        ;save result
    mov eax,1
    pop ebp
    ret

SseCvtss2sd:
    movss xmm0,real4 ptr [ecx]           ;load float value
    cvtss2sd xmm1,xmm0                  ;convert to double
    movsd real8 ptr [edx],xmm1          ;save result
    mov eax,1
    pop ebp
    ret

SseCvt2sd2ss:
    movsd xmm0,real8 ptr [ecx]           ;load double value
    cvtsd2ss xmm1,xmm0                  ;convert to float
    movss real4 ptr [edx],xmm1          ;save result
    mov eax,1
    pop ebp
    ret

BadCvtOp:
    xor eax,eax                          ;set error return code
    pop ebp
    ret

```

; The order of values in following table must match the enum CvtOp
; that's defined in SseScalarFloatingPointConversions.cpp

```

    align 4
CvtOpTable  dword SseCvt2si2ss, SseCvtss2si
            dword SseCvt2si2sd, SseCvt2sd2si
            dword SseCvtss2sd, SseCvt2sd2ss
CvtOpTableCount equ ($ - CvtOpTable) / size dword
SseSfpConversion_ endp

```

```

; extern "C" Uint32 SseGetMxcsr_(void);
;
; Description: The following function obtains the current contents of
;             the MXCSR register.
;
; Returns:    Contents of MXCSR

```



```

SseGetMxcsr_ proc
    push ebp
    mov ebp,esp
    sub esp,4

    stmxcsr [ebp-4]                ;save mxcsr register
    mov eax,[ebp-4]                ;move to eax for return

    mov esp,ebp
    pop ebp
    ret
SseGetMxcsr_ endp

; extern "C" Uint32 SseSetMxcsr_(Uint32 mxcsr);
;
; Description: The following function loads a new value into the
;              MXCSR register.

SseSetMxcsr_ proc
    push ebp
    mov ebp,esp
    sub esp,4

    mov eax,[ebp+8]                ;eax = new mxcsr value
    and eax,0ffffh                ;bits mxcsr[31:16] must be 0
    mov [ebp-4],eax
    ldmxcsr [ebp-4]                ;load mxcsr register

    mov esp,ebp
    pop ebp
    ret
SseSetMxcsr_ endp

; extern "C" SseRm SseGetMxcsrRoundingMode_(void);
;
; Description: The following function obtains the current x86-SSE
;              floating-point rounding mode from MXCSR.RC.
;
; Returns:     Current x86-SSE rounding mode.

MxcsrRcMask equ 9ffffh            ;bit pattern for MXCSR.RC
MxcsrRcShift equ 13               ;shift count for MXCSR.RC

SseGetMxcsrRoundingMode_ proc
    push ebp
    mov ebp,esp
    sub esp,4

```

```

    stmxcsr [ebp-4]                ;save mxcsr register
    mov eax,[ebp-4]
    shr eax,MxcsrRcShift          ;eax[1:0] = MXCSR.RC bits
    and eax,3                     ;masked out unwanted bits

    mov esp,ebp
    pop ebp
    ret
SseGetMxcsrRoundingMode_ endp

;extern "C" void SseSetMxcsrRoundingMode_(SseRm rm);
;
; Description: The following function updates the rounding mode
;              value in MXCSR.RC.

SseSetMxcsrRoundingMode_ proc
    push ebp
    mov ebp,esp
    sub esp,4

    mov ecx,[ebp+8]               ;ecx = rm
    and ecx,3                     ;masked out unwanted bits
    shl ecx,MxcsrRcShift         ;ecx[14:13] = rm

    stmxcsr [ebp-4]              ;save current MXCSR
    mov eax,[ebp-4]
    and eax,MxcsrRcMask          ;masked out old MXCSR.RC bits
    or eax,ecx                   ;insert new MXCSR.RC bits
    mov [ebp-4],eax
    ldmxcsr [ebp-4]              ;load updated MXCSR

    mov esp,ebp
    pop ebp
    ret
SseSetMxcsrRoundingMode_ endp
end

```

Near the top of `SseScalarFloatingPointConversions.cpp` (see Listing 8-5) is a declaration for a C++ union named `XmmScalar`, which is used by the sample program for data exchange purposes. This is followed by two enumerations: one to select a floating-point conversion type (`CvtOp`) and another to specify an x86-SSE floating-point rounding mode (`SseRm`). The C++ function `SseSfpConversions` initializes a couple of `XmmScalar` instances as test values and invokes an x86 assembly language function to perform floating-point to integer conversions using different rounding modes. The result of each conversion operation is displayed for verification and comparison purposes.

The x86-SSE floating-point rounding mode is determined by the rounding control field (bits 14 and 13) of register MXCSR. The default rounding mode for Visual C++ programs is round to nearest. According to the Visual C++ calling convention, the default values in MXCSR[15:6] (i.e., MXCSR register bits 15 through 6) must be preserved across most function boundaries. The function `SseSfpConversions` fulfills this requirement by saving the contents of MXCSR prior to changing the x86-SSE rounding mode. It also restores the original contents of MXCSR before exiting.

The assembly language file `SseScalarFloatingPointConversions.asm` (see Listing 8-6) contains the conversion and MXCSR control functions. The function `SseSfpConversion_` performs floating-point conversions using the specified values and conversion operator. This function uses a jump table similar to what you've already seen in previous sample programs. The assembly language file `SseScalarFloatingPointConversions_.asm` also contains several MXCSR management methods. The functions `SseGetMxcsr_` and `SseSetMxcsr_` are employed to perform reads and writes of the MXCSR register. These functions use the `stmxcsr` (Store MXCSR Register State) and `ldmxcsr` (Load MXCSR Register) instructions, respectively. Both `stmxcsr` and `ldmxcsr` require their sole operand to be a doubleword value in memory. The functions `SseGetMxcsrRoundingMode_` and `SseSetMxcsrRoundingMode_` can be used to change the current x86-SSE floating-point rounding mode. These functions exercise the enumeration `SseRm` to save or select an x86-SSE floating-point rounding mode.

Conversions between two different numerical data types are not always possible. For example, the `cvtss2si` instruction is unable to convert large floating-point values to signed doubleword integers. If a particular conversion is impossible and invalid operation exceptions (MXCSR.IM) are masked (the default for Visual C++), the processor sets MXCSR.IE (Invalid Operation Error Flag) and the value `0x80000000` is copied to the destination operand. Output 8-3 contains the results of the `SseScalarFloatingPointConversions` sample program.

Output 8-3. Sample Program `SseScalarFloatingPointConversions`

```
X86-SSE rounding mode = Nearest
  cvtss2si:    3.141593 -->    3
  cvtsd2si:   -2.718282 -->   -3
X86-SSE rounding mode = Down
  cvtss2si:    3.141593 -->    3
  cvtsd2si:   -2.718282 -->   -3
X86-SSE rounding mode = Up
  cvtss2si:    3.141593 -->    4
  cvtsd2si:   -2.718282 -->   -2
X86-SSE rounding mode = Truncate
  cvtss2si:    3.141593 -->    3
  cvtsd2si:   -2.718282 -->   -2
```

Advanced Scalar Floating-Point Programming

The sample programs in this section demonstrate how to use the x86-SSE scalar floating-point instruction set to perform advanced computations. The first sample program is a rehash of an earlier program that highlights key differences between the original x87 FPU and x86-SSE. In the second sample program, you learn how to exploit data structures and standard C++ library functions in an assembly language function that uses x86-SSE instructions.

Scalar Floating-Point Spheres

Now that you're acquainted with the scalar floating-point capabilities of x86-SSE, it's time to examine some code that performs practical calculations. The sample program that you study in this section is called `SseScalarFloatingPointSpheres`. This program contains an assembly language function that calculates the surface area and volume of a sphere using the scalar floating-point instructions of x86-SSE. You may recall that Chapter 4 included a sample program that calculated the surface area and volume of a sphere using the x87 FPU instruction set. The refactoring of the sphere area-volume code from x87 FPU to x86-SSE is carried out in order to emphasize how much easier the latter is to create. Listings 8-7 and 8-8 show the source code for the C++ and assembly language files `SseScalarFloatingPointSpheres.cpp` and `ScalarFloatingPointSpheres.asm`, respectively.

Listing 8-7. `SseScalarFloatingPointSpheres.cpp`

```
#include "stdafx.h"

extern "C" bool SseSfpCalcSphereAreaVolume_(double r, double* sa, double* v);

int _tmain(int argc, _TCHAR* argv[])
{
    const double r[] = {-1.0, 0.0, 1.0, 2.0, 3.0, 5.0, 10.0, 20.0};
    int num_r = sizeof(r) / sizeof(double);

    for (int i = 0; i < num_r; i++)
    {
        double sa, v;
        bool rc = SseSfpCalcSphereAreaVolume_(r[i], &sa, &v);

        printf("rc: %d r: %8.2lf sa: %10.4lf vol: %10.4lf\n", rc, r[i],
sa, v);
    }

    return 0;
}
```

Listing 8-8. SseScalarFloatingPointSpheres_.asm

```

.model flat,c

; Constants required to calculate sphere surface area and volume.
.const
r8_pi      real8 3.14159265358979323846
r8_four    real8 4.0
r8_three   real8 3.0
r8_neg_one real8 -1.0
.code

; extern "C" bool SseSfpCalcSphereAreaVolume_(double r, double* sa, double* v);
;
; Description: The following function calculates the surface area and
;              volume of a sphere.
;
; Returns:     0 = invalid radius
;              1 = success
;
; Requires:    SSE2

SseSfpCalcSphereAreaVolume_ proc
    push ebp
    mov  ebp,esp

; Load arguments and make sure radius is valid
    movsd xmm0,real8 ptr [ebp+8]      ;xmm0 = r
    mov  ecx,[ebp+16]                 ;ecx = sa
    mov  edx,[ebp+20]                 ;edx = v
    xorpd xmm7,xmm7                  ;xmm7 = 0.0
    comisd xmm0,xmm7                  ;compare r against 0.0
    jp   BadRadius                   ;jump if r is NAN
    jb   BadRadius                   ;jump if r < 0.0

; Compute the surface area
    movsd xmm1,xmm0                   ;xmm1 = r
    mulsd xmm1,xmm1                   ;xmm1 = r * r
    mulsd xmm1,[r8_four]              ;xmm1 = 4 * r * r
    mulsd xmm1,[r8_pi]                ;xmm1 = 4 * pi r * r
    movsd real8 ptr [ecx],xmm1        ;save surface area

```

```

; Compute the volume
    mulsd xmm1,xmm0           ;xmm1 = 4 * pi * r * r * r
    divsd xmm1,[r8_three]     ;xmm1 = 4 * pi * r * r * r / 3
    movsd real8 ptr [edx],xmm1 ;save volume
    mov eax,1                 ;set success return code
    pop ebp
    ret

; Invalid radius - set surface area and volume to -1.0
BadRadius:
    movsd xmm0,[r8_neg_one]   ;xmm0 = -1.0
    movsd real8 ptr [ecx],xmm0 ;*sa = -1.0
    movsd real8 ptr [edx],xmm0 ;*v = -1.0;
    xor eax,eax               ;set error return code
    pop ebp
    ret
SseSfpCalcSphereAreaVolume_ endp
end

```

The C++ portion of project `SseScalarFloatingPointSpheres` (see Listing 8-7) contains some simple code that exercises the assembly language function `SseSfpCalcSphereAreaVolume_` using different test values for the radius. Following its prolog, the function `SseSfpCalcSphereAreaVolume_` (see Listing 8-8) loads argument values `r`, `sa`, and `v` into registers `XMM0`, `ECX`, and `EDX`, respectively. A `comisd xmm0,xmm7` instruction compares the value of `r` against 0.0 and uses status bits in `EFLAGS` to indicate the results. Unlike the x87 FPU, the x86-SSE instruction set does not support load-constant instructions such as `fldz` and `fldpi`. All floating-point constants must be loaded from memory or computed using available x86-SSE instructions, which explains why an `xorpd (Bitwise Logical XOR for Double-Precision Floating-Point Values)` instruction is used before `comisd`. Two conditional jump instructions, `jp` and `jb`, are employed to prevent the function from using an invalid radius value during calculation of the surface area and volume.

Computation of the surface area occurs next and is carried out using the `mulsd` instruction. This is followed by a section of code that calculates the sphere's volume using `mulsd` and `divsd`. The function `SseSfpCalcSphereAreaVolume_` is a good example of how much simpler it is to perform scalar floating-point arithmetic using the x86-SSE vs. the x87 FPU instruction set. Output 8-4 shows the results of the `SseScalarFloatingPointSpheres` sample program.

Output 8-4. Sample Program `SseScalarFloatingPointSpheres`

```

rc: 0 r:   -1.00 sa:   -1.0000 vol:   -1.0000
rc: 1 r:    0.00 sa:    0.0000 vol:    0.0000
rc: 1 r:    1.00 sa:   12.5664 vol:    4.1888
rc: 1 r:    2.00 sa:   50.2655 vol:   33.5103
rc: 1 r:    3.00 sa:  113.0973 vol:  113.0973
rc: 1 r:    5.00 sa:  314.1593 vol:  523.5988
rc: 1 r:   10.00 sa: 1256.6371 vol: 4188.7902
rc: 1 r:   20.00 sa: 5026.5482 vol: 33510.3216

```

Scalar Floating-Point Parallelograms

The final scalar floating-point sample program of this chapter is called `SseScalarFloatingPointParallelograms`. This program demonstrates how to use x86-SSE scalar floating-point instruction set to calculate the area and diagonal lengths of a parallelogram using its side lengths and one angle measurement. It also illustrates how to invoke a C++ library routine from an assembly language function that exercises x86-SSE instructions. The C++ and assembly language files for sample program `SseScalarFloatingPointParallelograms` are shown in Listings 8-9 and 8-10, respectively.

Listing 8-9. `SseScalarFloatingPointParallelograms.cpp`

```
#include "stdafx.h"
#define _USE_MATH_DEFINES
#include <math.h>
#include <stddef.h>

// Uncomment line below to enable display of PDATA information
// #define DISPLAY_PDATA_INFO

// This structure must agree with the structure that's defined
// in file SseScalarFloatingPointParallelograms.asm.
typedef struct
{
    double A;           // Length of left and right
    double B;           // Length of top and bottom
    double Alpha;       // Angle alpha in degrees
    double Beta;        // Angle beta in degrees
    double H;           // Height of parallelogram
    double Area;        // Parallelogram area
    double P;           // Length of diagonal P
    double Q;           // Length of diagonal Q
    bool BadValue;      // Set to true if A, B, or Alpha is invalid
    char Pad[7];        // Reserved for future use
} PDATA;

extern "C" bool SseSfpParallelograms_(PDATA* pdata, int n);
extern "C" double DegToRad = M_PI / 180.0;
extern "C" int SizeofPdataX86_;
const bool PrintPdataInfo = true;

void SetPdata(PDATA* pdata, double a, double b, double alpha)
{
    pdata->A = a;
    pdata->B = b;
    pdata->Alpha = alpha;
}
```

```

int _tmain(int argc, _TCHAR* argv[])
{
#ifdef DISPLAY_PDATA_INFO
    size_t spd1 = sizeof(PDATA);
    size_t spd2 = SizeofPdataX86_;

    if (spd1 != spd2)
        printf("PDATA size discrepancy [%d, %d]", spd1, spd2);
    else
    {
        printf("sizeof(PDATA):      %d\n", spd1);
        printf("Offset of A:          %d\n", offsetof(PDATA, A));
        printf("Offset of B:          %d\n", offsetof(PDATA, B));
        printf("Offset of Alpha:       %d\n", offsetof(PDATA, Alpha));
        printf("Offset of Beta:       %d\n", offsetof(PDATA, Beta));
        printf("Offset of H           %d\n", offsetof(PDATA, H));
        printf("Offset of Area:      %d\n", offsetof(PDATA, Area));
        printf("Offset of P:         %d\n", offsetof(PDATA, P));
        printf("Offset of Q:         %d\n", offsetof(PDATA, Q));
        printf("Offset of BadValue  %d\n", offsetof(PDATA, BadValue));
        printf("Offset of Pad       %d\n", offsetof(PDATA, Pad));
    }
#endif

    const int n = 10;
    PDATA pdata[n];

    // Create some test parallelograms
    SetPdata(&pdata[0], -1.0, 1.0, 60.0);
    SetPdata(&pdata[1], 1.0, -1.0, 60.0);
    SetPdata(&pdata[2], 1.0, 1.0, 181.0);
    SetPdata(&pdata[3], 1.0, 1.0, 90.0);
    SetPdata(&pdata[4], 3.0, 4.0, 90.0);
    SetPdata(&pdata[5], 2.0, 3.0, 30.0);
    SetPdata(&pdata[6], 3.0, 2.0, 60.0);
    SetPdata(&pdata[7], 4.0, 2.5, 120.0);
    SetPdata(&pdata[8], 5.0, 7.125, 135.0);
    SetPdata(&pdata[9], 8.0, 8.0, 165.0);

    SseSfpParallelograms_(pdata, n);

    for (int i = 0; i < n; i++)
    {
        PDATA* p = &pdata[i];
        printf("\npdata[%d] - BadValue = %d\n", i, p->BadValue);
        printf("A: %12.6lf B: %12.6lf\n", p->A, p->B);
    }
}

```



```

        printf("Alpha: %12.6lf Beta: %12.6lf\n", p->Alpha, p->Beta);
        printf("H: %12.6lf Area: %12.6lf\n", p->H, p->Area);
        printf("P: %12.6lf Q: %12.6lf\n", p->P, p->Q);
    }

    return 0;
}

```

Listing 8-10. SseScalarFloatingPointParellelograms_.asm

```

        .model flat,c

; This structure must agree with the structure that's defined
; in file SseScalarFloatingPointParallelograms.cpp
PDATA struct
A        real8 ?
B        real8 ?
Alpha   real8 ?
Beta    real8 ?
H        real8 ?
Area    real8 ?
P        real8 ?
Q        real8 ?
BadVal  byte ?
Pad     byte 7 dup(?)
PDATA  ends

; Constant values used by function
        .const
        public SizeofPdataX86_
r8_2p0    real8 2.0
r8_180p0  real8 180.0
r8_MinusOne real8 -1.0
SizeofPdataX86_ dword size PDATA

        .code
        extern sin:proc, cos:proc
        extern DegToRad:real8

; extern "C" bool SseSfpParallelograms_(PDATA* pdata, int n);
;
; Description: The following function calculates area and length
;              values for parallelograms.
;
; Returns:     0   n <= 0
;              1   n > 0
;

```

```

; Local stack: [ebp-8]      x87 FPU transfer location
;               [ebp-16]   Alpha in radians
;
; Requires SSE2

SseSfpParallelograms_proc
    push ebp
    mov  ebp,esp
    sub  esp,16                ;allocate space for local vars
    push ebx

; Load arguments and validate n
    xor  eax,eax                ;set error code
    mov  ebx,[ebp+8]           ;ebx = pdata
    mov  ecx,[ebp+12]         ;ecx = n
    test ecx,ecx
    jle  Done                  ;jump if n <= 0

; Initialize constant values
Loop1: movsd xmm6,real8 ptr [r8_180p0] ;xmm6 = 180.0
       xorpd xmm7,xmm7          ;xmm7 = 0.0
       sub  esp,8              ;space for sin/cos arg value

; Load and validate A and B
    movsd xmm0,real8 ptr [ebx+PDATA.A] ;xmm0 = A
    movsd xmm1,real8 ptr [ebx+PDATA.B] ;xmm1 = B
    comisd xmm0,xmm7
    jp   InvalidValue
    jbe  InvalidValue          ;jump if A <= 0.0
    comisd xmm1,xmm7
    jp   InvalidValue
    jbe  InvalidValue          ;jump if B <= 0.0

; Load and validate Alpha
    movsd xmm2,real8 ptr [ebx+PDATA.Alpha]
    comisd xmm2,xmm7
    jp   InvalidValue
    jbe  InvalidValue          ;jump if Alpha <= 0.0
    comisd xmm2,xmm6
    jae  InvalidValue          ;jump if Alpha >= 180.0

; Compute Beta
    subsd xmm6,xmm2            ;Beta = 180.0 - Alpha
    movsd real8 ptr [ebx+PDATA.Beta],xmm6 ;Save Beta

```

```

; Compute sin(Alpha)
    mulsd xmm2,real8 ptr [DegToRad]           ;convert Alpha to radians
    movsd real8 ptr [ebp-16],xmm2           ;save value for later
    movsd real8 ptr [esp],xmm2             ;copy Alpha onto stack
    call sin
    fstp real8 ptr [ebp-8]                   ;save sin(Alpha)

; Compute parallelogram Height and Area
    movsd xmm0,real8 ptr [ebx+PDATA.A]      ;A
    mulsd xmm0,real8 ptr [ebp-8]           ;A * sin(Alpha)
    movsd real8 ptr [ebx+PDATA.H],xmm0     ;save height
    mulsd xmm0,real8 ptr [ebx+PDATA.B]     ;A * sin(Alpha) * B
    movsd real8 ptr [ebx+PDATA.AREA],xmm0  ;save area

; Compute cos(Alpha)
    movsd xmm0,real8 ptr [ebp-16]         ;xmm0 = Alpha in radians
    movsd real8 ptr [esp],xmm0           ;copy Alpha onto stack
    call cos
    fstp real8 ptr [ebp-8]                 ;save cos(Alpha)

; Compute 2.0 * A * B * cos(Alpha)
    movsd xmm0,real8 ptr [r8_2p0]
    movsd xmm1,real8 ptr [ebx+PDATA.A]
    movsd xmm2,real8 ptr [ebx+PDATA.B]
    mulsd xmm0,xmm1                       ;2 * A
    mulsd xmm0,xmm2                       ;2 * A * B
    mulsd xmm0,real8 ptr [ebp-8]         ;2 * A * B * cos(Alpha)

; Compute A * A + B * B
    movsd xmm3,xmm1                       ;A * A
    movsd xmm4,xmm2                       ;B * B
    mulsd xmm3,xmm3                       ;A * A
    mulsd xmm4,xmm4                       ;B * B
    addsd xmm3,xmm4                       ;A * A + B * B
    movsd xmm4,xmm3                       ;A * A + B * B

; Compute P and Q
    subsd xmm3,xmm0                       ;xmm3 = P
    sqrtsd xmm3,xmm3
    movsd real8 ptr [ebx+PDATA.P],xmm3
    addsd xmm4,xmm0
    sqrtsd xmm4,xmm4                       ;xmm4 = Q
    movsd real8 ptr [ebx+PDATA.Q],xmm4
    mov dword ptr [ebx+PDATA.BadVal],0    ;set BadVal to false

```

```

NextItem:
    add ebx,size PDATA                ;ebx = next element in array
    dec ecx
    jnz Loop1                        ;repeat loop until done

    add esp,8                        ;restore ESP
Done:  pop ebx
       mov esp,ebp
       pop ebp
       ret

; Set structure members to know values for display purposes
InvalidValue:
    movsd xmm0,real8 ptr [r8_MinusOne]
    movsd real8 ptr [ebx+PDATA.Beta],xmm0
    movsd real8 ptr [ebx+PDATA.H],xmm0
    movsd real8 ptr [ebx+PDATA.Area],xmm0
    movsd real8 ptr [ebx+PDATA.P],xmm0
    movsd real8 ptr [ebx+PDATA.Q],xmm0
    mov dword ptr [ebx+PDATA.BadVal],1
    jmp NextItem

SseSfpParallelograms_ endp
    end

```

Before examining the source code for the sample program `SseScalarFloatingPointParallelograms`, let's review some basic parallelogram geometry. Figure 8-1 illustrates a standard parallelogram. This figure (as well as the source code) uses the letter *A* to represent the length of the left and right sides; *B* to denote the length of the top and bottom sides; *H* to indicate the height; α and β to signify the left and right angles; and the letters *P* and *Q* to symbolize the lengths of the diagonals.

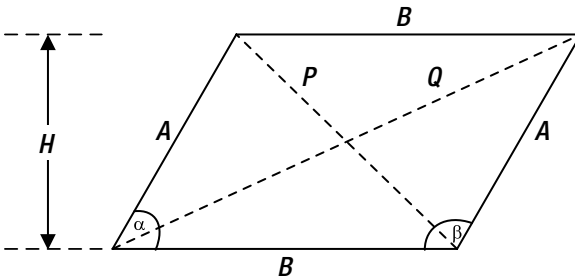

Figure 8-1. Illustration of a standard parallelogram

The values of H , β , P , and Q can be derived from A , B , and α using the following formulas:

$$\beta = 180 - \alpha \quad H = A \sin(\alpha) \quad Area = AB \sin(\alpha)$$

$$P = \sqrt{A^2 + B^2 - 2AB \cos(\alpha)} \quad Q = \sqrt{A^2 + B^2 + 2AB \cos(\alpha)}$$

The sample program `SseScalarFloatingPointParallelograms` employs a structure to help manage the parallelogram parameters. The C++ version of this structure is named `PDATA` and is declared near the top of source file `SseScalarFloatingPointParallelograms.cpp` (see Listing 8-9). When declaring a C++ structure that contains more than a few items, it is often helpful to know the offset of each structure item in order to confirm congruence with the assembly language version. The block of code near the top of function `_tmain` can be enabled by defining a C++ preprocessor named `DISPLAY_PDATA_INFO`. It is also important to verify size equality of the C++ and assembly language versions of structure `PDATA` given that the assembly language function `SseSfpParallelograms_` processes an array of `PDATA` items.

Near the top of file `SseScalarFloatingPointParallelograms.asm` (see Listing 8-10) is the assembly language version of structure `PDATA`. Keep in mind that unlike the C++ compiler, the assembler does not automatically align structure members to their natural boundaries. It is often necessary to add padding bytes to an assembly language structure in order to achieve equivalence with its C++ counterpart. The assembly language function `SseSfpParallelograms_` uses a processing loop to compute the required values for each parallelogram. The `sub esp, 8` statement near the label `Loop1` creates space on the stack for a double-precision floating-point function argument that's used later. During each iteration, the processing loop begins by validating the parallelogram values A , B , and α using a series of `comisd` and conditional jump instructions. If these values are valid, it then calculates and saves the value of angle β .

The next computation is the calculation of $\sin(\alpha)$, which opens with the conversion of α from degrees to radians. A `movsd real8 ptr [ebp-16], xmm2` instruction saves the converted angle value in a local stack variable for later use. The angle value is also saved on the stack using a `movsd real8 ptr [esp], xmm2` instruction. This is followed by a `call sin` instruction, which computes the sine of α using the C++ library function. Unlike the x87 FPU, x86-SSE does not include transcendental instructions such as `fsin` and `fcos`. The return value from function `sin` is saved on the x87 FPU register stack per the Visual C++ calling convention. A `fstp real8 ptr [ebp-8]` instruction copies $\sin(\alpha)$ to a local stack variable and removes this value from the x87 FPU register stack. It is important to note that the Visual C++ calling convention for 32-bit programs treats all XMM registers as volatile, which means that no assumptions can be made about the values in XMM0-XMM7 following execution of the function `sin` or any other library function.

Following calculation of $\sin(\alpha)$, the parallelogram's area and height are computed and saved to the instance of `PDATA` pointed to by `EBX`. Calculation of $\cos(\alpha)$ occurs next using the C++ library function `cos`. Finally, the lengths of P and Q are calculated. Note that the common sub-expressions required for both P and Q are computed only once. All loop variables are updated in the code block following the label `NextItem`. Subsequent to the completion of the processing loop, an `add esp, 8` instruction restores register `ESP` to its proper value before the function epilog. The results of `SseScalarFloatingPointParallelograms` are shown in Output 8-5.

Output 8-5. Sample Program SseScalarFloatingPointParallelograms

```
pdata[0] - BadValue = 1
A:      -1.000000  B:      1.000000
Alpha:   60.000000  Beta:   -1.000000
H:       -1.000000  Area:   -1.000000
P:       -1.000000  Q:     -1.000000
```

```
pdata[1] - BadValue = 1
A:       1.000000  B:     -1.000000
Alpha:   60.000000  Beta:   -1.000000
H:       -1.000000  Area:   -1.000000
P:       -1.000000  Q:     -1.000000
```

```
pdata[2] - BadValue = 1
A:       1.000000  B:      1.000000
Alpha:  181.000000  Beta:   -1.000000
H:       -1.000000  Area:   -1.000000
P:       -1.000000  Q:     -1.000000
```

```
pdata[3] - BadValue = 0
A:       1.000000  B:      1.000000
Alpha:   90.000000  Beta:   90.000000
H:       1.000000  Area:   1.000000
P:       1.414214  Q:     1.414214
```

```
pdata[4] - BadValue = 0
A:       3.000000  B:      4.000000
Alpha:   90.000000  Beta:   90.000000
H:       3.000000  Area:   12.000000
P:       5.000000  Q:     5.000000
```

```
pdata[5] - BadValue = 0
A:       2.000000  B:      3.000000
Alpha:   30.000000  Beta:  150.000000
H:       1.000000  Area:   3.000000
P:       1.614836  Q:     4.836559
```

```
pdata[6] - BadValue = 0
A:       3.000000  B:      2.000000
Alpha:   60.000000  Beta:  120.000000
H:       2.598076  Area:   5.196152
P:       2.645751  Q:     4.358899
```

```
pdata[7] - BadValue = 0
A:      4.000000  B:      2.500000
Alpha:  120.000000 Beta:   60.000000
H:      3.464102  Area:   8.660254
P:      5.678908  Q:      3.500000
```

```
pdata[8] - BadValue = 0
A:      5.000000  B:      7.125000
Alpha:  135.000000 Beta:   45.000000
H:      3.535534  Area:  25.190679
P:     11.231517  Q:      5.038280
```

```
pdata[9] - BadValue = 0
A:      8.000000  B:      8.000000
Alpha:  165.000000 Beta:  15.000000
H:      2.070552  Area:  16.564419
P:     15.863118  Q:      2.088419
```

Summary

In this chapter, you learned how to perform essential scalar floating-point arithmetic using the x86-SSE instruction set. You also examined a couple of sample programs that illustrated advanced x86-SSE scalar floating-point techniques. In the next chapter, you'll continue your x86-SSE assembly language programming education, which focuses on the packed floating-point capabilities of x86-SSE.



X86-SSE Programming – Packed Floating-Point

In this chapter, you learn how to create assembly language functions that manipulate the packed floating-point resources of x86-SSE. You begin by examining a few sample programs that demonstrate essential x86-SSE packed floating-point operations, including basic arithmetic, compares, and data type conversions. This is followed by a section that illustrates use of the x86-SSE instruction set to carry out more sophisticated mathematical techniques using packed single-precision and double-precision floating-point values.

The sample code in this chapter exercises various levels of x86-SSE. The specific level that's required for each assembly language function is shown in its documentation header. As a reminder, you can use one of the freely available utilities listed in Appendix C to determine the version of x86-SSE that's supported by your PC's processor and operating system.

Packed Floating-Point Fundamentals

The sample code in this section explains how to perform fundamental packed floating-point operations, including basic arithmetic, compares, and type conversions. Some of the ensuing sample programs in this chapter use a C++ union named `XmmVal` (see Listing 9-1) to facilitate data exchange between a C++ and assembly language function. The items that are declared in this union match the packed data types supported by x86-SSE. The union `XmmVal` also includes several declarations for text string formatting functions. The file `XmmVal.cpp` (source code not shown) contains definitions for the `ToString_` formatting functions and is included in the sample code distribution file subfolder `CommonFiles`.

Listing 9-1. `XmmVal.h`

```
#pragma once

#include "MiscDefs.h"

union XmmVal
{
    Int8 i8[16];
    Int16 i16[8];
};
```



```

    Int32 i32[4];
    Int64 i64[2];
    UInt8 u8[16];
    UInt16 u16[8];
    UInt32 u32[4];
    UInt64 u64[2];
    float r32[4];
    double r64[2];

    char* ToString_i8(char* s, size_t len);
    char* ToString_i16(char* s, size_t len);
    char* ToString_i32(char* s, size_t len);
    char* ToString_i64(char* s, size_t len);

    char* ToString_u8(char* s, size_t len);
    char* ToString_u16(char* s, size_t len);
    char* ToString_u32(char* s, size_t len);
    char* ToString_u64(char* s, size_t len);

    char* ToString_x8(char* s, size_t len);
    char* ToString_x16(char* s, size_t len);
    char* ToString_x32(char* s, size_t len);
    char* ToString_x64(char* s, size_t len);

    char* ToString_r32(char* s, size_t len);
    char* ToString_r64(char* s, size_t len);
};

```

Packed Floating-Point Arithmetic

The first x86-SSE packed floating-point program that you look at is called `SsePackedFloatingPointArithmetic`. This program illustrates how to perform basic arithmetic operations using packed floating-point operands. The C++ and x86 assembly language source code for this project are shown in Listings 9-2 and 9-3, respectively.

Listing 9-2. `SsePackedFloatingPointArithmetic.cpp`

```

#include "stdafx.h"
#include "XmmVal.h"
#define _USE_MATH_DEFINES
#include <math.h>

extern "C" void SsePackedFpMath32_(const XmmVal* a, const XmmVal* b, XmmVal c[8]);
extern "C" void SsePackedFpMath64_(const XmmVal* a, const XmmVal* b, XmmVal c[8]);

```

```

void SsePackedFpMath32(void)
{
    _declspec(align(16)) XmmVal a;
    _declspec(align(16)) XmmVal b;
    _declspec(align(16)) XmmVal c[8];
    char buff[256];

    a.r32[0] = 36.0f;
    a.r32[1] = (float)(1.0 / 32.0);
    a.r32[2] = 2.0f;
    a.r32[3] = 42.0f;

    b.r32[0] = -(float)(1.0 / 9.0);
    b.r32[1] = 64.0f;
    b.r32[2] = -0.0625f;
    b.r32[3] = 8.666667f;

    SsePackedFpMath32_(&a, &b, c);
    printf("\nResults for SsePackedFpMath32\n");
    printf("a:      %s\n", a.ToString_r32(buff, sizeof(buff)));
    printf("b:      %s\n", b.ToString_r32(buff, sizeof(buff)));
    printf("\n");
    printf("addps:   %s\n", c[0].ToString_r32(buff, sizeof(buff)));
    printf("subps:   %s\n", c[1].ToString_r32(buff, sizeof(buff)));
    printf("mulps:   %s\n", c[2].ToString_r32(buff, sizeof(buff)));
    printf("divps:   %s\n", c[3].ToString_r32(buff, sizeof(buff)));
    printf("absp:    %s\n", c[4].ToString_r32(buff, sizeof(buff)));
    printf("sqrtps:  %s\n", c[5].ToString_r32(buff, sizeof(buff)));
    printf("minps:   %s\n", c[6].ToString_r32(buff, sizeof(buff)));
    printf("maxps:   %s\n", c[7].ToString_r32(buff, sizeof(buff)));
}

void SsePackedFpMath64(void)
{
    _declspec(align(16)) XmmVal a;
    _declspec(align(16)) XmmVal b;
    _declspec(align(16)) XmmVal c[8];
    char buff[256];

    a.r64[0] = 2.0;
    a.r64[1] = M_PI;
    b.r64[0] = M_E;
    b.r64[1] = -M_1_PI;

    SsePackedFpMath64_(&a, &b, c);
    printf("\nResults for SsePackedFpMath64\n");
    printf("a: %s\n", a.ToString_r64(buff, sizeof(buff)));
    printf("b: %s\n", b.ToString_r64(buff, sizeof(buff)));
}

```

```

printf("\n");
printf("addpd:   %s\n", c[0].ToString_r64(buff, sizeof(buff)));
printf("subpd:   %s\n", c[1].ToString_r64(buff, sizeof(buff)));
printf("mulpd:   %s\n", c[2].ToString_r64(buff, sizeof(buff)));
printf("divpd:   %s\n", c[3].ToString_r64(buff, sizeof(buff)));
printf("abspd a: %s\n", c[4].ToString_r64(buff, sizeof(buff)));
printf("sqrtpd a: %s\n", c[5].ToString_r64(buff, sizeof(buff)));
printf("minpd:   %s\n", c[6].ToString_r64(buff, sizeof(buff)));
printf("maxpd:   %s\n", c[7].ToString_r64(buff, sizeof(buff)));
}

int _tmain(int argc, _TCHAR* argv[])
{
    SsePackedFpMath32();
    SsePackedFpMath64();
}

```

Listing 9-3. SsePackedFloatingPointArithmetic.asm

```

.model flat,c
.const

; Mask values used to calculate floating-point absolute values
align 16
Pfp32Abs    dword 7fffffffh,7fffffffh,7fffffffh,7fffffffh
Pfp64Abs    qword 7fffffffffffffffh,7fffffffffffffffh
.code

; extern "C" void SsePackedFpMath32_(const XmmVal* a, const XmmVal* b,
XmmVal c[8]);
;
; Description: The following function demonstrates basic math using
;              packed single-precision floating-point values.
;
; Requires:    SSE

SsePackedFpMath32_ proc
    push ebp
    mov ebp,esp

; Load packed SP floating-point values
    mov eax,[ebp+8]           ;eax = 'a'
    mov ecx,[ebp+12]         ;ecx = 'b'
    mov edx,[ebp+16]         ;edx = 'c'
    movaps xmm0,[eax]        ;xmm0 = *a
    movaps xmm1,[ecx]        ;xmm1 = *b

```

```

; Packed SP floating-point addition
    movaps xmm2,xmm0
    addps xmm2,xmm1
    movaps [edx+0],xmm2

; Packed SP floating-point subtraction
    movaps xmm2,xmm0
    subps xmm2,xmm1
    movaps [edx+16],xmm2

; Packed SP floating-point multiplication
    movaps xmm2,xmm0
    mulps xmm2,xmm1
    movaps [edx+32],xmm2

; Packed SP floating-point division
    movaps xmm2,xmm0
    divps xmm2,xmm1
    movaps [edx+48],xmm2

; Packed SP floating-point absolute value
    movaps xmm2,xmm0
    andps xmm2,xmmword ptr [Pfp32Abs]
    movaps [edx+64],xmm2

; Packed SP floating-point square root
    sqrtps xmm2,xmm0
    movaps [edx+80],xmm2

; Packed SP floating-point minimum
    movaps xmm2,xmm0
    minps xmm2,xmm1
    movaps [edx+96],xmm2

; Packed SP floating-point maximum
    maxps xmm0,xmm1
    movaps [edx+112],xmm0

    pop ebp
    ret
SsePackedFpMath32_ endp

; extern "C" void SsePackedFpMath64_(const XmmVal* a, const XmmVal* b,
XmmVal c[8]);
;
; Description: The following function demonstrates basic math using
;             packed double-precision floating-point values.
;
; Requires:   SSE2

```

```

SsePackedFpMath64_ proc
    push ebp
    mov ebp,esp

; Load packed DP floating-point values
    mov eax,[ebp+8]           ;eax = 'a'
    mov ecx,[ebp+12]        ;ecx = 'b'
    mov edx,[ebp+16]        ;edx = 'c'
    movapd xmm0,[eax]       ;xmm0 = *a
    movapd xmm1,[ecx]       ;xmm1 = *b

; Packed DP floating-point addition
    movapd xmm2,xmm0
    addpd xmm2,xmm1
    movapd [edx+0],xmm2

; Packed DP floating-point subtraction
    movapd xmm2,xmm0
    subpd xmm2,xmm1
    movapd [edx+16],xmm2

; Packed DP floating-point multiplication
    movapd xmm2,xmm0
    mulpd xmm2,xmm1
    movapd [edx+32],xmm2

; Packed DP floating-point division
    movapd xmm2,xmm0
    divpd xmm2,xmm1
    movapd [edx+48],xmm2

; Packed DP floating-point absolute value
    movapd xmm2,xmm0
    andpd xmm0,xmmword ptr [Pfp64Abs]
    movapd [edx+64],xmm2

; Packed DP floating-point square root
    sqrtpd xmm2,xmm0
    movapd [edx+80],xmm2

; Packed DP floating-point minimum
    movapd xmm2,xmm0
    minpd xmm2,xmm1
    movapd [edx+96],xmm2

```

```

; Packed DP floating-point maximum
    maxpd xmm0,xmm1
    movapd [edx+112],xmm0

    pop ebp
    ret
SsePackedFpMath64_ endp
end

```

The C++ file `SsePackedFloatingPointArithmetic.cpp` (see Listing 9-2) contains a function named `SsePackedFpMath32` that defines and initializes a couple of `XmmVal` instances using packed single-precision floating-point values. Note that the `XmmVal` variables are declared using the Visual C++ extended attribute `__declspec(align(16))`, which aligns each instance to a 16-byte boundary. The assembly language function `SsePackedFpMath32_` performs the required packed arithmetic and returns its results to the specified array. The result of each packed arithmetic operation is then displayed. The functions `SsePackedFpMath64` and `SsePackedFpMath64_` perform a similar set of operations for packed double-precision floating-point values.

The functions `SsePackedFpMath32_` and `SsePackedFpMath64_` are defined in `SsePackedFloatingPointArithmetic_.asm` (see Listing 9-3). These functions illustrate use of common x86-SSE packed single-precision and double-precision floating-point instructions. Note that the `movaps` and `movapd` (Move Aligned Packed Single-Precision/Double-Precision Floating-Point Values) instructions require 16-byte alignment of a source or destination operand in memory. The rounding mode that's specified in `MXCSR.RC` also applies to packed floating-point arithmetic. Output 9-1 shows the results of `SsePackedFloatingPointArithmetic`.

Output 9-1. Sample Program `SsePackedFloatingPointArithmetic`

Results for `SsePackedFpMath32_`

a:	36.000000	0.031250		2.000000	42.000000
b:	-0.111111	64.000000		-0.062500	8.666667
addps:	35.888889	64.031250		1.937500	50.666668
subps:	36.111111	-63.968750		2.062500	33.333332
mulps:	-4.000000	2.000000		-0.125000	364.000000
divps:	-324.000000	0.000488		-32.000000	4.846154
absp a:	36.000000	0.031250		2.000000	42.000000
sqrtps a:	6.000000	0.176777		1.414214	6.480741
minps:	-0.111111	0.031250		-0.062500	8.666667
maxps:	36.000000	64.000000		2.000000	42.000000

Results for `SsePackedFpMath64_`

a:	2.000000000000		3.141592653590
b:	2.718281828459		-0.318309886184

addpd:	4.718281828459		2.823282767406
subpd:	-0.718281828459		3.459902539774
mulpd:	5.436563656918		-1.000000000000
divpd:	0.735758882343		-9.869604401089
absdpd a:	2.000000000000		3.141592653590
sqrtpd a:	1.414213562373		1.772453850906
minpd:	2.000000000000		-0.318309886184
maxpd:	2.718281828459		3.141592653590

Packed Floating-Point Compare

In Chapter 8, you learned how to compare scalar single-precision and double-precision floating-point values using the `comiss` and `comisd` instructions, respectively. X86-SSE also includes instructions that perform packed floating-point compares. The `cmpps` and `cmpsd` (Compare Packed Single-Precision and Double-Precision Floating-Point Values) instructions perform SIMD compare operations using two packed values. Unlike their scalar counterparts, the packed compare instructions require a third operand that specifies a compare predicate. They also report their results by loading doubleword mask values into an XMM register instead of setting status bits in the EFLAGS register.

The required syntax of a `cmp X` ($X = s$ or d) instruction is `cmp X CmpOp1, CmpOp2, PredOp`, where `CmpOp1` is the first source operand and must be an XMM register; `CmpOp2` is the second source operand and can be an XMM register or 128-bit wide packed operand in memory; and `PredOp` is an immediate value that specifies the compare predicate. Table 9-1 summarizes the eight compare predicates supported by x86-SSE. The results of a packed compare are saved to `CmpOp1` as a doubleword mask, where all 1s represent a true compare and all 0s signify false. As an alternative to using an immediate compare predicate, many assemblers including MASM support packed compare pseudo-instructions, which enhance code readability. These pseudo-instructions are included in Table 9-1.

Table 9-1. Compare Predicate Information for `cmpps` and `cmpsd` Instructions

PredOp	Predicate	Description	Pseudo-Instructions
0	EQ	<code>CmpOp1 == CmpOp2</code>	<code>cmpeqp(s d)</code>
1	LT	<code>CmpOp1 < CmpOp2</code>	<code>cmpltp(s d)</code>
2	LE	<code>CmpOp1 <= CmpOp2</code>	<code>cmplep(s d)</code>
3	UNORD	<code>CmpOp1 && CmpOp2</code> are unordered	<code>cmpunordp(s d)</code>
4	NEQ	<code>!(CmpOp1 == CmpOp2)</code>	<code>cmpneqp(s d)</code>
5	NLT	<code>!(CmpOp1 < CmpOp2)</code>	<code>cmpnltp(s d)</code>
6	NLE	<code>!(CmpOp1 <= CmpOp2)</code>	<code>cmpnlep(s d)</code>
7	ORD	<code>CmpOp1 && CmpOp2</code> are ordered	<code>cmpordp(s d)</code>

Note that in Table 9-1 the NLT predicate is equivalent to greater than or equal (GE) and NLE is equivalent to greater than (GT).

Figure 9-1 depicts the execution of a `cmpps xmm0,xmm1,0` (or `cmpeqps xmm0,xmm1`) instruction. In this example, the single-precision floating-point values in XMM0 and XMM1 are compared for equality. If the values are equal, a mask of `0xFFFFFFFF` is written to the corresponding position in XMM0; otherwise, `0x00000000` is written.

cmpps xmm0,xmm1,0 (or cmpeqps xmm0, xmm1)				
4.125	2.375	-72.5	44.125	xmm1
8.625	2.375	-72.5	15.875	xmm0
0x00000000	0xFFFFFFFF	0xFFFFFFFF	0x00000000	xmm0

Figure 9-1. Execution of a `cmpps` instruction

`SsePackedFloatingPointCompare` is the name of the sample program in this section. This program elucidates execution of the `cmpps` instruction using packed single-precision floating-point values (operation of `cmppd` is the same except that it uses packed double-precision floating-point values). The C++ and assembly language source code is shown in Listings 9-4 and 9-5, respectively.

Listing 9-4. `SsePackedFloatingPointCompare.cpp`

```
#include "stdafx.h"
#include "XmmVal.h"
#include <limits>
using namespace std;

extern "C" void SsePfpCompareFloat_(const XmmVal* a, const XmmVal* b, XmmVal c[8]);

const char* CmpStr[8] =
{
    "EQ", "LT", "LE", "UNORDERED", "NE", "NLT", "NLE", "ORDERED"
};

void SsePfpCompareFloat(void)
{
    __declspec(align(16)) XmmVal a;
    __declspec(align(16)) XmmVal b;
    __declspec(align(16)) XmmVal c[8];
    char buff[256];

    a.r32[0] = 2.0;      b.r32[0] = 1.0;
    a.r32[1] = 7.0;      b.r32[1] = 12.0;
    a.r32[2] = -6.0;     b.r32[2] = -6.0;
    a.r32[3] = 3.0;      b.r32[3] = 8.0;
```



```

for (int i = 0; i < 2; i++)
{
    if (i == 1)
        a.r32[0] = numeric_limits<float>::quiet_NaN();

    SsePfpCompareFloat_(&a, &b, c);

    printf("\nResults for SsePfpCompareFloat_ (Iteration %d)\n", i);
    printf("a: %s\n", a.ToString_r32(buff, sizeof(buff)));
    printf("b: %s\n", b.ToString_r32(buff, sizeof(buff)));
    printf("\n");

    for (int j = 0; j < 8; j++)
    {
        char* s = c[j].ToString_x32(buff, sizeof(buff));
        printf("%10s: %s\n", CmpStr[j], s);
    }
}

int _tmain(int argc, _TCHAR* argv[])
{
    SsePfpCompareFloat();
    return 0;
}

```

Listing 9-5. SsePackedFloatingPointCompare_.asm

```

.model flat,c
.code

; extern "C" void SsePfpCompareFloat_(const XmmVal* a, const XmmVal* b, ←
XmmVal c[8]);
;
; Description: The following program illustrates use of the cmpps
;               instruction.
;
; Requires:     SSE2

SsePfpCompareFloat_ proc
    push ebp
    mov ebp,esp

    mov eax,[ebp+8]           ;eax = ptr to 'a'
    mov ecx,[ebp+12]         ;ecx = ptr to 'b'
    mov edx,[ebp+16]         ;edx = ptr to 'c'
    movaps xmm0,[eax]        ;load 'a' into xmm0
    movaps xmm1,[ecx]        ;load 'b' into xmm1

```

```

; Perform packed EQUAL compare
    movaps xmm2,xmm0
    cmpeqps xmm2,xmm1
    movdqa [edx],xmm2

; Perform packed LESS THAN compare
    movaps xmm2,xmm0
    cmpltps xmm2,xmm1
    movdqa [edx+16],xmm2

; Perform packed LESS THAN OR EQUAL compare
    movaps xmm2,xmm0
    cmpleps xmm2,xmm1
    movdqa [edx+32],xmm2

; Perform packed UNORDERED compare
    movaps xmm2,xmm0
    cmpunordps xmm2,xmm1
    movdqa [edx+48],xmm2

; Perform packed NOT EQUAL compare
    movaps xmm2,xmm0
    cmpneqps xmm2,xmm1
    movdqa [edx+64],xmm2

; Perform packed NOT LESS THAN compare
    movaps xmm2,xmm0
    cmpnltps xmm2,xmm1
    movdqa [edx+80],xmm2

; Perform packed NOT LESS THAN OR EQUAL compare
    movaps xmm2,xmm0
    cmpnleps xmm2,xmm1
    movdqa [edx+96],xmm2

; Perform packed ORDERED compare
    movaps xmm2,xmm0
    cmpordps xmm2,xmm1
    movdqa [edx+112],xmm2

    pop ebp
    ret
SsePfpCompareFloat_ endp
end

```

The C++ source code (see Listing 9-4) contains a simple function that initializes a couple of packed floating-point variables, invokes the assembly language compare function, and prints the results. Note that on the second iteration of the `for` loop, a NaN value is copied into `XmmVal` variable `a` in order to verify correct operation of the ordered and unordered predicates. The assembly language function `SsePfpCompareFloat_` (see Listing 9-5) loads registers `XMM0` and `XMM1` with the packed values `a` and `b`. It then executes all eight predicate compares and saves the results of each operation to the specified array. The assembly language function uses the compare pseudo-instructions in order to improve readability. Another reason for becoming familiar with the pseudo-instructions is that the x86-AVX version of `cmpss` supports 32 compare predicates, which are significantly more challenging to remember than the eight supported by x86-SSE. Output 9-2 shows the results of the `SsePackedFloatingPointCompare` sample program.

Output 9-2. Sample Program `SsePackedFloatingPointCompare`

```
Results for SsePfpCompareFloat_ (Iteration 0)
a:   2.000000   7.000000 |  -6.000000   3.000000
b:   1.000000  12.000000 |  -6.000000   8.000000

      EQ: 00000000 00000000 | FFFFFFFF 00000000
      LT: 00000000 FFFFFFFF | 00000000 FFFFFFFF
      LE: 00000000 FFFFFFFF | FFFFFFFF FFFFFFFF
UNORDERED: 00000000 00000000 | 00000000 00000000
      NE: FFFFFFFF FFFFFFFF | 00000000 FFFFFFFF
      NLT: FFFFFFFF 00000000 | FFFFFFFF 00000000
      NLE: FFFFFFFF 00000000 | 00000000 00000000
ORDERED: FFFFFFFF FFFFFFFF | FFFFFFFF FFFFFFFF

Results for SsePfpCompareFloat_ (Iteration 1)
a:   1.#QNANO   7.000000 |  -6.000000   3.000000
b:   1.000000  12.000000 |  -6.000000   8.000000

      EQ: 00000000 00000000 | FFFFFFFF 00000000
      LT: 00000000 FFFFFFFF | 00000000 FFFFFFFF
      LE: 00000000 FFFFFFFF | FFFFFFFF FFFFFFFF
UNORDERED: FFFFFFFF 00000000 | 00000000 00000000
      NE: FFFFFFFF FFFFFFFF | 00000000 FFFFFFFF
      NLT: FFFFFFFF 00000000 | FFFFFFFF 00000000
      NLE: FFFFFFFF 00000000 | 00000000 00000000
ORDERED: 00000000 FFFFFFFF | FFFFFFFF FFFFFFFF
```

Packed Floating-Point Conversions

The next x86-SSE packed floating-point program that you examine is called `SsePackedFloatingPointConversions`. This program demonstrates how to convert a packed doubleword signed integer value to a packed single-precision or packed double-precision floating-point value and vice versa. It also shows conversions between

packed single-precision and double-precision floating-point values. Listings 9-6 and 9-7 show the C++ and assembly language source code for the sample program `SsePackedFloatingPointConversions`.

Listing 9-6. `SsePackedFloatingPointConversions.cpp`

```
#include "stdafx.h"
#include "XmmVal.h"
#define _USE_MATH_DEFINES
#include <math.h>

// The order of values in the following enum must match the table
// that's defined in SsePackedFloatingPointConversions_.asm.
enum CvtOp : unsigned int
{
    Cvtdq2ps,           // Packed signed doubleword to SPFP
    Cvtdq2pd,          // Packed signed doubleword to DPFP
    Cvtps2dq,           // Packed SPFP to signed doubleword
    Cvtpd2dq,          // Packed DPFP to signed doubleword
    Cvtps2pd,           // Packed SPFP to DPFP
    Cvtpd2ps           // Packed DPFP to SPFP
};

extern "C" void SsePfpConvert_(const XmmVal* a, XmmVal* b, CvtOp cvt_op);

void SsePfpConversions32(void)
{
    _declspec(align(16)) XmmVal a;
    _declspec(align(16)) XmmVal b;
    char buff[256];

    a.i32[0] = 10;
    a.i32[1] = -500;
    a.i32[2] = 600;
    a.i32[3] = -1024;
    SsePfpConvert_(&a, &b, CvtOp::Cvtdq2ps);
    printf("\nResults for CvtOp::Cvtdq2ps\n");
    printf(" a: %s\n", a.ToString_i32(buff, sizeof(buff)));
    printf(" b: %s\n", b.ToString_r32(buff, sizeof(buff)));

    a.r32[0] = 1.0f / 3.0f;
    a.r32[1] = 2.0f / 3.0f;
    a.r32[2] = -a.r32[0] * 2.0f;
    a.r32[3] = -a.r32[1] * 2.0f;
    SsePfpConvert_(&a, &b, CvtOp::Cvtps2dq);
    printf("\nResults for CvtOp::Cvtps2dq\n");
    printf(" a: %s\n", a.ToString_r32(buff, sizeof(buff)));
    printf(" b: %s\n", b.ToString_i32(buff, sizeof(buff)));
}
```

```

    // cvtps2pd converts the two low-order SPFP values of 'a'
    a.r32[0] = 1.0f / 7.0f;
    a.r32[1] = 2.0f / 9.0f;
    a.r32[2] = 0;
    a.r32[3] = 0;
    SsePfpConvert_(&a, &b, CvtOp::Cvtps2pd);
    printf("\nResults for CvtOp::Cvtps2pd\n");
    printf(" a: %s\n", a.ToString_r32(buff, sizeof(buff)));
    printf(" b: %s\n", b.ToString_r64(buff, sizeof(buff)));
}

void SsePfpConversions64(void)
{
    _declspec(align(16)) XmmVal a;
    _declspec(align(16)) XmmVal b;
    char buff[256];

    // cvtdq2pd converts the two low-order doubleword integers of 'a'
    a.i32[0] = 10;
    a.i32[1] = -20;
    a.i32[2] = 0;
    a.i32[3] = 0;
    SsePfpConvert_(&a, &b, CvtOp::Cvtdq2pd);
    printf("\nResults for CvtOp::Cvtdq2pd\n");
    printf(" a: %s\n", a.ToString_i32(buff, sizeof(buff)));
    printf(" b: %s\n", b.ToString_r64(buff, sizeof(buff)));

    // cvtpd2dq sets the two high-order doublewords of 'b' to zero
    a.r64[0] = M_PI;
    a.r64[1] = M_E;
    SsePfpConvert_(&a, &b, CvtOp::Cvtpd2dq);
    printf("\nResults for CvtOp::Cvtpd2dq\n");
    printf(" a: %s\n", a.ToString_r64(buff, sizeof(buff)));
    printf(" b: %s\n", b.ToString_i32(buff, sizeof(buff)));

    // cvtpd2ps sets the two high-order SPFP values of 'b' to zero
    a.r64[0] = M_SQRT2;
    a.r64[1] = M_SQRT1_2;
    SsePfpConvert_(&a, &b, CvtOp::Cvtpd2ps);
    printf("\nResults for CvtOp::Cvtpd2ps\n");
    printf(" a: %s\n", a.ToString_r64(buff, sizeof(buff)));
    printf(" b: %s\n", b.ToString_r32(buff, sizeof(buff)));
}

```

```
int _tmain(int argc, _TCHAR* argv[])
{
    SsePfpConversions32();
    SsePfpConversions64();
    return 0;
}
```

Listing 9-7. SsePackedFloatingPointConversions_.asm

```
.model flat,c
.code

; extern "C" void SsePfpConvert_(const XmmVal* a, XmmVal* b, CvtOp cvt_op);
;
; Description: The following function demonstrates use of the packed
;               floating-point conversion instructions.
;
; Requires:     SSE2

SsePfpConvert_ proc
    push ebp
    mov ebp,esp

; Load arguments and make sure 'cvt_op' is valid
    mov eax,[ebp+8]                ;eax = 'a'
    mov ecx,[ebp+12]              ;ecx = 'b'
    mov edx,[ebp+16]              ;edx =cvt_op
    cmp edx,CvtOpTableCount
    jae BadCvtOp
    jmp [CvtOpTable+edx*4]        ;jump to specified conversion

; Convert packed doubleword signed integers to packed SPFP values
SseCvtdq2ps:
    movdqa xmm0,[eax]
    cvtdq2ps xmm1,xmm0
    movaps [ecx],xmm1
    pop ebp
    ret

; Convert packed doubleword signed integers to packed DPFP values
SseCvtdq2pd:
    movdqa xmm0,[eax]
    cvtdq2pd xmm1,xmm0
    movapd [ecx],xmm1
    pop ebp
    ret
```

```
; Convert packed SPFP values to packed doubleword signed integers
SseCvtps2dq:
```

```
    movaps xmm0,[eax]
    cvtps2dq xmm1,xmm0
    movdqa [ecx],xmm1
    pop ebp
    ret
```

```
; Convert packed DFPF values to packed doubleword signed integers
SseCvtpd2dq:
```

```
    movapd xmm0,[eax]
    cvtpd2dq xmm1,xmm0
    movdqa [ecx],xmm1
    pop ebp
    ret
```

```
; Convert packed SPFP to packed DFPF
```

```
SseCvtps2pd:
```

```
    movaps xmm0,[eax]
    cvtps2pd xmm1,xmm0
    movapd [ecx],xmm1
    pop ebp
    ret
```

```
; Convert packed DFPF to packed SPFP
```

```
SseCvtpd2ps:
```

```
    movapd xmm0,[eax]
    cvtpd2ps xmm1,xmm0
    movaps [ecx],xmm1
    pop ebp
    ret
```

```
BadCvtOp:
```

```
    pop ebp
    ret
```

```
; The order of values in the following table must match the enum CvtOp
; that's defined in SsePackedFloatingPointConversions.cpp.
```

```
    align 4
CvtOpTable  dword SseCvtdq2ps, SseCvtdq2pd, SseCvtps2dq
            dword SseCvtpd2dq, SseCvtps2pd, SseCvtpd2ps
CvtOpTableCount equ ($ - CvtOpTable) / size dword
SsePfpConvert_ endp
    end
```

The C++ file `SsePackedFloatingPointConversions.cpp` (see Listing 9-6) contains an enum named `CvtOp` that lists the valid conversion operators. Note that a few of the enumeration names and corresponding x86 assembly language mnemonics are somewhat confusing. The letters `dq` are used to designate a packed doubleword signed integer and not a double quadword as might be expected. Also note that the actual number of items converted depends on the data types. For example, the enumeration `CvtOp::Cvtps2pd` (or `cvtps2pd` instruction) converts the two low-order single-precision floating-point values to two double-precision floating-point values. When converting packed double-precision floating-point values to single-precision or doubleword signed integers, the high-order values in the destination operand are set to zero.

The assembly language file `SsePackedFloatingPointConversions_asm` (see Listing 9-7) employs a jump table to execute the chosen conversion instruction. For each conversion code block, packed data transfers to and from memory are carried out using a `movaps`, `movapd`, or `movdqa` (Move Aligned Double Quadword) instruction. All of these instructions require proper alignment of any memory-based operand. The packed conversion instructions use the rounding mode that's specified by `MXCSR.RC`. The default rounding mode for Visual C++ is round to nearest. Some of the packed conversion instructions also set the invalid operation flag (`MXCSR.IE`) if invalid operation exceptions (`MXCSR.IM`) are masked and the specific conversion cannot be performed. The results of the `SsePackedFloatingPointConversions` sample program are shown in Output 9-3.

Output 9-3. Sample Program `SsePackedFloatingPointConversions`

Results for `CvtOp::Cvtdq2ps`

a:	10	-500		600	-1024
b:	10.000000	-500.000000		600.000000	-1024.000000

Results for `CvtOp::Cvtps2dq`

a:	0.333333	0.666667		-0.666667	-1.333333
b:	0	1		-1	-1

Results for `CvtOp::Cvtps2pd`

a:	0.142857	0.222222		0.000000	0.000000
b:	0.142857149243			0.222222223878	

Results for `CvtOp::Cvtdq2pd`

a:	10	-20		0	0
b:	10.000000000000			-20.000000000000	

Results for `CvtOp::Cvtpd2dq`

a:	3.141592653590			2.718281828459	
b:	3	3		0	0

Results for `CvtOp::Cvtpd2ps`

a:	1.414213562373			0.707106781187	
b:	1.414214	0.707107		0.000000	0.000000

Advanced Packed Floating-Point Programming

The sample code in this section illustrates the use of the x86-SSE instruction set to implement common mathematical techniques using packed single-precision and double-precision floating-point values. In the first sample program, you learn how to perform SIMD arithmetic using double-precision floating-point arrays. The second sample program explains how to use the computational resources of x86-SSE to improve the performance of algorithms that exercise 4×4 matrices.

Packed Floating-Point Least Squares

In Chapter 4 you studied a sample program that calculated the slope and intercept of a least squares regression line using the x87 FPU. The sample program of this section calculates a regression line slope and intercept using x86-SSE packed double-precision floating-point arithmetic. Listings 9-8 and 9-9 show the source for the sample program `SsePackedFloatingPointLeastSquares`.

Listing 9-8. `SsePackedFloatingPointLeastSquares.cpp`

```
#include "stdafx.h"
#include <stddef.h>
#include <math.h>

extern "C" double LsEpsilon = 1.0e-12;
extern "C" bool SsePfpLeastSquares_(const double* x, const double* y,
int n, double* m, double* b);

bool SsePfpLeastSquaresCpp(const double* x, const double* y, int n,
double* m, double* b)
{
    if (n < 2)
        return false;

    // Make sure x and y are properly aligned
    if (((uintptr_t)x & 0xf) != 0 || ((uintptr_t)y & 0xf) != 0)
        return false;

    double sum_x = 0, sum_y = 0.0, sum_xx = 0, sum_xy = 0.0;

    for (int i = 0; i < n; i++)
    {
        sum_x += x[i];
        sum_xx += x[i] * x[i];
        sum_xy += x[i] * y[i];
        sum_y += y[i];
    }
}
```

```

double denom = n * sum_xx - sum_x * sum_x;

if (fabs(denom) >= LsEpsilon)
{
    *m = (n * sum_xy - sum_x * sum_y) / denom;
    *b = (sum_xx * sum_y - sum_x * sum_xy) / denom;
    return true;
}
else
{
    *m = *b = 0.0;
    return false;
}
}

int _tmain(int argc, _TCHAR* argv[])
{
    const int n = 11;
    __declspec(align(16)) double x[n] = {10, 13, 17, 19, 23, 7, 35, 51, 89, 92, 99};
    __declspec(align(16)) double y[n] = {1.2, 1.1, 1.8, 2.2, 1.9, 0.5, 3.1, 5.5, 8.4, 9.7, 10.4};

    double m1, m2, b1, b2;
    bool rc1 = SsePfpLeastSquaresCpp(x, y, n, &m1, &b1);
    bool rc2 = SsePfpLeastSquares_(x, y, n, &m2, &b2);

    printf("\nResults from SsePackedFloatingPointLeastSquaresCpp\n");
    printf(" rc:      %12d\n", rc1);
    printf(" slope:   %12.8lf\n", m1);
    printf(" intercept: %12.8lf\n", b1);
    printf("\nResults from SsePackedFloatingPointLeastSquares_\n");
    printf(" rc:      %12d\n", rc2);
    printf(" slope:   %12.8lf\n", m2);
    printf(" intercept: %12.8lf\n", b2);
    return 0;
}

```

Listing 9-9. SsePackedFloatingPointLeastSquares_.asm

```

.model flat,c
extern LsEpsilon:real8
.const
PackedFp64Abs qword 7fffffffffffffffh,7fffffffffffffffh
.code

```

```

; extern "C" bool SsePfpLeastSquares_(const double* x, const double* y,
int n, double* m, double* b);
;
; Description: The following function computes the slope and intercept
;              of a least squares regression line.
;
; Returns      0 = error (invalid n or improperly aligned array)
;              1 = success
;
; Requires:    SSE3

```

```
SsePfpLeastSquares_ proc
```

```

    push ebp
    mov  ebp,esp
    push ebx

```

```
; Load and validate arguments
```

```

    xor  eax,eax                ;set error return code
    mov  ebx,[ebp+8]           ;ebx = 'x'
    test ebx,0fh
    jnz  Done                  ;jump if 'x' not aligned
    mov  edx,[ebp+12]         ;edx = 'y'
    test edx,0fh
    jnz  Done                  ;jump if 'y' not aligned
    mov  ecx,[ebp+16]         ;ecx = n
    cmp  ecx,2
    jl   Done                  ;jump if n < 2

```

```
; Initialize sum registers
```

```

    cvtsi2sd xmm3,ecx         ;xmm3 = DFPF n
    mov  eax,ecx
    and  ecx,0fffffffh       ;ecx = n / 2 * 2
    and  eax,1                ;eax = n % 2

    xorpd xmm4,xmm4          ;sum_x (both qwords)
    xorpd xmm5,xmm5          ;sum_y (both qwords)
    xorpd xmm6,xmm6          ;sum_xx (both qwords)
    xorpd xmm7,xmm7          ;sum_xy (both qwords)

```

```
; Calculate sum variables. Note that two values are processed each cycle.
```

```

@@:  movapd xmm0,xmmword ptr [ebx] ;load next two x values
     movapd xmm1,xmmword ptr [edx] ;load next two y values
     movapd xmm2,xmm0             ;copy of x

     addpd  xmm4,xmm0             ;update sum_x
     addpd  xmm5,xmm1             ;update sum_y
     mulpd  xmm0,xmm0             ;calc x * x

```

```

    addpd xmm6,xmm0           ;update sum_xx
    mulpd xmm2,xmm1           ;calc x * y
    addpd xmm7,xmm2           ;update sum_xy

    add ebx,16                 ;ebx = next x array value
    add edx,16                 ;edx = next x array value
    sub ecx,2                  ;adjust counter
    jnz @B                     ;repeat until done

; Update sum variables with final x, y values if 'n' is odd
or eax,eax
jz CalcFinalSums             ;jump if n is even
movsd xmm0,real8 ptr [ebx]   ;load final x
movsd xmm1,real8 ptr [edx]   ;load final y
movsd xmm2,xmm0

    addsd xmm4,xmm0           ;update sum_x
    addsd xmm5,xmm1           ;update sum_y
    mulsd xmm0,xmm0           ;calc x * x
    addsd xmm6,xmm0           ;update sum_xx
    mulsd xmm2,xmm1           ;calc x * y
    addsd xmm7,xmm2           ;update sum_xy

; Calculate final sum values
CalcFinalSums:
    haddpd xmm4,xmm4          ;xmm4[63:0] = final sum_x
    haddpd xmm5,xmm5          ;xmm5[63:0] = final sum_y
    haddpd xmm6,xmm6          ;xmm6[63:0] = final sum_xx
    haddpd xmm7,xmm7          ;xmm7[63:0] = final sum_xy

; Compute denom and make sure it's valid
; denom = n * sum_xx - sum_x * sum_x
    movsd xmm0,xmm3           ;n
    movsd xmm1,xmm4           ;sum_x
    mulsd xmm0,xmm6           ;n * sum_xx
    mulsd xmm1,xmm1           ;sum_x * sum_x
    subsd xmm0,xmm1           ;xmm0 = denom
    movsd xmm2,xmm0
    andpd xmm2,xmmword ptr [PackedFp64Abs] ;xmm2 = fabs(denom)
    comisd xmm2,real8 ptr [LsEpsilon]
    jb BadDenom               ;jump if denom < fabs(denom)

; Compute and save slope
; slope = (n * sum_xy - sum_x * sum_y) / denom
    movsd xmm1,xmm4           ;sum_x
    mulsd xmm3,xmm7           ;n * sum_xy
    mulsd xmm1,xmm5           ;sum_x * sum_y

```

```

        subsd xmm3,xmm1                ;slope_numerator
        divsd xmm3,xmm0                ;xmm3 = final slope
        mov  edx,[ebp+20]              ;edx = 'm'
        movsd real8 ptr [edx],xmm3    ;save slope

; Compute and save intercept
; intercept = (sum_xx * sum_y - sum_x * sum_xy) / denom
        mulsd xmm6,xmm5                ;sum_xx * sum_y
        mulsd xmm4,xmm7                ;sum_x * sum_xy
        subsd xmm6,xmm4                ;intercept_numerator
        divsd xmm6,xmm0                ;xmm6 = final intercept
        mov  edx,[ebp+24]              ;edx = 'b'
        movsd real8 ptr [edx],xmm6    ;save intercept
        mov  eax,1                     ;success return code

Done:   pop  ebx
        pop  ebp
        ret

; Set 'm' and 'b' to 0.0
BadDenom:
        xor  eax,eax                    ;set error code
        mov  edx,[ebp+20]              ;eax = 'm'
        mov  [edx],eax
        mov  [edx+4],eax                ;*m = 0.0
        mov  edx,[ebp+24]              ;edx = 'b'
        mov  [edx],eax
        mov  [edx+4],eax                ;*b = 0.0
        jmp  Done

SsePfpLeastSquares_ endp
end

```

The source file `SsePackedFloatingPointLeastSquares.cpp` (see Listing 9-8) includes a C++ function named `SsePfpLeastSquaresCpp` that calculates the slope and intercept for comparison purposes. The function `_tmain` defines a couple of test arrays named `x` and `y` using the extended attribute `__declspec(align(16))`, which instructs the compiler to align each of these arrays on a 16-byte boundary. The remainder of `_tmain` calls both implementations of the least squares algorithm and prints the results.

The assembly language code for function `SsePfpLeastSquares_` (see Listing 9-9) begins by validating `n` for size and the arrays `x` and `y` for proper alignment. The test `ebx,0fh` instruction performs a bitwise AND of the address of array `x` and `0x0f`; a non-zero result indicates that the array is improperly aligned. A similar check is also performed for array `y`. Following validation of the function arguments, a series of initializations is performed. A `cvttsi2sd xmm3,ecx` instruction converts the value of `n` to double-precision floating-point for later use. The value in `ECX` is then rounded down to

the nearest even number using an `and ecx,0fffffffh` instruction and `EAX` is set to 0 or 1 depending on whether the original value of `n` is even or odd. These adjustments are required in order to ensure proper processing of arrays `x` and `y` using packed arithmetic.

Recall from the discussions in Chapter 4 that in order to compute the slope and intercept of a least squares regression line, you need to calculate four intermediate sum values: `sum_x`, `sum_y`, `sum_xx`, and `sum_xy`. The summation loop that calculates these values in this sample program uses packed double-precision floating-point arithmetic. This means that the function can process two elements from arrays `x` and `y` during each loop iteration, which halves the number of required iterations. The sum values for array elements with even-numbered indices are computed using the low-order quadwords of `XMM4-XMM7`, while the high-order quadwords are used to calculate the sum values for array elements with odd-numbered indices.

Prior to entering the summation loop, each sum value register is initialized to 0 using an `xorpd` instruction. At the top of the summation loop, a `movapd xmm0,xmmword ptr [ebx]` essentially copies `x[i]` and `x[i+1]` into the low-order and high-order quadwords of `XMM0`, respectively. The next instruction, `movapd xmm1,xmmword ptr [edx]`, loads `y[i]` and `y[i+1]` into the low-order and high-order quadwords of `XMM1`. A sequence of `addpd` and `mulpd` instructions updates the packed sum values that are maintained in `XMM4-XMM7`. Array pointer registers `EBX` and `EDX` are then incremented by 16 (or the size of two double-precision floating-point values) and the count value in `ECX` is adjusted before the next summation loop iteration. Following completion of the summation loop, a check is made to determine if the original value of `n` was odd. If this is true, the last element of array `x` and array `y` must be included in the packed sum values. Note that the scalar instructions `addsd` and `mulsd` are used to carry out this operation.

Following computation of the packed sum values, a series of `haddpd` (Packed Double-FP Horizontal Add) instructions compute the final values of `sum_x`, `sum_y`, `sum_xx`, and `sum_xy`. Each `haddpd DestOp, SrcOp` instruction computes `DestOp[63:0] = DestOp[127:64] + DestOp[63:0]` and `DestOp[127:64] = SrcOp[127:64] + SrcOp[63:0]`. Subsequent to the execution of the `haddpd` instructions, the low-order quadwords of registers `XMM4-XMM7` contain the final sum values. The high-order quadwords of these registers also contain the final sum values, but this is a consequence of using `haddpd` with the same source and destination operand. The value of `denom` is computed next and tested to make sure it's greater than or equal to `LsEpsilon` (values less than `LsEpsilon` are considered too close to zero to be valid). After validation of `denom`, the slope and intercept values are calculated using simple x86-SSE scalar arithmetic. Output 9-4 shows the results of `SsePackedFloatingPointLeastSquares`.

Output 9-4. Sample Program `SsePackedFloatingPointLeastSquares`

Results from `SsePackedFloatingPointLeastSquaresCpp`

```
rc:          1
slope:       0.10324631
intercept:   -0.10700632
```

Results from `SsePackedFloatingPointLeastSquares_`

```
rc:          1
slope:       0.10324631
intercept:   -0.10700632
```

Packed Floating-Point 4×4 Matrices

Software applications such as computer graphics and computer-aided design programs often make extensive use of matrices. For example, three-dimensional (3D) computer graphics software typically employs matrices to perform common transformations such as translation, scaling, and rotation. When using homogeneous coordinates, each of these operations can be efficiently represented using a single 4×4 matrix. Multiple transformations can also be applied by merging a series of distinct transformation matrices into a single transformation matrix using matrix multiplication. This combined matrix is typically applied to an array of object vertices that defines a 3D model. It is important for 3D computer graphics software to carry out operations such as matrix multiplication and matrix-vector multiplication as quickly as possible since a 3D model may contain thousands or even millions of object vertices.

The product of two matrices is defined as follows. Let **A** be an $m \times n$ matrix where m and n denote the number of rows and columns, respectively. Let **B** be an $n \times p$ matrix. Let **C** be the product of **A** and **B**, which is an $m \times p$ matrix. The value of each element $c(i, j)$ in **C** can be calculated using the following formula:

$$c_{ij} = \sum_{k=0}^{n-1} a_{ik} b_{kj} \quad i = 0, \dots, m-1; j = 0, \dots, p-1$$

Before proceeding to the sample code, a few comments are warranted. According to the definition of matrix multiplication, the number of columns in **A** *must* equal the number of rows in **B**. For example, if **A** is a 3×4 matrix and **B** is a 4×2 matrix, the product **AB** (a 3×2 matrix) can be calculated but **BA** is undefined. Also note that the value of each $c(i, j)$ in **C** is simply the dot product of row i in matrix **A** and column j in matrix **B**. The sample assembly language code will exploit this fact to perform matrix-matrix and matrix-vector multiplications using SIMD arithmetic. Finally, unlike most mathematical texts, the subscripts in the matrix multiplication equation use zero-based indexing. This simplifies translating the equation into C++ and assembly language code.

SsePackedFloatingPointMatrix4x4 is the name of the next sample program. This sample program demonstrates using the x86-SSE instruction set to perform matrix-matrix and matrix-vector multiplication using 4×4 matrices and 4×1 vectors. Listings 9-10 and 9-11 show the C++ and x86 assembly language source for sample program SsePackedFloatingPointMatrix4x4.

Listing 9-10. SsePackedFloatingPointMatrix4x4.cpp

```
#include "stdafx.h"
#include "SsePackedFloatingPointMatrix4x4.h"

// The functions Mat4x4Mul and Mat4x4MulVec are defined in
// the file CommonFiles\Mat4x4.cpp

void SsePfpMatrix4x4MultiplyCpp(Mat4x4 m_des, Mat4x4 m_src1, Mat4x4 m_src2)
{
    Mat4x4Mul(m_des, m_src1, m_src2);
}
```

```

void SsePfpMatrix4x4TransformVectorsCpp(Vec4x1* v_des, Mat4x4 m_src,
Vec4x1* v_src, int num_vec)
{
    for (int i= 0; i < num_vec; i++)
        Mat4x4MulVec(v_des[i], m_src, v_src[i]);
}

void SsePfpMatrix4x4Multiply(void)
{
    __declspec(align(16)) Mat4x4 m_src1;
    __declspec(align(16)) Mat4x4 m_src2;
    __declspec(align(16)) Mat4x4 m_des1;
    __declspec(align(16)) Mat4x4 m_des2;

    Mat4x4SetRow(m_src1, 0, 10.5, 11, 12, -13.625);
    Mat4x4SetRow(m_src1, 1, 14, 15, 16, 17.375);
    Mat4x4SetRow(m_src1, 2, 18.25, 19, 20.125, 21);
    Mat4x4SetRow(m_src1, 3, 22, 23.875, 24, 25);

    Mat4x4SetRow(m_src2, 0, 7, 1, 4, 8);
    Mat4x4SetRow(m_src2, 1, 14, -5, 2, 9);
    Mat4x4SetRow(m_src2, 2, 10, 9, 3, 6);
    Mat4x4SetRow(m_src2, 3, 2, 11, -14, 13);

    SsePfpMatrix4x4MultiplyCpp(m_des1, m_src1, m_src2);
    SsePfpMatrix4x4Multiply_(m_des2, m_src1, m_src2);

    printf("\nResults for SsePfpMatrix4x4Multiply()\n");
    Mat4x4Printf(m_src1, "\nMatrix m_src1\n");
    Mat4x4Printf(m_src2, "\nMatrix m_src2\n");
    Mat4x4Printf(m_des1, "\nMatrix m_des1\n");
    Mat4x4Printf(m_des2, "\nMatrix m_des2\n");
}

void SsePfpMatrix4x4TransformVectors(void)
{
    const int n = 8;
    __declspec(align(16)) Mat4x4 m_src;
    __declspec(align(16)) Vec4x1 v_src[n];
    __declspec(align(16)) Vec4x1 v_des1[n];
    __declspec(align(16)) Vec4x1 v_des2[n];

    Vec4x1Set(v_src[0], 10, 10, 10, 1);
    Vec4x1Set(v_src[1], 10, 11, 10, 1);
    Vec4x1Set(v_src[2], 11, 10, 10, 1);
    Vec4x1Set(v_src[3], 11, 11, 10, 1);
    Vec4x1Set(v_src[4], 10, 10, 12, 1);
    Vec4x1Set(v_src[5], 10, 11, 12, 1);
}

```



```

Vec4x1Set(v_src[6], 11, 10, 12, 1);
Vec4x1Set(v_src[7], 11, 11, 12, 1);

// m_src = scale(2, 3, 4)
Mat4x4SetRow(m_src, 0, 2, 0, 0, 0);
Mat4x4SetRow(m_src, 1, 0, 3, 0, 0);
Mat4x4SetRow(m_src, 2, 0, 0, 7, 0);
Mat4x4SetRow(m_src, 3, 0, 0, 0, 1);

SsePfpMatrix4x4TransformVectorsCpp(v_des1, m_src, v_src, n);
SsePfpMatrix4x4TransformVectors_(v_des2, m_src, v_src, n);

printf("\nResults for SsePfpMatrix4x4TransformVectors()\n");
Mat4x4Printf(m_src, "Matrix m_src\n");
printf("\n");

for (int i = 0; i < n; i++)
{
    const char* fmt = "%4s %4d: %12.6f %12.6f %12.6f %12.6f\n";
    printf(fmt, "v_src ", i, v_src[i][0], v_src[i][1], v_src[i][2], ↵
v_src[i][3]);
    printf(fmt, "v_des1 ", i, v_des1[i][0], v_des1[i][1], v_des1[i][2], ↵
v_des1[i][3]);
    printf(fmt, "v_des2 ", i, v_des2[i][0], v_des2[i][1], v_des2[i][2], ↵
v_des2[i][3]);
    printf("\n");
}
}

int _tmain(int argc, _TCHAR* argv[])
{
    SsePfpMatrix4x4Multiply();
    SsePfpMatrix4x4TransformVectors();

    SsePfpMatrix4x4MultiplyTimed();
    SsePfpMatrix4x4TransformVectorsTimed();
    return 0;
}

```

Listing 9-11. SsePackedFloatingPointMatrix4x4_.asm

```

.model flat,c
.code

; _Mat4x4Transpose macro
;
; Description: This macro computes the transpose of a 4x4
;             single-precision floating-point matrix.
;

```

```

;   Input Matrix           Output Matrix
;   xmm0   a3 a2 a1 a0    xmm4   d0 c0 b0 a0
;   xmm1   b3 b2 b1 b0    xmm5   d1 c1 b1 a1
;   xmm2   c3 c2 c1 c0    xmm6   d2 c2 b2 a2
;   xmm3   d3 d2 d1 d0    xmm7   d3 c3 b3 a3
;
; Note:   The row of a 4x4 matrix is reversed when loaded into an
;         XMM register due to x86 little-endian ordering.
;
; Requires: SSE

```

`_Mat4x4Transpose` macro

```

    movaps xmm4,xmm0
    unpcklps xmm4,xmm1           ;xmm4 = b1 a1 b0 a0
    unpckhps xmm0,xmm1           ;xmm0 = b3 a3 b2 a2
    movaps xmm5,xmm2
    unpcklps xmm5,xmm3           ;xmm5 = d1 c1 d0 c0
    unpckhps xmm2,xmm3           ;xmm2 = d3 c3 d2 c2

    movaps xmm1,xmm4
    movlhps xmm4,xmm5           ;xmm4 = d0 c0 b0 a0
    movhlps xmm5,xmm1           ;xmm5 = d1 c1 b1 a1
    movaps xmm6,xmm0
    movlhps xmm6,xmm2           ;xmm6 = d2 c2 b2 a2
    movaps xmm7,xmm2
    movhlps xmm7,xmm0           ;xmm7 = d3 c3 b2 a3
    endm

```

```

; extern "C" void SsePfpMatrix4x4Multiply_(Mat4x4 m_des, Mat4x4 m_src1, ←
Mat4x4 m_src2);

```

```

; Description: The following function computes the product of two
;             4x4 single-precision floating-point matrices.
;
; Requires: SSE4.1

```

`SsePfpMatrix4x4Multiply_proc`

```

    push ebp
    mov ebp,esp
    push ebx

```

```

; Compute transpose of m_src2 (m_src2_T)

```

```

    mov ebx,[ebp+16]           ;ebx = m_src2
    movaps xmm0,[ebx]
    movaps xmm1,[ebx+16]
    movaps xmm2,[ebx+32]
    movaps xmm3,[ebx+48]       ;xmm3:xmm0 = m_src2
                                ;xmm7:xmm4 = m_src2_T
    _Mat4x4Transpose

```

```

; Perform initializations for matrix product
    mov edx,[ebp+8]           ;edx = m_des
    mov ebx,[ebp+12]        ;ebx = m_src1
    mov ecx,4               ;ecx = number of rows
    xor eax,eax             ;eax = offset into arrays

; Repeat loop until matrix product is calculated.
    align 16
@@:   movaps xmm0,[ebx+eax]   ;xmm0 = row i of m_src1

; Compute dot product of m_src1 row i and m_src2_T row 0
    movaps xmm1,xmm0
    dpps xmm1,xmm4,11110001b ;xmm1[31:0] = dot product
    insertps xmm3,xmm1,00000000b ;xmm3[31:0] = xmm1[31:0]

; Compute dot product of m_src1 row i and m_src2_T row 1
    movaps xmm2,xmm0
    dpps xmm2,xmm5,11110001b ;xmm2[31:0] = dot product
    insertps xmm3,xmm2,00010000b ;xmm3[63:32] = xmm2[31:0]

; Compute dot product of m_src1 row i and m_src2_T row 2
    movaps xmm1,xmm0
    dpps xmm1,xmm6,11110001b ;xmm1[31:0] = dot product
    insertps xmm3,xmm1,00100000b ;xmm3[95:64] = xmm1[31:0]

; Compute dot product of m_src1 row i and m_src2_T row 3
    movaps xmm2,xmm0
    dpps xmm2,xmm7,11110001b ;xmm2[31:0] = dot product
    insertps xmm3,xmm2,00110000b ;xmm3[127:96] = xmm2[31:0]

; Save m_des.row i and update loop variables
    movaps [edx+eax],xmm3     ;save current row result
    add eax,16                ;set array offset to next row
    dec ecx
    jnz @B

    pop ebx
    pop ebp
    ret
SsePfpMatrix4x4Multiply_ endp

; extern void SsePfpMatrix4x4TransformVectors_(Vec4x1* v_des, Mat4x4 m_src,
Vec4x1* v_src, int num_vec);
;
; Description: The following function applies a transformation matrix
;              to an array 4x1 single-precision floating-point vectors.
;
; Requires:    SSE4.1

```

```

SsePfpMatrix4x4TransformVectors_ proc
    push ebp
    mov ebp,esp
    push esi
    push edi

; Make sure num_vec is valid
    mov ecx,[ebp+20]                ;ecx = num_vec
    test ecx,ecx
    jle Done                        ;jump if num_vec <= 0

; Load m_src into xmm3:xmm0
    mov eax,[ebp+12]                ;eax = pointer to m_src
    movaps xmm0,[eax]              ;xmm0 = row 0
    movaps xmm1,[eax+16]           ;xmm1 = row 1
    movaps xmm2,[eax+32]           ;xmm2 = row 2
    movaps xmm3,[eax+48]           ;xmm3 = row 3

; Initialize pointers to v_src and v_des
    mov esi,[ebp+16]                ;esi = pointer to v_src
    mov edi,[ebp+8]                 ;edi = pointer to v_des
    xor eax,eax                     ;eax = array offset

; Compute v_des[i] = m_src * v_src[i]
    align 16
@@:    movaps xmm4,[esi+eax]        ;xmm4 = vector v_src[i]

; Compute dot product of m_src row 0 and v_src[i]
    movaps xmm5,xmm4
    dpps xmm5,xmm0,11110001b        ;xmm5[31:0] = dot product
    insertps xmm7,xmm5,00000000b    ;xmm7[31:0] = xmm5[31:0]

; Compute dot product of m_src row 1 and v_src[i]
    movaps xmm6,xmm4
    dpps xmm6,xmm1,11110001b        ;xmm6[31:0] = dot product
    insertps xmm7,xmm6,00010000b    ;xmm7[63:32] = xmm6[31:0]

; Compute dot product of m_src row 2 and v_src[i]
    movaps xmm5,xmm4
    dpps xmm5,xmm2,11110001b        ;xmm5[31:0] = dot product
    insertps xmm7,xmm5,00100000b    ;xmm7[95:64] = xmm5[31:0]

; Compute dot product of m_src row 3 and v_src[i]
    movaps xmm6,xmm4
    dpps xmm6,xmm3,11110001b        ;xmm6[31:0] = dot product
    insertps xmm7,xmm6,00110000b    ;xmm7[127:96] = xmm6[31:0]

```

```

; Save v_des[i] and update loop variables
    movaps [edi+eax],xmm7           ;save transformed vector
    add eax,16
    dec ecx
    jnz @B

Done:   pop edi
        pop esi
        pop ebp
        ret
SsePfpMatrix4x4TransformVectors_ endp
        end

```

The C++ file `SsePackedFloatingPointMatrix4x4.cpp` (see Listing 9-10) contains a couple of test functions that demonstrate matrix-matrix multiplication and matrix-vector transformation. The function `SsePfpMatrix4x4Multiply` initializes a couple of test matrices. It then invokes C++ and assembly language versions of a matrix multiplication function. The results of these functions are then printed for comparison purposes. Note that some of C++ matrix functions are defined in a file named `Mat4x4.cpp`. This file is not shown here but is included as part of the downloadable source code. The function `SsePfpMatrix4x4TransformVectors` uses the same arrangement to demonstrate matrix-vector transformations.

The notable parts of sample program `SsePackedFloatingPointMatrix4x4` are contained in the assembly language file `SsePackedFloatingPointMatrix4x4.asm` (see Listing 9-11). Near the top of this file is a macro named `_Mat4x4Transpose`. A macro is an assembler text substitution mechanism that enables a programmer to represent a sequence of assembly language instructions, data definitions, or other statements using a single text string. During assembly of an x86 assembly language source code file, the assembler replaces any occurrence of the macro name with the statements that are declared between the `macro` and `endm` directives. Assembly language macros are typically employed to generate sequences of instructions that will be used more than once. Macros are also frequently used to avoid the performance overhead of a function call. You'll learn more about the macro processing capabilities of MASM throughout the remainder of this book.

The macro `_Mat4x4Transpose` declares a sequence of assembly language instructions that computes the transpose of a 4×4 matrix of single-precision floating-point values. The transpose of a matrix is defined as follows. If \mathbf{A} is an $m \times n$ matrix, the transpose of \mathbf{A} (denoted by \mathbf{B}) is an $n \times m$ matrix, where $b(i,j) = a(j,i)$. The macro `_Mat4x4Transpose` requires the source matrix to be loaded in registers XMM0-XMM3 and saves the transposed matrix in registers XMM4-XMM7. The actual transposition of the source matrix is performed using a combination of `movaps`, `unpcklps`, `unpckhps`, `movltps`, and `movhlps` instructions, as illustrated in Figure 9-2.

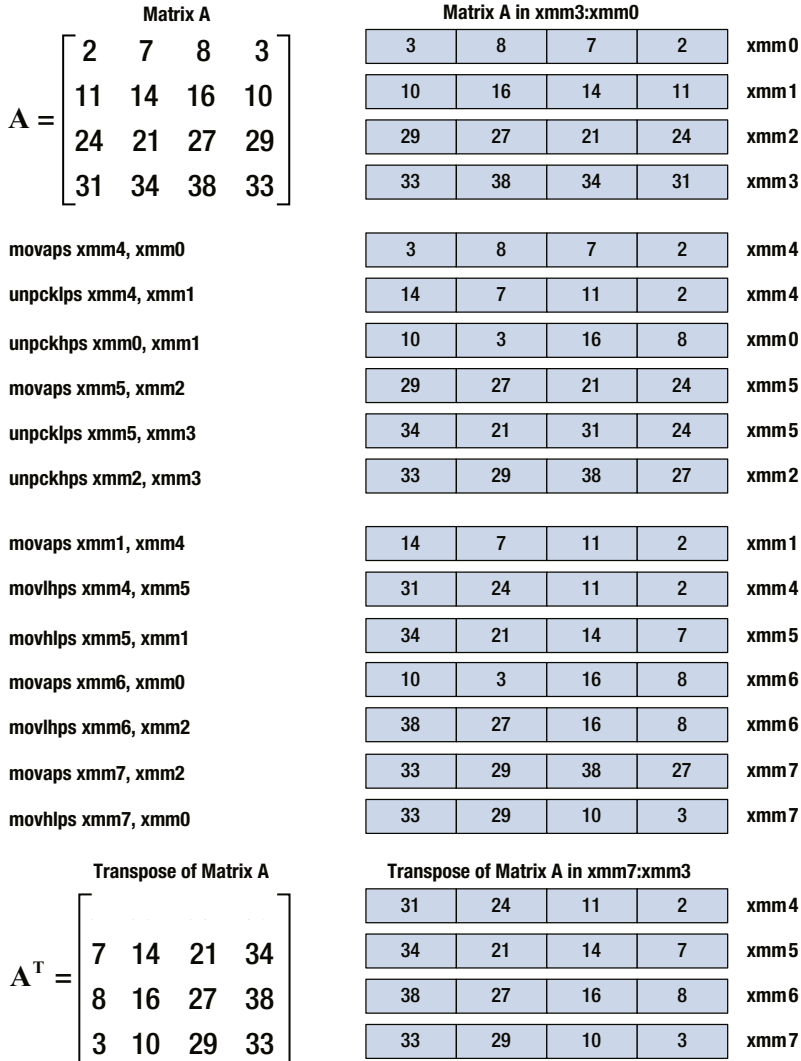

Figure 9-2. Instruction sequence used by macro `_Mat4x4Transpose` to transpose a 4×4 matrix of single-precision floating-point values

The function `SsePfpMatrix4x4Multiply_` uses the macro `_Mat4x4Transpose` to compute the product of two 4×4 matrices. Earlier in this section you learned that each $c(i,j)$ of the matrix product $C = AB$ is simply the dot product of row i in **A** and column j in **B**. This means that you can use the x86-SSE `dpps` (Dot Product of Packed Single-Precision Floating-Point Values) instruction to accelerate the multiplication of two 4×4 matrices. Recall that C++ uses row-major ordering to organize the elements of a two-dimensional

matrix in memory. The use of row-major ordering means that an entire row of a 4×4 single-precision floating-point matrix can be loaded into an XMM register using the `movaps` instruction. Unfortunately, there is no single x86-SSE instruction that can load the column of a matrix into an XMM register. The solution to the dilemma is to transpose one of the matrices since this facilitates use of the `dpps` instruction.

Take a closer look at the function `SsePfpMatrix4x4Multiply_`. Immediately following its prolog, the matrix `m_src2` is loaded into registers XMM0-XMM3 using a series of `movaps` instructions. The macro `_Mat4x4Transpose` is then employed to compute the transpose of matrix `m_src2`, which is represented by `m_src2_T`. (Figure 9-3 contains a portion of the MASM listing file that shows the expansion of macro `_Mat4x4Transpose`.) Next, registers EBX and EDX are initialized as pointers to `m_src1` and `m_des`, respectively. ECX is then initialized as a loop counter and EAX as a row offset value for both `m_src1` and `m_des`. At the top of the main processing loop, a `movaps xmm0, [ebx+eax]` instruction loads row 0 of `m_src1` into XMM0. Following a `movaps xmm1, xmm0` instruction, a `dpps xmm1, xmm4, 11110001b` instruction computes the dot product of `m_src1` row 0 and `m_src2_T` row 0. The upper four bits of the `dpps` immediate operand is a conditional mask that specifies which element pairs in XMM1 and XMM4 are multiplied. In this example, all four product pairs are computed (i.e., `xmm1[31:0] * xmm4[31:0]`, `xmm1[63:32] * xmm4[63:32]`, and so on). If a conditional mask bit position is equal to zero, a value of 0.0 is used for the result instead of the multiplicative product. The lower four bits of the `dpps` immediate operand are a broadcast mask that specifies whether the dot product result (bit = 1) or 0.0 is copied to the corresponding element in the destination operand.

```

00000000          SsePfpMatrix4x4Multiply_ proc
00000000 55                push ebp
00000001 8B EC            mov  ebp, esp
00000003 53                push ebx

                                ; Compute transpose of m_src2 (m_src2_T)
00000004 8B 5D 10          mov  ebx, [ebp+16]           ; ebx = m_src2
00000007 0F 28 03          movaps xmm0, [ebx]
0000000A 0F 28 4B 10        movaps xmm1, [ebx+16]
0000000E 0F 28 53 20        movaps xmm2, [ebx+32]
00000012 0F 28 5B 30        movaps xmm3, [ebx+48]     ; xmm3: xmm0 = m_src2
                                _Mat4x4Transpose ; xmm7: xmm4 = m_src2_T
00000016 0F 28 E0 1        movaps xmm4, xmm0
00000019 0F 14 E1 1        unpcklps xmm4, xmm1     ; xmm4 = b1 a1 b0 a0
0000001C 0F 15 C1 1        unpckhps xmm0, xmm1     ; xmm0 = b3 a3 b2 a2
0000001F 0F 28 EA 1        movaps xmm5, xmm2
00000022 0F 14 EB 1        unpcklps xmm5, xmm3     ; xmm5 = d1 c1 d0 c0
00000025 0F 15 D3 1        unpckhps xmm2, xmm3     ; xmm2 = d3 c3 d2 c2
00000028 0F 28 CC 1        movaps xmm1, xmm4
0000002B 0F 16 E5 1        movlhps xmm4, xmm5     ; xmm4 = d0 c0 b0 a0
0000002E 0F 12 E9 1        movhlps xmm5, xmm1     ; xmm5 = d1 c1 b1 a1
00000031 0F 28 F0 1        movaps xmm6, xmm0
00000034 0F 16 F2 1        movlhps xmm6, xmm2     ; xmm6 = d2 c2 b2 a2
00000037 0F 28 FA 1        movaps xmm7, xmm2
0000003A 0F 12 F8 1        movhlps xmm7, xmm0     ; xmm7 = d3 c3 b2 a3

                                ; Perform initializations for matrix product
0000003D 8B 55 08          mov  edx, [ebp+8]         ; edx = m_des
00000040 8B 5D 0C          mov  ebx, [ebp+12]       ; ebx = m_src1

```

Figure 9-3. Expansion of macro `_Mat4x4Transpose`

An `insertps xmm3,xmm1,0000000b` instruction copies the computed dot product into the correct elemental position of `m_des` that is maintained in XMM3. Bits 7:6 of the `insertps` immediate operand specify which source operand element to copy; bits 5:4 specify the destination operand element. Bits 3:0 are used as a zero mask to conditionally set a destination operand element to zero. The next set of `movaps`, `dpps`, and `insertps` instructions calculates and saves the dot product of `m_src1` row 0 and `m_src2_T` row 1. This dot product computation pattern is repeated using the rows of `m_src1` and `m_src2_T` until all 16 required dot products have been calculated and saved.

The assembly language file `SsePackedFloatingPointMatrix4x4.asm` also contains a function named `SsePfpMatrix4x4TransformVectors_`. This function applies a 4×4 transformation matrix to each vector in an array of 4×1 vectors. It also uses the `dpps` instruction to accelerate the process of multiplying a 4×4 matrix by a 4×1 vector. Output 9-5 shows the results of the `SsePackedFloatingPointMatrix4x4` sample program. Tables 9-2 and 9-3 contain some timing measurements for comparison purposes. The source code for the timing measurements is not shown here but is included as part of the downloadable sample code file.

Table 9-2. Mean Execution Times (in Microseconds) for `SsePfpMatrix4x4Multiply` Functions (2,000 Matrix Multiplications)

CPU	C++	X86-SSE
Intel Core i7-4770	50	31
Intel Core i7-4600U	64	41
Intel Core i3-2310M	97	68

Table 9-3. Mean Execution Times (in Microseconds) for `SsePfpMatrix4x4TransformVectors` Functions (10,000 Vector Transformations)

CPU	C++	X86-SSE
Intel Core i7-4770	43	26
Intel Core i7-4600U	55	31
Intel Core i3-2310M	91	63

Output 9-5. Sample Program `SsePackedFloatingPointMatrix4x4`

Results for `SsePfpMatrix4x4Multiply()`

```
Matrix m_src1
  10.500000    11.000000    12.000000    -13.625000
  14.000000    15.000000    16.000000    17.375000
  18.250000    19.000000    20.125000    21.000000
  22.000000    23.875000    24.000000    25.000000
```

Matrix m_src2

7.000000	1.000000	4.000000	8.000000
14.000000	-5.000000	2.000000	9.000000
10.000000	9.000000	3.000000	6.000000
2.000000	11.000000	-14.000000	13.000000

Matrix m_des1

320.250000	-86.375000	290.750000	77.875000
502.750000	274.125000	-109.250000	568.875000
637.000000	335.375000	-122.625000	710.750000
778.250000	393.625000	-142.250000	859.875000

Matrix m_des2

320.250000	-86.375000	290.750000	77.875000
502.750000	274.125000	-109.250000	568.875000
637.000000	335.375000	-122.625000	710.750000
778.250000	393.625000	-142.250000	859.875000

Results for SsePfpMatrix4x4TransformVectors()

Matrix m_src

2.000000	0.000000	0.000000	0.000000
0.000000	3.000000	0.000000	0.000000
0.000000	0.000000	7.000000	0.000000
0.000000	0.000000	0.000000	1.000000

v_src	0:	10.000000	10.000000	10.000000	1.000000
v_des1	0:	20.000000	30.000000	70.000000	1.000000
v_des2	0:	20.000000	30.000000	70.000000	1.000000

v_src	1:	10.000000	11.000000	10.000000	1.000000
v_des1	1:	20.000000	33.000000	70.000000	1.000000
v_des2	1:	20.000000	33.000000	70.000000	1.000000

v_src	2:	11.000000	10.000000	10.000000	1.000000
v_des1	2:	22.000000	30.000000	70.000000	1.000000
v_des2	2:	22.000000	30.000000	70.000000	1.000000

v_src	3:	11.000000	11.000000	10.000000	1.000000
v_des1	3:	22.000000	33.000000	70.000000	1.000000
v_des2	3:	22.000000	33.000000	70.000000	1.000000

v_src	4:	10.000000	10.000000	12.000000	1.000000
v_des1	4:	20.000000	30.000000	84.000000	1.000000
v_des2	4:	20.000000	30.000000	84.000000	1.000000

v_src	5:	10.000000	11.000000	12.000000	1.000000
v_des1	5:	20.000000	33.000000	84.000000	1.000000
v_des2	5:	20.000000	33.000000	84.000000	1.000000
v_src	6:	11.000000	10.000000	12.000000	1.000000
v_des1	6:	22.000000	30.000000	84.000000	1.000000
v_des2	6:	22.000000	30.000000	84.000000	1.000000
v_src	7:	11.000000	11.000000	12.000000	1.000000
v_des1	7:	22.000000	33.000000	84.000000	1.000000
v_des2	7:	22.000000	33.000000	84.000000	1.000000

Results for SsePfpMatrix4x4MultiplyTimed()

Benchmark times saved to __SsePfpMatrix4x4MultiplyTimed.csv

Results for SsePfpMatrix4x4TransformVectorsTimed()

Benchmark times saved to __SsePfpMatrix4x4TransformVectorsTimed.csv

■ **Note** If you run a sample program using the Visual Studio IDE, any program-generated result files are saved in the folder Chapter##\<ProgramName>\<ProgramName>, where ## denotes the chapter number and <ProgramName> represents the name of the sample program.

Using the x86-SSE instruction set to perform matrix multiplication produced a 30-38 percent improvement in performance depending on the target processor. The x86-SSE matrix-vector multiplication function also generated a noteworthy performance improvement of 31-40 percent.

Summary

This chapter focused on the packed floating-point capabilities of x86-SSE. You learned how to perform basic arithmetic operations using 128-bit wide packed floating-point operands. You also examined some sample code that demonstrated practical SIMD processing techniques using floating-point arrays and 4×4 matrices. In the next chapter, you'll learn how to create assembly language functions that exploit the packed integer resources of x86-SSE.



X86-SSE Programming – Packed Integers

In Chapter 6 you learned how to manipulate packed integers using the computational resources of MMX. In this chapter, you learn how to process packed integers using the computational resources of x86-SSE. The first sample program highlights using the x86-SSE instruction set to perform basic packed integer operations with the XMM registers. You'll learn rather quickly that working with the 128-bit wide XMM registers to perform packed integer operations is not that much different than using the 64-bit wide MMX registers. The last two sample programs explain how to use the x86-SSE instruction set to perform common image-processing tasks, including histogram construction and grayscale image thresholding.

Like the previous two chapters, the sample code in this chapter uses various levels of x86-SSE. The documentation header of each assembly language function lists the required x86-SSE extension. You can verify the level of x86-SSE supported by your PC using one of the software utilities listed in Appendix C.

Packed Integer Fundamentals

The first x86-SSE packed integer sample program that you study is named `SsePackedIntegerFundamentals`. The purpose of this sample program is to demonstrate how to perform common packed integer operations using the XMM registers. The C++ and assembly language source code for sample program `SsePackedIntegerFundamentals` is shown in Listings 10-1 and 10-2.

Listing 10-1. `SsePackedIntegerFundamentals.cpp`

```
#include "stdafx.h"
#include "XmmVal.h"

extern "C" void SsePiAddI16_(const XmmVal* a, const XmmVal* b, XmmVal c[2]);
extern "C" void SsePiSubI32_(const XmmVal* a, const XmmVal* b, XmmVal* c);
extern "C" void SsePiMul32_(const XmmVal* a, const XmmVal* b, XmmVal c[2]);
```

```

void SsePiAddI16(void)
{
    _declspec(align(16)) XmmVal a;
    _declspec(align(16)) XmmVal b;
    _declspec(align(16)) XmmVal c[2];
    char buff[256];

    a.i16[0] = 10;           b.i16[0] = 100;
    a.i16[1] = 200;         b.i16[1] = -200;
    a.i16[2] = 30;          b.i16[2] = 32760;
    a.i16[3] = -32766;      b.i16[3] = -400;
    a.i16[4] = 50;          b.i16[4] = 500;
    a.i16[5] = 60;          b.i16[5] = -600;
    a.i16[6] = 32000;       b.i16[6] = 1200;
    a.i16[7] = -32000;      b.i16[7] = -950;

    SsePiAddI16_(&a, &b, c);

    printf("\nResults for SsePiAddI16\n");
    printf("a:  %s\n", a.ToString_i16(buff, sizeof(buff)));
    printf("b:  %s\n", b.ToString_i16(buff, sizeof(buff)));
    printf("c[0]: %s\n", c[0].ToString_i16(buff, sizeof(buff)));
    printf("\n");
    printf("a:  %s\n", a.ToString_i16(buff, sizeof(buff)));
    printf("b:  %s\n", b.ToString_i16(buff, sizeof(buff)));
    printf("c[1]: %s\n", c[1].ToString_i16(buff, sizeof(buff)));
}

void SsePiSubI32(void)
{
    _declspec(align(16)) XmmVal a;
    _declspec(align(16)) XmmVal b;
    _declspec(align(8)) XmmVal c;           // Misaligned XmmVal
    char buff[256];

    a.i32[0] = 800;           b.i32[0] = 250;
    a.i32[1] = 500;           b.i32[1] = -2000;
    a.i32[2] = 1000;          b.i32[2] = -40;
    a.i32[3] = 900;           b.i32[3] = 1200;

    SsePiSubI32_(&a, &b, &c);

    printf("\nResults for SsePiSubI32\n");
    printf("a: %s\n", a.ToString_i32(buff, sizeof(buff)));
    printf("b: %s\n", b.ToString_i32(buff, sizeof(buff)));
    printf("c: %s\n", c.ToString_i32(buff, sizeof(buff)));
}

```

```

void SsePiMul32(void)
{
    __declspec(align(16)) XmmVal a;
    __declspec(align(16)) XmmVal b;
    __declspec(align(16)) XmmVal c[2];
    char buff[256];

    a.i32[0] = 10;          b.i32[0] = 100;
    a.i32[1] = 20;          b.i32[1] = -200;
    a.i32[2] = -30;         b.i32[2] = 300;
    a.i32[3] = -40;         b.i32[3] = -400;

    SsePiMul32_(&a, &b, c);

    printf("\nResults for SsePiMul32\n");
    printf("a:   %s\n", a.ToString_i32(buff, sizeof(buff)));
    printf("b:   %s\n", b.ToString_i32(buff, sizeof(buff)));
    printf("c[0]: %s\n", c[0].ToString_i32(buff, sizeof(buff)));
    printf("\n");
    printf("a:   %s\n", a.ToString_i32(buff, sizeof(buff)));
    printf("b:   %s\n", b.ToString_i32(buff, sizeof(buff)));
    printf("c[1]: %s\n", c[1].ToString_i64(buff, sizeof(buff)));
}

int _tmain(int argc, _TCHAR* argv[])
{
    SsePiAddI16();
    SsePiSubI32();
    SsePiMul32();
    return 0;
}

```

Listing 10-2. SsePackedIntegerFundamentals.asm

```

.model flat,c
.code

; extern "C" void SsePiAddI16_(const XmmVal* a, const XmmVal* b, XmmVal c[2]);
;
; Description: The following function demonstrates packed signed word
;              addition using wraparound and saturated modes.
;
; Requires:    SSE2

SsePiAddI16_ proc
    push ebp
    mov ebp,esp

```

```

; Initialize
    mov eax,[ebp+8]           ;eax = pointer to a
    mov ecx,[ebp+12]        ;ecx = pointer to b
    mov edx,[ebp+16]        ;edx = pointer to c

; Load XmmVals a and b
    movdqa xmm0,[eax]       ;xmm0 = a
    movdqa xmm1,xmm0
    movdqa xmm2,[ecx]       ;xmm2 = b

; Perform packed word additions
    paddw xmm0,xmm2         ;packed add - wraparound
    paddsw xmm1,xmm2        ;packed add - saturated

; Save results
    movdqa [edx],xmm0       ;save c[0]
    movdqa [edx+16],xmm1    ;save c[1]

    pop ebp
    ret
SsePiAddI16_ endp

; extern "C" void SsePiSubI32_(const XmmVal* a, const XmmVal* b, XmmVal* c);
;
; Description: The following function demonstrates packed signed
;              doubleword subtraction.
;
; Requires:    SSE2

SsePiSubI32_ proc
    push ebp
    mov ebp,esp

; Initialize
    mov eax,[ebp+8]           ;eax = pointer to a
    mov ecx,[ebp+12]        ;ecx = pointer to b
    mov edx,[ebp+16]        ;edx = pointer to c

; Perform packed doubleword subtraction
    movdqa xmm0,[eax]       ;xmm0 = a
    psubd xmm0,[ecx]        ;xmm0 = a - b
    movdqu [edx],xmm0       ;save result to unaligned mem

    pop ebp
    ret
SsePiSubI32_ endp

```

```

; extern "C" void SsePiMul32_(const XmmVal* a, const XmmVal* b, XmmVal c[2]);
;
; Description: The following function demonstrates packed doubleword
;             multiplication.
;
; Requires:   SSE4.1

SsePiMul32_ proc
    push ebp
    mov ebp,esp

; Initialize
    mov eax,[ebp+8]           ;eax = pointer to a
    mov ecx,[ebp+12]        ;ecx = pointer to b
    mov edx,[ebp+16]        ;edx = pointer to c

; Load values and perform the multiplication
    movdqa xmm0,[eax]       ;xmm0 = a
    movdqa xmm1,[ecx]       ;xmm1 = b

    movdqa xmm2,xmm0
    pmulld xmm0,xmm1        ;signed dword mul - low result
    pmuldq xmm2,xmm1        ;signed dword mul - qword result

    movdqa [edx],xmm0       ;c[0] = pmulld result
    movdqa [edx+16],xmm2    ;c[1] = pmuldq result

    pop ebp
    ret
SsePiMul32_ endp
end

```

The C++ file `SsePackedIntegerFundamentals.cpp` (see Listing 10-1) contains three test functions that exemplify packed integer addition, subtraction, and multiplication using the x86-SSE instruction set. The first function, named `SsePiAddI16`, initializes a couple of `XmmVal` instances using 16-bit signed integers. It then invokes an assembly language function to perform packed integer addition using both wraparound and saturated arithmetic. The second test function, called `SsePiSubI32`, readies a few `XmmVal` variables in order to illustrate packed integer subtraction using 32-bit signed integers. Note that in this function, the `XmmVal` variable `c` is deliberately misaligned in order to demonstrate use of an unaligned data transfer instruction. `SsePiMul32` is the name of the final test function, which primes a couple of `XmmVal` variables for packed 32-bit integer multiplication.

The assembly language file `SsePackedIntegerFundamentals.asm` (see Listing 10-2) contains the corresponding assembly language functions. Following its prolog, the function `SsePiAddI16_` loads the argument values `a`, `b`, and `c` into registers `EAX`, `ECX`, and `EDX`, respectively. A `movdqa xmm0,[eax]` (Move Aligned Double Quadword) instruction

loads *a* into XMM0. As implied by its name, the `movdqa` instruction requires any memory operand that it references to be properly aligned on a 16-byte boundary. A `movdqa xmm1, xmm0` is then used to copy the contents of XMM0 into XMM1. This is followed by a `movdqa xmm2, [ecx]` instruction that loads *b* into XMM2. The instructions `paddw` and `paddsw` perform packed 16-bit signed integer addition using wraparound and saturated arithmetic, respectively. The results are then saved to the caller-specified array using a set of `movdqa` instructions.

The function `SsePiSub32_` uses the `psubd` instruction to perform packed subtraction using doubleword signed integers. Note that the result is saved to memory using a `movdqu` (Move Unaligned Double Quadword) instruction. The destination operand of this instruction corresponds to the `XmmVal` that was intentionally misaligned in the C++ function `SsePiSubI32`. Using a `movdqa` instruction here would cause the processor to generate an exception. The final assembly language function, `SsePiMul32_`, illustrates packed doubleword signed integer multiplication. Note that the x86-SSE instruction set supports two different forms of packed doubleword signed integer multiplication. The `pmulld` (Multiply Packed Signed Dword Integers and Store Low Result) instruction performs signed integer multiplication using 32-bit values and saves the low-order 32 bits of each product. The `pmuldq` (Multiply Packed Signed Dword Integers) instruction computes `des[63:0] = des[31:0] * src[31:0]` and `des[127:64] = des[95:64] * src[95:64]` using signed integer multiplication and saves the entire 64-bit (quadword) product. Output 10-1 shows the results of the `SsePackedIntegerFundamentals` sample program.

Output 10-1. Sample Program `SsePackedIntegerFundamentals`

Results for `SsePiAddI16_`

a:	10	200	30	-32766		50	60	32000	-32000
b:	100	-200	32760	-400		500	-600	1200	-950
c[0]:	110	0	-32746	32370		550	-540	-32336	32586

a:	10	200	30	-32766		50	60	32000	-32000
b:	100	-200	32760	-400		500	-600	1200	-950
c[1]:	110	0	32767	-32768		550	-540	32767	-32768

Results for `SsePiSubI32_`

a:	800	500		1000	900
b:	250	-2000		-40	1200
c:	550	2500		1040	-300

Results for `SsePiMul32_`

a:	10	20		-30	-40
b:	100	-200		300	-400
c[0]:	1000	-4000		-9000	16000

a:	10	20		-30	-40
b:	100	-200		300	-400
c[1]:	1000				-9000

Advanced Packed Integer Programming

The packed integer capabilities of x86-SSE are frequently used to accelerate the performance of common algorithms in image processing and computer graphics. In this section, you learn how to construct an image histogram using the x86-SSE instruction set. You also examine a sample program that performs image thresholding using SIMD processing techniques.

Packed Integer Histogram

The next sample program that you study is called `SsePackedIntegerHistogram`, which builds a histogram of intensity values for an image containing 8-bit grayscale pixels. Figure 10-1 shows a sample grayscale image and its histogram. This program also demonstrates how to dynamically allocate a memory buffer that is properly aligned for use with the x86-SSE instruction set. Listings 10-3 and 10-4 show the C++ and assembly language source code for the `SsePackedIntegerHistogram` sample program.

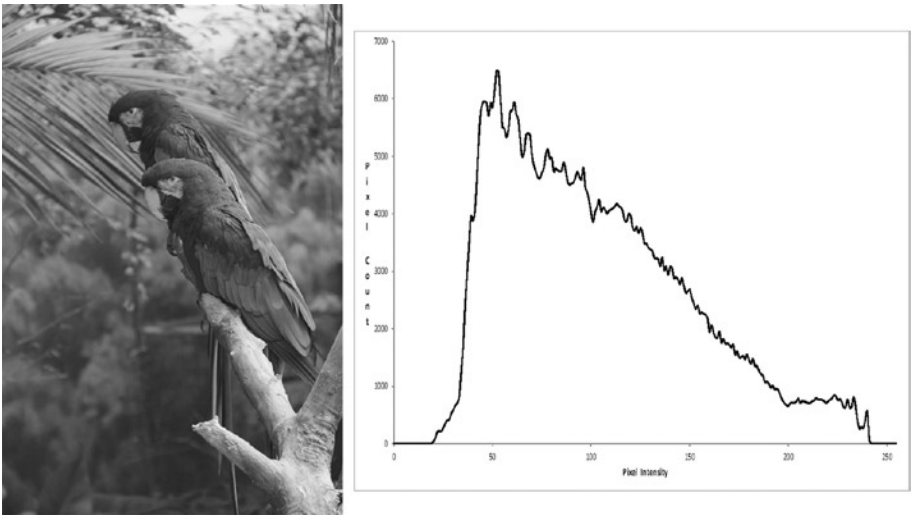

Figure 10-1. Sample grayscale image and its histogram

Listing 10-3. `SsePackedIntegerHistogram.cpp`

```
#include "stdafx.h"
#include "SsePackedIntegerHistogram.h"
#include <string.h>
#include <malloc.h>

extern "C" Uint32 NUM_PIXELS_MAX = 16777216;
```

```

bool SsePiHistogramCpp(UINT32* histo, const Uint8* pixel_buff, Uint32 num_pixels)
{
    // Make sure num_pixels is valid
    if ((num_pixels > NUM_PIXELS_MAX) || (num_pixels % 32 != 0))
        return false;

    // Make sure histo is aligned to a 16-byte boundary
    if (((uintptr_t)histo & 0xf) != 0)
        return false;

    // Make sure pixel_buff is aligned to a 16-byte boundary
    if (((uintptr_t)pixel_buff & 0xf) != 0)
        return false;

    // Build the histogram
    memset(histo, 0, 256 * sizeof(Uint32));

    for (Uint32 i = 0; i < num_pixels; i++)
        histo[pixel_buff[i]]++;

    return true;
}

void SsePiHistogram(void)
{
    const wchar_t* image_fn = L"..\\..\\..\\DataFiles\\TestImage1.bmp";
    const char* csv_fn = "__TestImage1_Histograms.csv";

    ImageBuffer ib(image_fn);
    Uint32 num_pixels = ib.GetNumPixels();
    Uint8* pixel_buff = (Uint8*)ib.GetPixelBuffer();
    Uint32* histo1 = (Uint32*)_aligned_malloc(256 * sizeof(Uint32), 16);
    Uint32* histo2 = (Uint32*)_aligned_malloc(256 * sizeof(Uint32), 16);
    bool rc1, rc2;

    rc1 = SsePiHistogramCpp(histo1, pixel_buff, num_pixels);
    rc2 = SsePiHistogram_(histo2, pixel_buff, num_pixels);

    printf("Results for SsePiHistogram()\n");

    if (!rc1 || !rc2)
    {
        printf(" Bad return code: rc1=%d, rc2=%d\n", rc1, rc2);
        return;
    }
}

```

```

FILE* fp;
bool compare_error = false;

if (fopen_s(&fp, csv_fn, "wt") != 0)
    printf(" File open error: %s\n", csv_fn);
else
{
    for (UInt32 i = 0; i < 256; i++)
    {
        fprintf(fp, "%u, %u, %u\n", i, histo1[i], histo2[i]);

        if (histo1[i] != histo2[i])
        {
            printf(" Histogram compare error at index %u\n", i);
            printf(" counts: [%u, %u]\n", histo1[i], histo2[i]);
            compare_error = true;
        }
    }

    if (!compare_error)
        printf(" Histograms are identical\n");

    fclose(fp);
}
}

int _tmain(int argc, _TCHAR* argv[])
{
    try
    {
        SsePiHistogram();
        SsePiHistogramTimed();
    }

    catch (...)
    {
        printf("Unexpected exception has occurred!\n");
        printf("File: %s (_tmain)\n", __FILE__);
    }

    return 0;
}

```

Listing 10-4. SsePackedIntegerHistogram_.asm

```

.model flat,c
.code
extern NUM_PIXELS_MAX:dword

; extern bool SsePiHistogram_(Uint32* histo, const Uint8* pixel_buff, ←
Uint32 num_pixels);
;
; Description: The following function builds an image histogram.
;
; Returns:      0 = invalid argument value
;              1 = success
;
; Requires:    SSE4.1

SsePiHistogram_ proc
    push ebp
    mov ebp,esp
    and esp,0FFFFFF0H           ;align ESP to 16 byte boundary
    sub esp,1024                ;allocate histo2
    mov edx,esp                 ;edx = histo2
    push ebx
    push esi
    push edi

; Make sure num_pixels is valid
    xor eax,eax                 ;set error return code
    mov ecx,[ebp+16]            ;ecx = num_pixels
    cmp ecx,[NUM_PIXELS_MAX]
    ja Done                     ;jump if num_pixels too big
    test ecx,1fh
    jnz Done                     ;jump if num_pixels % 32 != 0

; Make sure histo & pixel_buff are properly aligned
    mov ebx,[ebp+8]             ;ebx = histo
    test ebx,0fh
    jnz Done                     ;jump if misaligned
    mov esi,[ebp+12]            ;esi = pixel_buff
    test esi,0fh
    jnz Done                     ;jump if misaligned

; Initialize the histogram buffers (set all entries to zero)
    mov edi,ebx                 ;edi = histo
    mov ecx,256
    rep stosd                   ;initialize histo
    mov edi,edx                 ;edi = histo2
    mov ecx,256
    rep stosd                   ;initialize histo2

```

```

; Perform processing loop initializations
    mov edi,edx                                ;edi = histo2
    mov ecx,[ebp+16]                          ;ecx = number of pxiels
    shr ecx,5                                 ;ecx = number of pixel blocks

; Build the histograms
; Register usage: ebx = histo, edi = histo2, esi = pixel_buff
    align 16                                  ;align jump target
@@:    movdqa xmm0,[esi]                      ;load pixel block
    movdqa xmm2,[esi+16]                    ;load pixel block
    movdqa xmm1,xmm0
    movdqa xmm3,xmm2

; Process pixels 0 - 3
    pextrb eax,xmm0,0                        ;extract & count pixel 0
    add dword ptr [ebx+eax*4],1
    pextrb edx,xmm1,1                        ;extract & count pixel 1
    add dword ptr [edi+edx*4],1
    pextrb eax,xmm0,2                        ;extract & count pixel 2
    add dword ptr [ebx+eax*4],1
    pextrb edx,xmm1,3                        ;extract & count pixel 3
    add dword ptr [edi+edx*4],1

; Process pixels 4 - 7
    pextrb eax,xmm0,4                        ;extract & count pixel 4
    add dword ptr [ebx+eax*4],1
    pextrb edx,xmm1,5                        ;extract & count pixel 5
    add dword ptr [edi+edx*4],1
    pextrb eax,xmm0,6                        ;extract & count pixel 6
    add dword ptr [ebx+eax*4],1
    pextrb edx,xmm1,7                        ;extract & count pixel 7
    add dword ptr [edi+edx*4],1

; Process pixels 8 - 11
    pextrb eax,xmm0,8                        ;extract & count pixel 8
    add dword ptr [ebx+eax*4],1
    pextrb edx,xmm1,9                        ;extract & count pixel 9
    add dword ptr [edi+edx*4],1
    pextrb eax,xmm0,10                       ;extract & count pixel 10
    add dword ptr [ebx+eax*4],1
    pextrb edx,xmm1,11                       ;extract & count pixel 11
    add dword ptr [edi+edx*4],1

; Process pixels 12 - 15
    pextrb eax,xmm0,12                       ;extract & count pixel 12
    add dword ptr [ebx+eax*4],1
    pextrb edx,xmm1,13                       ;extract & count pixel 13
    add dword ptr [edi+edx*4],1

```

```

    pextrb eax,xmm0,14           ;extract & count pixel 14
    add dword ptr [ebx+eax*4],1
    pextrb edx,xmm1,15         ;extract & count pixel 15
    add dword ptr [edi+edx*4],1

; Process pixels 16 - 19
    pextrb eax,xmm2,0           ;extract & count pixel 16
    add dword ptr [ebx+eax*4],1
    pextrb edx,xmm3,1         ;extract & count pixel 17
    add dword ptr [edi+edx*4],1
    pextrb eax,xmm2,2         ;extract & count pixel 18
    add dword ptr [ebx+eax*4],1
    pextrb edx,xmm3,3         ;extract & count pixel 19
    add dword ptr [edi+edx*4],1

; Process pixels 20 - 23
    pextrb eax,xmm2,4           ;extract & count pixel 20
    add dword ptr [ebx+eax*4],1
    pextrb edx,xmm3,5         ;extract & count pixel 21
    add dword ptr [edi+edx*4],1
    pextrb eax,xmm2,6         ;extract & count pixel 22
    add dword ptr [ebx+eax*4],1
    pextrb edx,xmm3,7         ;extract & count pixel 23
    add dword ptr [edi+edx*4],1

; Process pixels 24 - 27
    pextrb eax,xmm2,8           ;extract & count pixel 24
    add dword ptr [ebx+eax*4],1
    pextrb edx,xmm3,9         ;extract & count pixel 25
    add dword ptr [edi+edx*4],1
    pextrb eax,xmm2,10        ;extract & count pixel 26
    add dword ptr [ebx+eax*4],1
    pextrb edx,xmm3,11        ;extract & count pixel 27
    add dword ptr [edi+edx*4],1

; Process pixels 28 - 31
    pextrb eax,xmm2,12         ;extract & count pixel 28
    add dword ptr [ebx+eax*4],1
    pextrb edx,xmm3,13        ;extract & count pixel 29
    add dword ptr [edi+edx*4],1
    pextrb eax,xmm2,14        ;extract & count pixel 30
    add dword ptr [ebx+eax*4],1
    pextrb edx,xmm3,15        ;extract & count pixel 31
    add dword ptr [edi+edx*4],1

    add esi,32                 ;esi = ptr next pixel block
    sub ecx,1                  ;update counter
    jnz @B                     ;repeat loop if not done

```

```

; Add histo2 to histo for final histogram. Note that each loop iteration
; adds 8 histogram entries.
    mov ecx,32                ;ecx = number of iterations
    xor eax,eax              ;eax = offset for histo arrays

@@:   movdqa xmm0,xmmword ptr [ebx+eax] ;load histo counts
      movdqa xmm1,xmmword ptr [ebx+eax+16]

      paddq xmm0,xmmword ptr [edi+eax] ;add counts from histo2
      paddq xmm1,xmmword ptr [edi+eax+16]

      movdqa xmmword ptr [ebx+eax],xmm0 ;save final histo counts
      movdqa xmmword ptr [ebx+eax+16],xmm1

      add eax,32              ;update array offset
      sub ecx,1              ;update counter
      jnz @B                  ;repeat loop if not done
      mov eax,1              ;set success return code

Done:  pop edi
      pop esi
      pop ebx
      mov esp,ebp
      pop ebp
      ret
SsePiHistogram_ endp
end

```

Near the top of the `SsePackedIntegerHistogram.cpp` file (see Listing 10-3) is a function named `SsePiHistogramCpp`, which constructs an image histogram using C++. The function begins by checking `num_pixels` to ensure that it's not greater than `NUM_PIXELS_MAX` and evenly divisible by 32 (the divisibility test is performed in order to match the logic in the corresponding assembly language histogram function). Next, the addresses of `histo` and `pixel_buff` are verified for proper alignment. A call to `memset` initializes each pixel count in the histogram buffer to zero. Construction of the histogram is then performed using a simple for loop.

The function `SsePiHistogram` uses a C++ class named `ImageBuffer` to load the pixels of an image file into memory. (The source code for class `ImageBuffer` is not shown but is included as part of the downloadable sample code file.) The variables `num_pixels` and `pixel_buff` are then initialized using member functions of class `ImageBuffer`. Next, two histogram buffers are dynamically allocated using the Visual C++ run-time function `_aligned_malloc`. This function includes an extra parameter that enables the caller to specify an alignment boundary for the allocated memory block. The next two statements invoke the C++ and assembly language histogram functions. The remaining code in `SsePiHistogram` compares the two histograms for equality and writes the results to a .CSV file.

The x86-SSE assembly language version of the histogram function is named `SsePiHistogram_` and is located in the file `SsePackedIntegerHistogram_.asm` (see Listing 10-4). Unlike its C++ counterpart, `SsePiHistogram_` constructs two partial histograms synchronously. It then merges these intermediate histograms to form the final image histogram. In order to implement this algorithm, `SsePiHistogram_` must allocate a second histogram buffer. This is performed as part of the function's prolog. Subsequent to the standard `push ebp` and `mov ebp,esp` instructions, an `and esp,0FFFFFF0H` instruction aligns ESP to a 16-byte boundary. This is followed by a `sub esp,1024` instruction, which allocates storage space on the stack for the second histogram buffer. The remainder of the prolog saves non-volatile registers EBX, ESI, and EDI on the stack. Figure 10-2 illustrates organization of the stack after the `push edi` instruction.

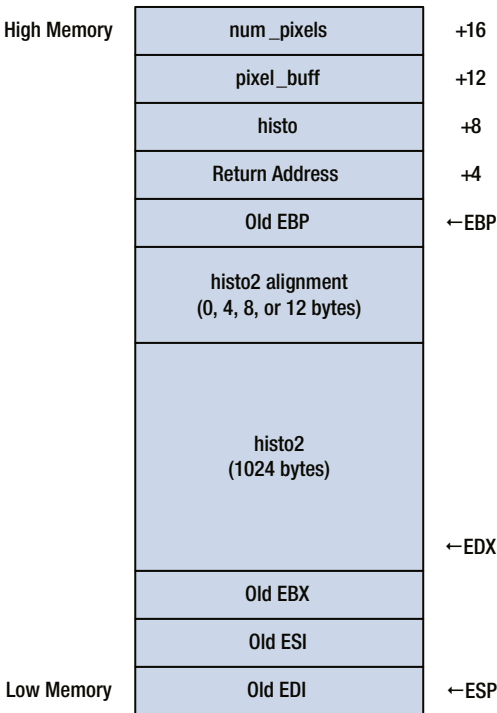

Figure 10-2. Organization of the stack in function `SsePiHistogram_` following the prolog

Following its prolog, the function `SsePiHistogram_` performs the same argument error checking that the C++ version performed, including verification of `num_pixels` and proper alignment confirmation of `histo` and `pixel_buff`. It then initializes the counts in both histogram buffers to zero using the `rep stosd` instruction. Prior to the main processing loop, register EBX points to `histo`, EDI to `histo2`, and ESI to `pixel_buff`. Register ECX also contains the number of 32-byte pixel blocks in the image.

At the top of the main processing loop, two `movdqa` instructions load the next 32 pixels into registers `XMM0` and `XMM2`. The packed pixel values are also duplicated in `XMM1` and `XMM3` to improve performance. A `pextrb eax, xmm0, 0` (Extract Byte) instruction extracts byte (or pixel) number 0 from `XMM0` and copies it to the low-order byte of register `EAX` (the high-order bits of `EAX` are set to zero). An `add dword ptr [ebx+eax*4], 1` instruction adds 1 to the appropriate histogram entry in `histo`. The `pextrb edx, xmm0, 1` instruction that follows extracts byte number 1 from `XMM0`, and an `add dword ptr [edi+edx*4], 1` instruction updates the appropriate histogram entry in `histo2`. This chain of `pextrb` and `add` instructions is repeated until all 32 bytes in the current block pixel block have been processed. While it may seem somewhat counterintuitive, the use of two intermediate histograms in the main processing loop is actually faster than using a single histogram buffer. The reason for this is that a single histogram buffer creates a memory bottleneck since only one entry can be updated. Despite the fact that the dual histogram approach still extracts individual pixel values from registers `XMM0-XMM3`, it can better exploit the processor's out-of-order instruction execution mechanisms and memory caching facilities. In Chapter 21, you learn more about processor out-of-order instruction execution and memory caching.

Following completion of the main processing loop, a series of `movdqa` and `padd` instructions sum the pixel counts in the intermediate histograms to create the final histogram. Note that the histogram-summing loop adds eight unsigned doubleword entries during each iteration, which improves performance. Output 10-2 shows the results of the `SsePackedIntegerHistogram` sample program and Table 10-1 contains some timing measurements.

Output 10-2. Sample Program `SsePackedIntegerHistogram`

```
Results for SsePiHistogram()
Histograms are identical
```

```
Benchmark times saved to file __SsePackedIntegerHistogramTimed.csv
```

Table 10-1. Mean Execution Times (in Microseconds) for Histogram Functions in Sample Program `SsePackedIntegerHistogram` Using `TestImage1.bmp`

CPU	SsePiHistogramCpp (C++)	SsePiHistogram_ (x86-SSE)
Intel Core i7-4770	296	235
Intel Core i7-4600U	351	277
Intel Core i3-2310M	668	485

Packed Integer Threshold

The final x86-SSE packed integer sample program that you examine is called `SsePackedIntegerThreshold`. This sample program illustrates how to perform a common image-processing technique called thresholding using the x86-SSE instruction set. It also shows how to compute the mean intensity value of select pixels in a grayscale image. Listings 10-5, 10-6, and 10-7 show the C++ and assembly language source code for the `SsePackedIntegerThreshold` sample program.

Listing 10-5. `SsePackedIntegerThreshold.h`

```
#pragma once
#include "ImageBuffer.h"

// Image threshold data structure. This structure must agree with the
// structure that's defined in SsePackedIntegerThreshold.asm.
typedef struct
{
    UInt8* PbSrc;           // Source image pixel buffer
    UInt8* PbMask;         // Mask mask pixel buffer
    UInt32 NumPixels;      // Number of source image pixels
    UInt8 Threshold;      // Image threshold value
    UInt8 Pad[3];         // Available for future use
    UInt32 NumMaskedPixels; // Number of masked pixels
    UInt32 SumMaskedPixels; // Sum of masked pixels
    double MeanMaskedPixels; // Mean of masked pixels
} ITD;

// Functions defined in SsePackedIntegerThreshold.cpp
extern bool SsePiThresholdCpp(ITD* itd);
extern bool SsePiCalcMeanCpp(ITD* itd);

// Functions defined in SsePackedIntegerThreshold.asm
extern "C" bool SsePiThreshold_(ITD* itd);
extern "C" bool SsePiCalcMean_(ITD* itd);

// Functions defined in SsePackedIntegerThresholdTimed.cpp
extern void SsePiThresholdTimed(void);

// Miscellaneous constants
const UInt8 TEST_THRESHOLD = 96;
```

Listing 10-6. SsePackedIntegerThreshold.cpp

```

#include "stdafx.h"
#include "SsePackedIntegerThreshold.h"
#include <stddef.h>

extern "C" UInt32 NUM_PIXELS_MAX = 16777216;

bool SsePiThresholdCpp(ITD* itd)
{
    UInt8* pb_src = itd->PbSrc;
    UInt8* pb_mask = itd->PbMask;
    UInt8 threshold = itd->Threshold;
    UInt32 num_pixels = itd->NumPixels;

    // Make sure num_pixels is valid
    if ((num_pixels == 0) || (num_pixels > NUM_PIXELS_MAX))
        return false;
    if ((num_pixels & 0x1f) != 0)
        return false;

    // Make sure image buffers are properly aligned
    if (((uintptr_t)pb_src & 0xf) != 0)
        return false;
    if (((uintptr_t)pb_mask & 0xf) != 0)
        return false;

    // Threshold the image
    for (UInt32 i = 0; i < num_pixels; i++)
        *pb_mask++ = (*pb_src++ > threshold) ? 0xff : 0x00;

    return true;
}

bool SsePiCalcMeanCpp(ITD* itd)
{
    UInt8* pb_src = itd->PbSrc;
    UInt8* pb_mask = itd->PbMask;
    UInt32 num_pixels = itd->NumPixels;

    // Make sure num_pixels is valid
    if ((num_pixels == 0) || (num_pixels > NUM_PIXELS_MAX))
        return false;
    if ((num_pixels & 0x1f) != 0)
        return false;

```

```

// Make sure image buffers are properly aligned
if (((uintptr_t)pb_src & 0xf) != 0)
    return false;
if (((uintptr_t)pb_mask & 0xf) != 0)
    return false;

// Calculate mean of masked pixels
UInt32 sum_masked_pixels = 0;
UInt32 num_masked_pixels = 0;

for (UInt32 i = 0; i < num_pixels; i++)
{
    UInt8 mask_val = *pb_mask++;
    num_masked_pixels += mask_val & 1;
    sum_masked_pixels += (*pb_src++ & mask_val);
}

itd->NumMaskedPixels = num_masked_pixels;
itd->SumMaskedPixels = sum_masked_pixels;

if (num_masked_pixels > 0)
    itd->MeanMaskedPixels = (double)sum_masked_pixels /
num_masked_pixels;
else
    itd->MeanMaskedPixels = -1.0;

return true;
}

void SsePiThreshold()
{
    wchar_t* fn_src = L"..\\..\\..\\DataFiles\\TestImage2.bmp";
    wchar_t* fn_mask1 = L"__TestImage2_Mask1.bmp";
    wchar_t* fn_mask2 = L"__TestImage2_Mask2.bmp";
    ImageBuffer* im_src = new ImageBuffer(fn_src);
    ImageBuffer* im_mask1 = new ImageBuffer(*im_src, false);
    ImageBuffer* im_mask2 = new ImageBuffer(*im_src, false);
    ITD itd1, itd2;

    itd1.PbSrc = (UInt8*)im_src->GetPixelBuffer();
    itd1.PbMask = (UInt8*)im_mask1->GetPixelBuffer();
    itd1.NumPixels = im_src->GetNumPixels();
    itd1.Threshold = TEST_THRESHOLD;

    itd2.PbSrc = (UInt8*)im_src->GetPixelBuffer();
    itd2.PbMask = (UInt8*)im_mask2->GetPixelBuffer();
    itd2.NumPixels = im_src->GetNumPixels();
    itd2.Threshold = TEST_THRESHOLD;
}

```

```

bool rc1 = SsePiThresholdCpp(&itd1);
bool rc2 = SsePiThreshold_(&itd2);

if (!rc1 || !rc2)
{
    printf("Bad Threshold return code: rc1=%d, rc2=%d\n", rc1, rc2);
    return;
}

im_mask1->SaveToBitmapFile(fn_mask1);
im_mask2->SaveToBitmapFile(fn_mask2);

// Calculate mean of masked pixels
rc1 = SsePiCalcMeanCpp(&itd1);
rc2 = SsePiCalcMean_(&itd2);

if (!rc1 || !rc2)
{
    printf("Bad CalcMean return code: rc1=%d, rc2=%d\n", rc1, rc2);
    return;
}

printf("Results for SsePackedIntegerThreshold\n\n");
printf("                C++          X86-SSE\n");
printf("-----\n");
printf("SumPixelsMasked: ");
printf("%12u %12u\n", itd1.SumMaskedPixels, itd2.SumMaskedPixels);
printf("NumPixelsMasked: ");
printf("%12u %12u\n", itd1.NumMaskedPixels, itd2.NumMaskedPixels);
printf("MeanPixelsMasked: ");
printf("%12.6lf %12.6lf\n", itd1.MeanMaskedPixels, itd2.MeanMaskedPixels);

delete im_src;
delete im_mask1;
delete im_mask2;
}

int _tmain(int argc, _TCHAR* argv[])
{
    try
    {
        SsePiThreshold();
        SsePiThresholdTimed();
    }
}

```

```

catch (...)
{
    printf("Unexpected exception has occurred!\n");
    printf("File: %s (_tmain)\n", __FILE__);
}
return 0;
}

```

Listing 10-7. SsePackedIntegerThreshold.asm

```

.model flat,c
extern NUM_PIXELS_MAX:dword

; Image threshold data structure (see SsePackedIntegerThreshold.h)
ITD struct
PbSrc      dword ?
PbMask     dword ?
NumPixels  dword ?
Threshold  byte ?
Pad        byte 3 dup(?)
NumMaskedPixels  dword ?
SumMaskedPixels  dword ?
MeanMaskedPixels  real8 ?
ITD ends

        .const
        align 16
PixelScale      byte 16 dup(80h)          ;uint8 to int8 scale value
CountPixelsMask byte 16 dup(01h)          ;mask to count pixels
R8_MinusOne     real8 -1.0                ;invalid mean value
        .code

; extern "C" bool SsePiThreshold_(ITD* itd);
;
; Description: The following function performs image thresholding
;              of an 8 bits-per-pixel grayscale image.
;
; Returns:     0 = invalid size or unaligned image buffer
;              1 = success
;
; Requires:    SSSE3

SsePiThreshold_ proc
    push ebp
    mov ebp,esp
    push esi
    push edi

```

```

; Load and verify the argument values in ITD structure
mov edx,[ebp+8]                ;edx = 'itd'
xor eax,eax                    ;set error return code
mov ecx,[edx+ITD.NumPixels]    ;ecx = NumPixels
test ecx,ecx
jz Done                        ;jump if num_pixels == 0
cmp ecx,[NUM_PIXELS_MAX]
ja Done                        ;jump if num_pixels too big
test ecx,0fh
jnz Done                       ;jump if num_pixels % 16 != 0
shr ecx,4                      ;ecx = number of packed pixels

mov esi,[edx+ITD.PbSrc]        ;esi = PbSrc
test esi,0fh
jnz Done                       ;jump if misaligned
mov edi,[edx+ITD.PbMask]      ;edi = PbMask
test edi,0fh
jnz Done                       ;jump if misaligned

; Initialize packed threshold
movzx eax,byte ptr [edx+ITD.Threshold] ;eax = threshold
movd xmm1,eax                 ;xmm1[7:0] = threshold
pxor xmm0,xmm0               ;mask for pshufb
pshufb xmm1,xmm0             ;xmm1 = packed threshold
movdqa xmm2,xmmword ptr [PixelScale]
psubb xmm1,xmm2              ;xmm1 = scaled threshold

; Create the mask image
@@: movdqa xmm0,[esi]          ;load next packed pixel
psubb xmm0,xmm2              ;xmm0 = scaled image pixels
pcmpgtb xmm0,xmm1            ;compare against threshold
movdqa [edi],xmm0            ;save packed threshold mask
add esi,16
add edi,16
dec ecx
jnz @B                        ;repeat until done
mov eax,1                    ;set return code

Done: pop edi
pop esi
pop ebp
ret
SsePiThreshold_endp

```

```

; extern "C" bool SsePiCalcMean_(ITD* itd);
;
; Description: The following function calculates the mean value all
;             above-threshold image pixels using the mask created by
;             the function SsePiThreshold_.
;
; Returns:    0 = invalid image size or unaligned image buffer
;            1 = success
;
; Requires:   SSSE3

SsePiCalcMean_ proc
    push ebp
    mov ebp,esp
    push ebx
    push esi
    push edi

; Load and verify the argument values in ITD structure
    mov eax,[ebp+8]           ;eax = 'itd'
    mov ecx,[eax+ITD.NumPixels] ;ecx = NumPixels
    test ecx,ecx
    jz Error                 ;jump if num_pixels == 0
    cmp ecx,[NUM_PIXELS_MAX]
    ja Error                 ;jump if num_pixels too big
    test ecx,0fh
    jnz Error                ;jump if num_pixels % 16 != 0
    shr ecx,4                ;ecx = number of packed pixels

    mov edi,[eax+ITD.PbMask] ;edi = PbMask
    test edi,0fh
    jnz Error                ;jump if PbMask not aligned
    mov esi,[eax+ITD.PbSrc]  ;esi = PbSrc
    test esi,0fh
    jnz Error                ;jump if PbSrc not aligned

; Initialize values for mean calculation
    xor edx,edx              ;edx = update counter
    pxor xmm7,xmm7          ;xmm7 = packed zero

    pxor xmm2,xmm2          ;xmm2 = sum_masked_pixels (8 words)
    pxor xmm3,xmm3          ;xmm3 = sum_masked_pixels (8 words)
    pxor xmm4,xmm4          ;xmm4 = sum_masked_pixels (4 dwords)

    pxor xmm6,xmm6          ;xmm6 = num_masked_pixels (8 bytes)
    xor ebx,ebx             ;ebx = num_masked_pixels (1 dword)

```



```

; Register usage for processing loop
; esi = PbSrc, edi = PbMask, eax = itd
; ebx = num_pixels_masked, ecx = NumPixels / 16, edx = update counter
;
; xmm0 = packed pixel, xmm1 = packed mask
; xmm3:xmm2 = sum_masked_pixels (16 words)
; xmm4 = sum_masked_pixels (4 dwords)
; xmm5 = scratch register
; xmm6 = packed num_masked_pixels
; xmm7 = packed zero

@@:    movdqa xmm0,xmmword ptr [esi]        ;load next packed pixel
        movdqa xmm1,xmmword ptr [edi]        ;load next packed mask

; Update sum_masked_pixels (word values)
        movdqa xmm5,xmmword ptr [CountPixelsMask]
        pand xmm5,xmm1
        paddb xmm6,xmm5                ;update num_masked_pixels
        pand xmm0,xmm1                ;set non-masked pixels to zero
        movdqa xmm1,xmm0
        punpcklbw xmm0,xmm7
        punpckhbw xmm1,xmm7        ;xmm1:xmm0 = masked pixels (words)
        paddw xmm2,xmm0
        paddw xmm3,xmm1                ;xmm3:xmm2 = sum_masked_pixels

; Check and see if it's necessary to update the dword sum_masked_pixels
; in xmm4 and num_masked_pixels in ebx
        inc edx
        cmp edx,255
        jb NoUpdate
        call SsePiCalcMeanUpdateSums
NoUpdate:
        add esi,16
        add edi,16
        dec ecx
        jnz @B                        ;repeat loop until done

; Main processing loop is finished. If necessary, perform final update
; of sum_masked_pixels in xmm4 & num_masked_pixels in ebx.
        test edx,edx
        jz @F
        call SsePiCalcMeanUpdateSums

; Compute and save final sum_masked_pixels & num_masked_pixels
@@:    phaddq xmm4,xmm7
        phaddq xmm4,xmm7
        movd  edx,xmm4                ;edx = final sum_mask_pixels
        mov  [eax+ITD.SumMaskedPixels],edx ;save final sum_masked_pixels
        mov  [eax+ITD.NumMaskedPixels],ebx ;save final num_masked_pixels

```

```

; Compute mean of masked pixels
    test ebx,ebx                ;is num_mask_pixels zero?
    jz NoMean                  ;if yes, skip calc of mean
    cvtsi2sd xmm0,edx          ;xmm0 = sum_masked_pixels
    cvtsi2sd xmm1,ebx          ;xmm1 = num_masked_pixels
    divsd xmm0,xmm1           ;xmm0 = mean_masked_pixels
    jmp @F
NoMean: movsd xmm0,[R8_MinusOne] ;use -1.0 for no mean
@@:     movsd [eax+ITD.MeanMaskedPixels],xmm0 ;save mean
        mov eax,1                ;set return code

Done:   pop edi
        pop esi
        pop ebx
        pop ebp
        ret

Error:  xor eax,eax            ;set error return code
        jmp Done

SsePiCalcMean_ endp

; void SsePiCalcMeanUpdateSums
;
; Description: The following function updates sum_masked_pixels in xmm4
;              and num_masked_pixels in ebx. It also resets any
;              necessary intermediate values in order to prevent an
;              overflow condition.
;
; Register contents:
;   xmm3:xmm2 = packed word sum_masked_pixels
;   xmm4 = packed dword sum_masked_pixels
;   xmm6 = packed num_masked_pixels
;   xmm7 = packed zero
;   ebx = num_masked_pixels
;
; Temp registers:
;   xmm0, xmm1, xmm5, edx

SsePiCalcMeanUpdateSums proc private

; Promote packed word sum_masked_pixels to dword
    movdqa xmm0,xmm2
    movdqa xmm1,xmm3
    punpcklwd xmm0,xmm7
    punpcklwd xmm1,xmm7
    punpckhwd xmm2,xmm7
    punpckhwd xmm3,xmm7

```

```

; Update packed dword sums in sum_masked_pixels
    padd  xmm0,xmm1
    padd  xmm2,xmm3
    padd  xmm4,xmm0
    padd  xmm4,xmm2                ;xmm4 = packed sum_masked_pixels

; Sum num_masked_pixel counts (bytes) in xmm6, then add to total in ebx.
    movdqa xmm5,xmm6
    punpcklbw xmm5,xmm7
    punpckhbw xmm6,xmm7          ;xmm6:xmm5 = packed num_masked_pixels
    padd  xmm6,xmm5              ;xmm6 = packed num_masked_pixels
    phaddw xmm6,xmm7
    phaddw xmm6,xmm7
    phaddw xmm6,xmm7            ;xmm6[15:0] = final word sum
    movd  edx,xmm6
    add  ebx,edx                 ;ebx = num_masked_pixels

; Reset intermediate values
    xor  edx,edx
    pxor xmm2,xmm2
    pxor xmm3,xmm3
    pxor xmm6,xmm6
    ret
SsePiCalcMeanUpdateSums endp
end

```

Image thresholding is an image-processing technique that creates a binary image from a grayscale one. This binary (or mask) image signifies which pixels in the original image are greater than a predetermined (or algorithmically derived) intensity threshold value. Figure 10-3 illustrates a thresholding example. Mask images are often employed to perform additional calculations using the original grayscale image. For example, a typical use of the mask image that's shown in Figure 10-3 is to compute the mean intensity value of all above-threshold pixels in the original grayscale image. The application of a mask image simplifies calculating the mean since it facilitates the use of simple Boolean expressions to exclude unwanted pixels from the computations. The sample program in this section demonstrates these methods.

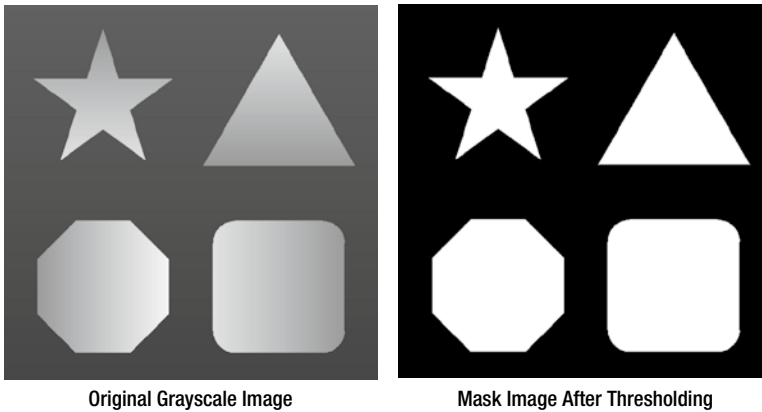

Figure 10-3. Sample grayscale image and mask image

The algorithm used by the `SsePackedIntegerThreshold` sample program consists of two phases. Phase 1 constructs that mask image that's shown in Figure 10-3. Phase 2 computes the mean intensity value of all pixels whose corresponding mask image pixel is white. The file `SsePackedIntegerThreshold.h` (see Listing 10-5) defines a structure named `ITD` that is used to maintain data required by the algorithm. Note this structure contains two pixel count elements: `NumPixels` and `NumMaskedPixels`. The former variable is the total number of image pixels while the latter value is used to maintain a count of grayscale image pixels greater than the structure element `Threshold`.

The C++ file `SsePackedIntegerThreshold.cpp` (see Listing 10-6) contains separate thresholding and mean calculating functions. The function `SsePiThresholdCpp` constructs the mask image by comparing each pixel in the grayscale image to the threshold value that's specified by `itd->Threshold`. If a grayscale image pixel is greater than this value, its corresponding pixel in the mask image is set to `0xff`; otherwise, the mask image pixel is set to `0x00`. The function `SsePiCalcMeanCpp` uses this mask image to calculate the mean intensity value of all grayscale image pixels greater than the threshold value. Note that the `for` loop of this function computes `num_mask_pixels` and `sum_mask_pixels` using simple Boolean expressions instead of logical compare statements. The latter approach is usually faster and, as you'll learn shortly, easy to implement using SIMD arithmetic.

Listing 10-7 shows the assembly language versions of the thresholding and mean calculating functions. Following its prolog, the function `SsePiThreshold_` performs validity checks of `ITD.NumPixels`, `ITD.PbSrc`, and `ITD.PbMask`. A `movzx eax,byte ptr [edx+ITD.Threshold]` instruction copies the specified threshold value into register `EAX`. After a `movd xmm1,eax` instruction, a packed threshold value is created using a `pshufb` (Packed Shuffle Bytes) instruction. The `pshufb` instruction uses the low-order four bits of each byte in the source operand as an index to permute the bytes in the destination operand (a zero is copied if the high-order bit is set in a source operand byte). This process is illustrated in Figure 10-4. In the current program, the `pshufb xmm1,xmm0` instruction copies the value in `XMM1[7:0]` to each byte element in `XMM1` since `XMM0` contains all zeros. The packed threshold value is then scaled for use by the main processing loop.

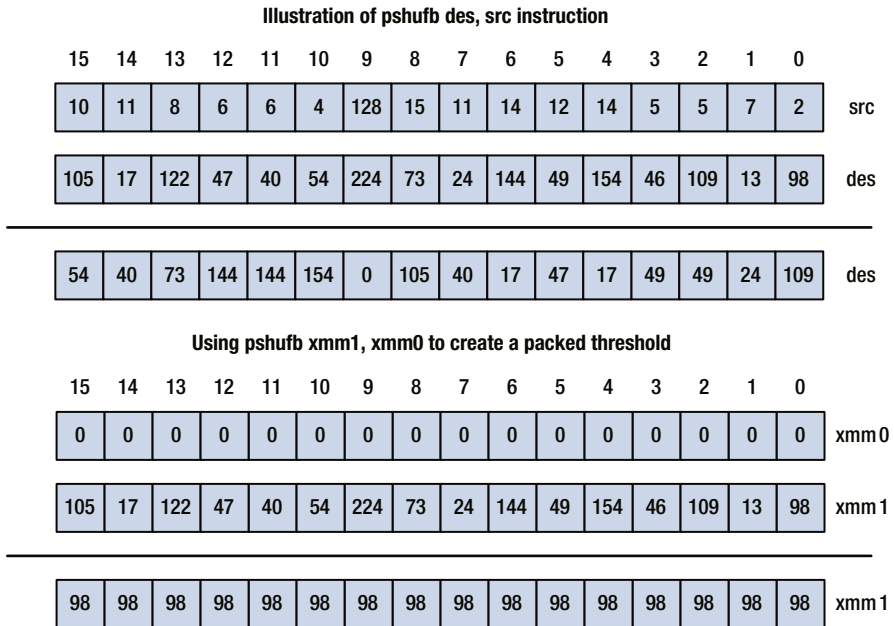

Figure 10-4. Illustration of the pshufb instruction

The main processing loop of function `SsePiThreshold_` uses the `pcmpgtb` (Compare Packed Signed Integers for Greater Than) instruction to create the mask image. This instruction performs pairwise compares of the bytes in the destination and source operands and sets each destination operand byte to `0xff` if it's greater than its corresponding source operand byte; otherwise, a value of `0x00` is used as shown in Figure 10-5. It is important to recognize that the `pcmpgtb` instruction performs its compares using signed integer arithmetic. This means that the pixels values in the grayscale image, which are unsigned byte values, must be re-scaled in order to be compatible with the `pcmpgtb` instruction. The `psubb xmm0, xmm2` instruction remaps the grayscale image pixels values in XMM0 from `[0, 255]` to `[-128, 127]`. Following execution of the `pcmpgtb` instruction, a `movdqa` instruction saves the result to the mask image buffer.

Illustration of `pcmpgtb des, src` Instruction

12	-10	-9	126	9	-7	83	-53	112	41	-21	-72	15	-9	-7	115	src
60	-89	22	-45	45	-55	114	-37	112	14	96	-72	46	9	13	98	des

ffh	00h	ffh	00h	ffh	00h	ffh	ffh	00h	00h	ffh	00h	ffh	ffh	ffh	00h	des
-----	-----	-----	-----	-----	-----	-----	-----	-----	-----	-----	-----	-----	-----	-----	-----	-----

Figure 10-5. Illustration of the `pcmpgtb` instruction

Like its C++ counterpart, the assembly language function `SsePiCalcMean_` computes the mean intensity value of all above-threshold pixels in the grayscale image. In order to compute the required pixel sum, the main processing loop manipulates two intermediate packed pixel sums using both unsigned words and unsigned doublewords. This minimizes the number packed byte to word and word to doubleword size promotions that must be performed. During each iteration, all above-threshold grayscale pixel values in `XMM0` are promoted to words and added to the packed word sums in `XMM3:XMM2`. The main processing loop also updates the count of above-threshold pixels that's maintained in `XMM6`. Figure 10-6 illustrates execution of the code block that performs these calculations. Note that the method employed in Figure 10-6 is essentially a SIMD implementation of the technique used in the for loop of the C++ function `SsePiCalcMeanCpp`.

Grayscale Image Pixel Values																
108	112	42	38	41	44	45	187	192	41	199	200	220	65	67	233	xmm0
Mask Image Pixel Values																
ffh	ffh	00h	00h	00h	00h	00h	ffh	ffh	00h	ffh	ffh	ffh	00h	00h	ffh	xmm1
CountPixelsMask																
01h	01h	01h	01h	01h	01h	01h	01h	01h	01h	01h	01h	01h	01h	01h	01h	xmm5
num_masked_pixels																
10	15	14	33	7	29	83	50	110	40	30	21	19	40	25	120	xmm6
sum_masked_pixels (low words)																
500	150	5000	1250	1200	670	2500	2200									xmm2
sum_masked_pixels (high words)																
1500	4000	1900	750	800	3250	5100	3690									xmm3
pand xmm5, xmm1																
01h	01h	00h	00h	00h	00h	00h	01h	01h	00h	01h	01h	01h	00h	00h	01h	xmm5
paddb xmm6, xmm5																
11	16	14	33	7	29	83	51	111	40	31	22	20	40	25	121	xmm6
pand xmm0, xmm1																
108	112	0	0	0	0	0	187	192	0	199	200	220	0	0	233	xmm0
movdqa xmm1, xmm0																
108	112	0	0	0	0	0	187	192	0	199	200	220	0	0	233	xmm1
punpcklbw xmm0, xmm7																
192	0	199	200	220	0	0	233									xmm0
punpckhbw xmm1, xmm7																
108	112	0	0	0	0	0	187									xmm1
paddw xmm2, xmm0																
692	150	5199	1450	1420	670	2500	2433									xmm2
paddw xmm3, xmm1																
1608	4112	1900	750	800	3250	5100	3877									xmm3

Note: xmm7 contains all zeros.

Figure 10-6. Calculation of the pixel sums and pixel counts

After every 255 iterations, the packed word pixel sums in XMM3:XMM2 are promoted to packed doublewords and added to the packed doubleword pixel sums in XMM4. The packed byte pixel counts in XMM6 are also summed and added to EBX, which contains the variable `num_masked_pixels` (the 255 iteration limit prevents an arithmetic overflow of the packed byte pixel counts in XMM6). These computations are performed in a private function named `SsePiCalcMeanUpdateSums`. Execution of the processing loop continues until all image pixels have been evaluated. Following completion of the processing loop, the four doubleword pixel intensity sums in XMM4 are reduced to the final value `sum_masked_pixels` using a couple of `phadd` instructions. The function then uses two `cvtsi2sd` instructions to convert EDX (`sum_masked_pixels`) and EBX (`num_mask_pixels`) to double-precision floating-point; it then calculates `ITD.MeanMaskedPixels` using a `divsd` instruction. Output 10-3 shows the results of the `SsePackedIntegerThreshold` sample program. Timing measurements are shown in Table 10-2.

Output 10-3. Sample Program `SsePackedIntegerThreshold`

Results for `SsePackedIntegerThreshold`

	C++	X86-SSE
SumPixelsMasked:	23813043	23813043
NumPixelsMasked:	138220	138220
MeanPixelsMasked:	172.283628	172.283628

Benchmark times saved to file `__SsePackedImageThresholdTimed.csv`

Table 10-2. Mean Execution Times (in Microseconds) for Algorithms Used in Sample Program `SsePackedImageThreshold` Using `TestImage2.bmp`

CPU	C++	X86-SSE
Intel Core i7-4770	515	49
Intel Core i7-4600U	608	60
Intel Core i3-2310M	1199	108

Summary

In this chapter, you learned how to perform fundamental arithmetic operations using the packed integer capabilities of x86-SSE. You also reviewed a couple of sample programs that illustrated accelerated implementations of common image processing algorithms. Your x86-SSE programming edification continues in the next chapter, which examines the text string processing instructions of x86-SSE.



X86-SSE Programming – Text Strings

The sample code from the previous three chapters focused on using the x86-SSE instruction set to implement numerically-oriented algorithms. In this chapter, you learn about the x86-SSE text string processing instructions. The x86-SSE text string instructions are somewhat different than other x86-SSE instructions since their execution depends on the value of an immediate control byte. The first section of this chapter explains the various control byte options and their operation paradigms. It also discusses several programming precautions that you must observe when using SIMD techniques to process text strings. In the second section, you examine a couple of sample programs that illustrate basic use of the x86-SSE text string instructions.

The x86-SSE text string instructions are available on processors that support SSE4.2, which includes the AMD FX and Intel Core processor families. You can use one of the utilities mentioned in Appendix C to determine whether the processor in your PC supports SSE4.2. In Chapter 16, you learn how to detect processor features and extensions such as SSE4.2 at run-time using the `cpuid` instruction.

Text String Fundamentals

Programming languages typically use one of two techniques to manage and process text strings. An *explicit-length* text string is a sequence of consecutive characters whose length is pre-computed and maintained along with the actual text string. Programming languages such as Pascal use this approach. An *implicit-length* text string uses a terminating end-of-string (EOS) character (usually 0) to signify the end of a text string in memory and facilitate string-processing functions such as length calculations and concatenations. This method is used by C++, as discussed in Chapter 2 (see the sample programs `CountChars` and `ConcatStrings`).

Text string processing tends to require a higher level of processor utilization than you might expect. The primary reason for this is that many text string handling functions process text strings either character-by-character or in small multi-character packets. Text string functions also are likely to make extensive use of loop constructs, which can result in less-than-optimal use of the processor's front-end instruction pipelines.

The x86-SSE text string processing instructions that you examine in this section can be used to accelerate many common string primitives, including length calculations, compare operations, and token finds. They also can be used to significantly improve the performance of string search and parsing algorithms.

X86-SSE includes four SIMD text string instructions that are capable of processing text string fragments up to 128 bits in length. These instructions, which are summarized in Table 11-1, can be used to process either explicit or implicit length text strings. Two output format options, `index` and `mask`, are available and the meaning of these options is described shortly. The processor also uses status bits in the EFLAGS register to report additional text string instruction results. Each x86-SSE text string instruction requires an 8-bit immediate control value that enables the programmer to select instruction options, including character size (8-bit or 16-bit), compare and aggregation method, and output format. Since C++ uses implicit-length strings, the explanations that follow primarily focus on the `pcmpistri` and `pcmpistrm` instructions. Execution of the explicit-length instructions `pcmpestri` and `pcpestrm` is essentially the same, except that the text string fragment lengths must be specified using registers EAX and EDX.

Table 11-1. Summary of x86-SSE Text String Instructions

Mnemonic	String Type	Output Format
<code>Pcmpestri</code>	Explicit	Index (ECX)
<code>Pcpestrm</code>	Explicit	Mask (XMM0)
<code>Pcmpistri</code>	Implicit	Index (ECX)
<code>Pcmpistrm</code>	Implicit	Mask (XMM0)

The x86-SSE text string instructions are extremely powerful and flexible. The drawback of this power and flexibility is increased instruction complexity, which some programmers initially find confusing. I'll do my best to eliminate some of this confusion by emphasizing a few common text string processing operations, which should provide a solid basis for more advanced x86-SSE text string instruction use. If you're interested in learning additional details about the x86-SSE text string instructions, you should consult the Intel and AMD reference manuals listed in Appendix C for more information.

Figure 11-1 shows an execution flow diagram for the instructions `pcmpistri` and `pcmpistrm`. The operands `strA` and `strB` are both source operands and can hold either a text string fragment or individual character values. Operand `strA` must be an XMM register, while operand `strB` can be an XMM register or a 128-bit value in memory. The operand `imm` specifies instruction control options as illustrated by the ovals in the flow diagram. Table 11-2 describes the purpose of each `imm` control option.

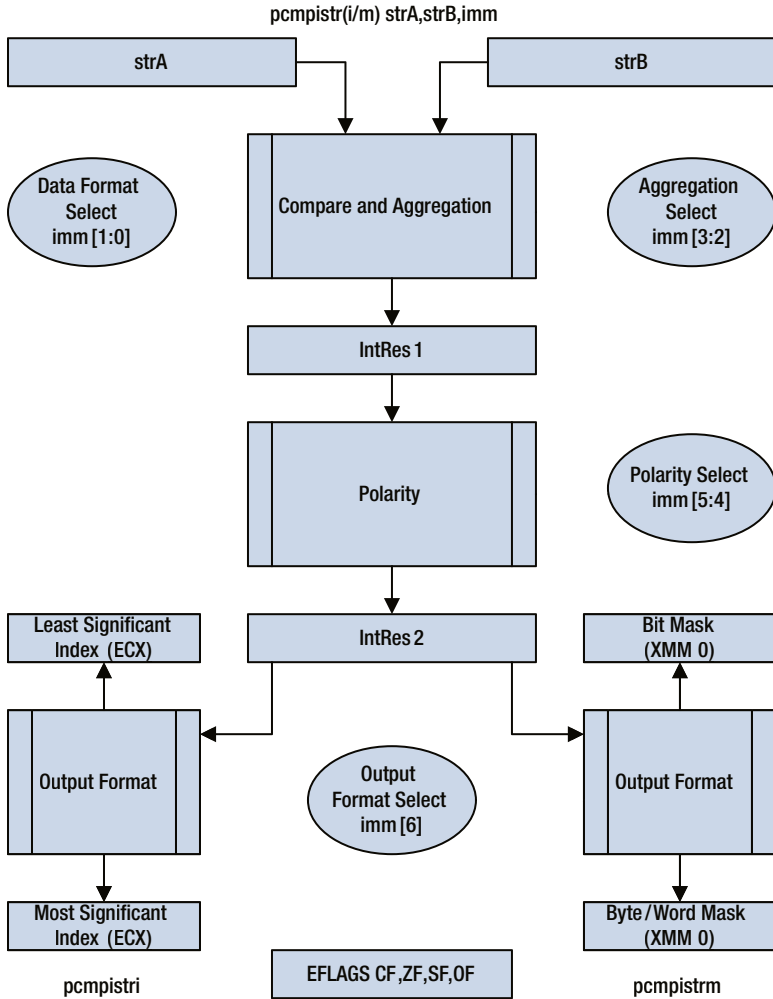

Figure 11-1. Flow diagram for the `pcmpistrX` instructions

Table 11-2. Description of Control Options for *pcmpistrX* Instructions

Control Option	Value	Description
Data Format [1:0]	00	Packed unsigned bytes
	01	Packed unsigned words
	10	Packed signed bytes
	11	Packed signed words
Aggregation [3:2]	00	Equal any (match characters)
	01	Equal range (match characters in a range)
	10	Equal each (string compare)
	11	Equal ordered (substring search)
Polarity [5:4]	00	Positive ($\text{IntRes2}[i] = \text{IntRes1}[i]$)
	01	Negative ($\text{IntRes2}[i] = \sim\text{IntRes1}[i]$)
	10	Masked positive ($\text{IntRes2}[i] = \text{IntRes1}[i]$)
	11	Masked negative ($\text{IntRes2}[i] = \text{IntRes1}[i]$ if <i>strB</i> [<i>i</i>] is invalid; otherwise = $\text{IntRes2}[i] = \sim\text{IntRes1}[i]$)
Output Format [6]	0	<i>pcmpistri</i> - ECX = index of least significant set bit in <i>IntRes2</i>
	1	<i>pcmpistri</i> - ECX = index of most significant bit set in <i>IntRes2</i>
	0	<i>pcmpistrm</i> - <i>IntRes2</i> saved as a bit mask in low-order bits of XMM0 (high-order bits are zeroed)
	1	<i>pcmpistrm</i> - <i>IntRes2</i> saved as a byte/word mask in XMM0

In order to better understand the *pcmpistrX* flow diagram and the meaning of each control option, you need to take a look at a few simple examples. Suppose you are given a text string fragment and want to create a mask to indicate the positions of the uppercase characters within the string. For example, each 1 in the mask 1000110000010010b signifies an uppercase character in the corresponding position of the text string "Ab1cDE23f4gHi5J6". You could create a C++ function to create such a mask, which would require a scanning loop and testing of each character to see if its value lies in a range between A and Z, inclusively. Another (perhaps better) option is to use the *pcmpistrm* instruction to construct the mask, as illustrated in Figure 11-2. In this example, the desired character range and text string fragment are loaded into registers XMM1 and XMM2, respectively. The immediate control value 00000100b specifies that execution of *pcmpistrm* should be performed using the options described in Table 11-3.

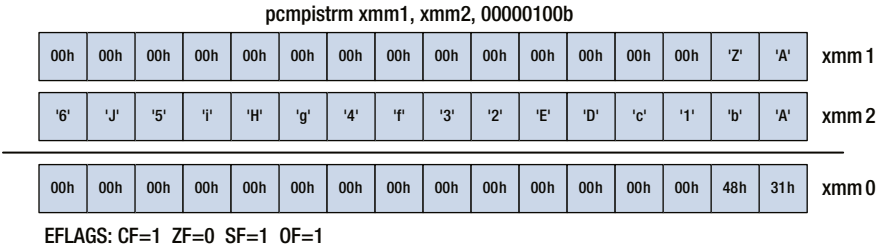

Figure 11-2. Using `pcmpistrm` to create a bit mask of uppercase characters

Table 11-3. Control Functions for `pcmpistrm xmm1, xmm2, 00000100b`

Bit Field	Value	Control Function
7	0	Reserved; must always be zero
6	0	Do not expand IntRes2 mask to bytes
5	0	Not used since IntRes1 is not negated
4	0	Do not negate IntRes1
3:2	01	Use equal range compare and aggregation
1:0	00	Source data is formatted as packed unsigned bytes

In Figure 11-2, the low-order bytes of XMM1 contain the lower and upper limits of the desired character range, while XMM2 contains the text string fragment. Note that the text string fragment in XMM2 is arranged using little-endian ordering, which automatically happens when a text string fragment is loaded using the `movdqa` or `movdq` instruction. Most of the computations performed by `pcmpistrm` occur in the box that's labeled "Compare and Aggregation" in Figure 11-1. The specific operation that the processor performs here varies depending on the selected compare and aggregation method and is explained further in a later example. The output of the compare and aggregation operation, called IntRes1, contains a bit mask of the uppercase characters in XMM2. The control value specifies that the intermediate result IntRes1 should not be inverted, which means that IntRes2 is assigned the same value as IntRes1. The control value also specifies that the 16-bit mask should not be expanded to bytes. The final mask value is saved in the low-order bytes of XMM0 and matches the little-endian ordering of the text string fragment in XMM2.

Figure 11-3 shows several additional examples of `pcmpistrm` instruction execution. The first example is similar to the example in Figure 11-2 except that the output format bit 6 is set, which means that the mask value is expanded to bytes. Expansion of the mask value to bytes is useful for further processing of the string fragment using simple Boolean expressions. The second example illustrates use of the `pcmpistrm` instruction with multiple character ranges. In this example, XMM1 contains two range pairs: one for uppercase letters and one for lowercase letters. The last example in Figure 11-3 shows a `pcmpistrm` instruction using a text string fragment that includes an embedded EOS character.

The `pcmpistri` instruction can be used to determine the index of a character or characters in a text string fragment. One use of this instruction is to find the index of an EOS character in a text string fragment, as illustrated in Figure 11-5. In the top example, the text string fragment does not contain an EOS character. In this case, execution of the `pcmpistri` instruction clears `EFLAGS.ZF` to indicate that the text string fragment does not contain an EOS character. It also loads the number of characters tested into register `ECX`, which happens to be an invalid index. In the bottom example, `EFLAGS.ZF` is set to indicate the presence of an EOS character and register `ECX` contains the corresponding index. In both the top and bottom examples, the control option value specifies a compare and aggregation method of “equal any” and inversion of the intermediate result `IntRes1`.

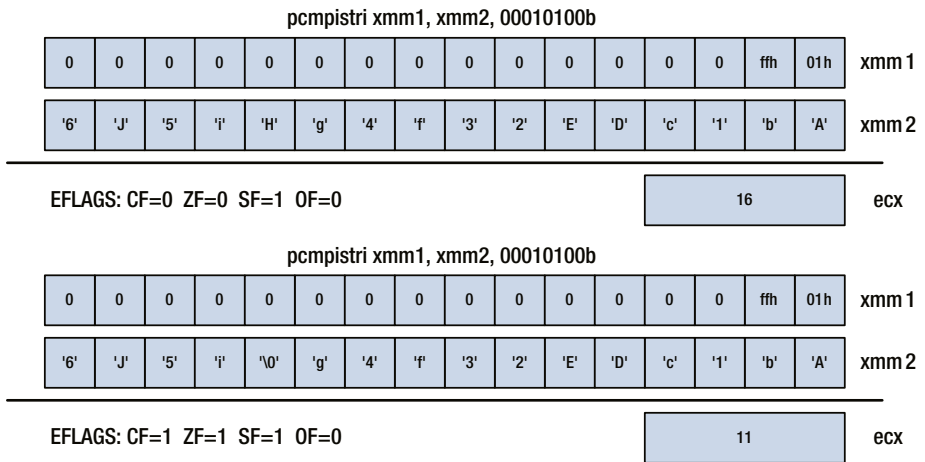

Figure 11-5. Using `pcmpistri` to find an EOS character in a string fragment

Figure 11-6 contains a more detailed example of `pcmpistri` instruction execution. Internally, the processor uses the compare and aggregation type to select a compare method and uses this method to compare all character pairs in the specified operands. In the current example, the selected aggregation type is “equal range” and Table 11-4 shows the specific compare operations. Logically, the processor is composing an 8x8 matrix of character-pair compare results and uses this matrix to compute `IntRes1` (a 16x16 matrix would be composed for byte-wide characters). Compare results for character positions including and after the EOS terminator are forced to 0. Following construction of the compare matrix, the processor computes `IntRes1` using the algorithm shown in Listing 11-1. This algorithm also varies depending on the selected compare and aggregation method. The value `IntRes2` is determined by inverting `IntRes1` as specified by the polarity field of the control value. The index of the EOS character corresponds to the index of the lowest 1 bit in `IntRes2`.

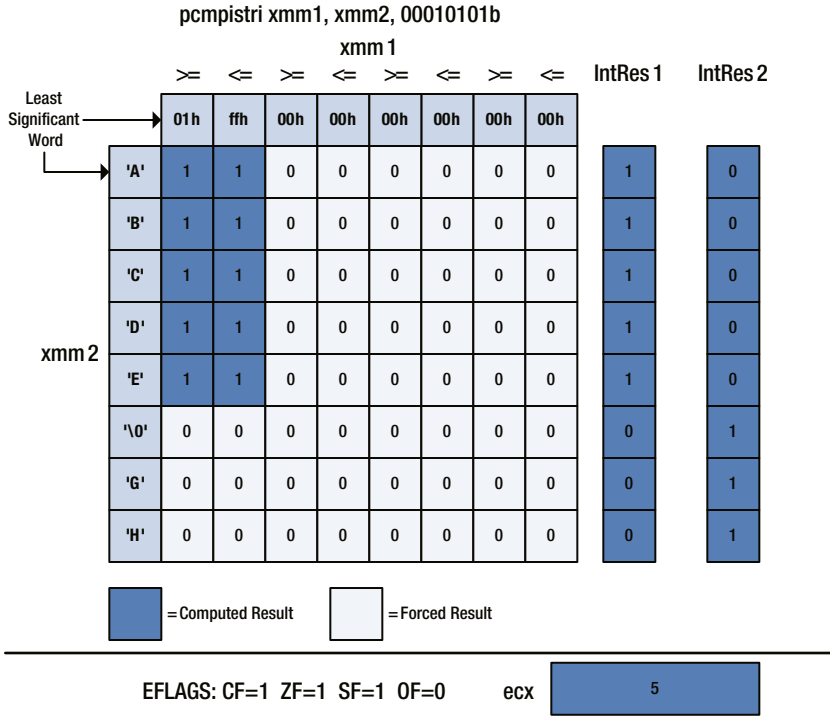

Figure 11-6. Detailed illustration of the `pcmpistri` instruction

Table 11-4. Compare Operations for the `pcmpistri` Truth Table

XMM1 Index	CmpRes
j is even	<code>CmpRes[i, j] = (xmm2[i] >= xmm1[j]) ? 1 : 0;</code>
j is odd	<code>CmpRes[i, j] = (xmm2[i] <= xmm1[j]) ? 1 : 0;</code>

Listing 11-1. Computation of IntRes1

```

for (i = 0; i < 8; i++)
{
    for (j = 0; j < 8; j += 2)
        IntRes[i] |= CmpRes[i, j] & CmpRes[i, j+1];
}
    
```

In order to use the x86-SSE text string instructions in an assembly language function, you must observe several programming precautions. Unlike multi-byte integers and floating-point values, text strings have no natural alignment boundary in memory. This means that text string fragments are usually loaded into an XMM register using the `movdqu` instruction; the `movdqa` instruction can be used only if the text string fragment is properly aligned. The processing of text strings using SIMD techniques requires the programmer to ensure that any data beyond the EOS character is not inadvertently modified. Care must also be observed when reading or writing a text string fragment in memory that's located toward the end of a page. Since x86-SSE text string reads and writes are 128-bits wide, attempting to access a short text string near the end of a page may require the processor to access the next page, as illustrated in Figure 11-7. A processor exception will occur if this page does not belong to the current process. The sample code in the next section illustrates several techniques that can be used to address the precautions outlined in this paragraph.

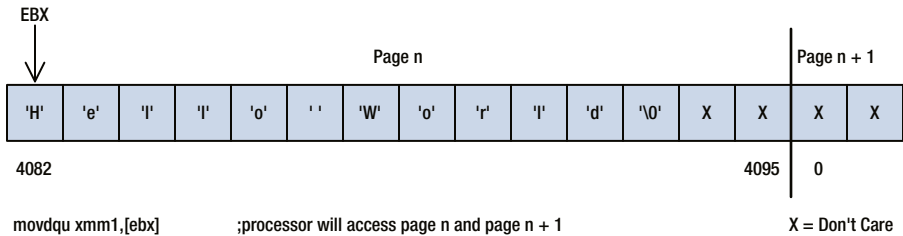

Figure 11-7. Text string load near an end-of-page boundary

Text String Programming

The discussions of the previous section focused on the key aspects of the x86-SSE text string instructions. In this section, you learn how to use the `pcmpistri` and `pcmpistrm` instructions to perform common text string processing operations. You also learn more about the programming strategies that you must employ when processing text strings using SIMD techniques.

Text String Calculate Length

The first x86-SSE text string sample program that you examine is called `SseTextStringCalcLength`. This program demonstrates how to calculate the length of a null-terminated text string using the `pcmpistri` instruction. It also shows how to handle some of the SIMD text processing caveats that were discussed earlier in this section. The C++ and assembly language source code for this program are shown in Listings 11-2 and 11-3, respectively.

Listing 11-2. SseTextStringCalcLength.cpp

```

#include "stdafx.h"
#include <malloc.h>
#include <string.h>

extern "C" int SseTextStringCalcLength_(const char* s);

const char * TestStrings[] =
{
    "0123456", // Length = 7
    "0123456789abcde", // Length = 15
    "0123456789abcdef", // Length = 16
    "0123456789abcdefg", // Length = 17
    "0123456789abcdefghijklmnopqrstu", // Length = 31
    "0123456789abcdefghijklmnopqrstuv", // Length = 32
    "0123456789abcdefghijklmnopqrstuvw", // Length = 33
    "0123456789abcdefghijklmnopqrstuvwxyz", // Length = 36
    "", // Length = 0
};

const int OffsetMin = 4096 - 40;
const int OffsetMax = 4096 + 40;
const int NumTestStrings = sizeof(TestStrings) / sizeof(char*);

void SseTextStringCalcLength(void)
{
    const int buff_size = 8192;
    const int page_size = 4096;
    char* buff = (char*)_aligned_malloc(buff_size, page_size);

    printf("\nResults for SseTextStringCalcLength()\n");

    for (int i = 0; i < NumTestStrings; i++)
    {
        bool error = false;
        const char* ts = TestStrings[i];

        printf("Test string: \"%s\"\n", ts);

        for (int offset = OffsetMin; offset <= OffsetMax; offset++)
        {
            char* s2 = buff + offset;

            memset(buff, 0x55, buff_size);
            strcpy_s(s2, buff_size - offset, ts);
        }
    }
}

```

```

int len1 = strlen(s2);
int len2 = SseTextStringCalcLength_(s2);

if ((len1 != len2) && !error)
{
    error = true;
    printf(" String length compare failed!\n");
    printf(" buff: 0x%p offset: %5d s2: 0x%p", buff, offset, s2);
    printf(" len1: %5d len2: %5d\n",len1, len2);
}

if (!error)
    printf("No errors detected\n");
}

int _tmain(int argc, _TCHAR* argv[])
{
    SseTextStringCalcLength();
    return 0;
}

```

Listing 11-3. SseTextStringCalcLength_.asm

```

.model flat,c
.code

; extern "C" int SseTextStringCalcLength_(const char* s);
;
; Description: The following function calculates the length of a
;               text string using the x86-SSE instruction pcmpistri.
;
; Returns:      Length of text string
;
; Requires      SSE4.2

SseTextStringCalcLength_ proc
    push ebp
    mov ebp,esp

; Initialize registers for string length calculation
    mov eax,[ebp+8]           ;eax = 's'
    sub eax,16               ;adjust eax for use in loop
    mov edx,0ff01h
    movd xmm1,edx           ;xmm1[15:0] = char range

```

```

; Calculate next address and test for near end-of-page condition
@@:   add eax,16           ;eax = next text block
      mov edx,eax
      and edx,0ffff      ;edx = low 12 bits of address
      cmp edx,0ff0h
      ja NearEndOfPage   ;jump if within 16 bytes of page boundary

; Test current text block for '\0' byte
      pcmpestri xmm1,[eax],14h   ;compare char range and text
      jnz @B                   ;jump if '\0' byte not found

; Found '\0' byte in current block (index in ECX)
; Calculate string length and return
      add eax,ecx               ;eax = ptr to '\0' byte
      sub eax,[ebp+8]          ;eax = final string length
      pop ebp
      ret

; Search for the '\0' terminator by examining each character
NearEndOfPage:
      mov ecx,4096             ;ecx = size of page in bytes
      sub ecx,edx              ;ecx = number of bytes to check

@@::  mov dl,[eax]              ;dl = next text string character
      or dl,dl
      jz FoundNull            ;jump if '\0' found
      inc eax                  ;eax = ptr to next char
      dec ecx
      jnz @B                   ;jump if more chars to test

; Remainder of text string can be searched using 16-byte blocks
; EAX is now aligned on a 16-byte boundary
      sub eax,16               ;adjust eax for use in loop
@@:   add eax,16                ;eax = ptr to next text block
      pcmpestri xmm1,[eax],14h   ;compare char range and text
      jnz @B                   ;jump if '\0' byte not found

; Found '\0' byte in current block (index in ECX)
      add eax,ecx              ;eax = ptr to '\0' byte

; Calculate final string length and return
FoundNull:
      sub eax,[ebp+8]          ;eax = final string length
      pop ebp
      ret
SseTextStringCalcLength_ endp
      end

```

The C++ portion of sample program `SseTextStringCalcLength` (see Listing 11-2) begins by allocating a page-aligned memory block. This memory block is used to initialize different test scenarios in order to verify that the x86-32 assembly language function `SseTextStringCalcLength_` can correctly process text strings located near the end of a page. This includes the case where the EOS terminator is located on the last byte of a page. The admittedly brute-force test code also verifies that strings located completely within a page or across a page boundary are properly handled. Each string length result returned by the function `SseTextStringCalcLength_` is compared against the length value computed by the standard C++ run-time function `strlen`. The test code displays an error message if a length discrepancy is detected.

The assembly language function `SseTextStringCalcLength_` (see Listing 11-3) starts by loading the text string pointer `s` into register `EAX`. The `sub eax,16` instruction adjusts the pointer value in `EAX` for use by the processing loop. The range values required by the `pcmpistri` instruction are then loaded into register `XMM2`. At the top of the first processing loop, an `add eax,16` instruction updates register `EAX` so that it contains the address of the next 16-byte text block in memory. Updating `EAX` at the top of the processing loop using a constant value eliminates a jump instruction and prevents a loop-carry dependency condition, which can adversely affect performance. (A loop-carry dependency occurs when execution of an instruction inside a loop is dependent on the result of previous iteration. See *Intel 64 and IA-32 Architectures Optimization Reference Manual* for more information about loop-carry dependencies.) The address value in `EAX` is then tested to determine if the next text string fragment is located near the end of a page. A conditional jump instruction is executed to avoid accessing a text block that spans a page boundary since at this point you don't know if the page belongs to the current process.

If the current text block is not located near the end of a page, a `pcmpistri` instruction is used to determine if the EOS character lies in the text string fragment. If the EOS character is found, as indicated by `EFLAGS.ZF` being set to 1, the final string length is calculated and returned to the caller. Otherwise, the processing loop is repeated. The control option value for the `pcmpistri` instruction is set for unsigned bytes, "equal range," and `IntRes1` inversion.

The section of code following the label `NearEndOfPage` individually checks each character near the end of a page to see if it's an EOS character. If an EOS character is found, the final string length is calculated and returned to the caller. If an EOS character is not found on the current page, the text string spans multiple pages and it's safe to resume searching for the EOS character using the `pcmpistri` instruction. Note that end-of-page boundary checks are no longer necessary since the pointer value in `EAX` is now aligned to a 16-byte boundary. Also note that the `movdqa` instruction can now be used since the text string pointer is properly aligned. Output 11-1 shows the results of the `SseTextStringCalcLength` sample program.

Output 11-1. Sample Program SseTextStringCalcLength

```

Results for SseTextStringCalcLength()
Test string: "0123456"
  No errors detected
Test string: "0123456789abcde"
  No errors detected
Test string: "0123456789abcdef"
  No errors detected
Test string: "0123456789abcdefg"
  No errors detected
Test string: "0123456789abcdefghijklmnopqrstu"
  No errors detected
Test string: "0123456789abcdefghijklmnopqrstuv"
  No errors detected
Test string: "0123456789abcdefghijklmnopqrstuvw"
  No errors detected
Test string: "0123456789abcdefghijklmnopqrstuvwxyz"
  No errors detected
Test string: ""
  No errors detected

```

Text String Replace Characters

The second x86-SSE text string sample program that you examine is called `SseTextStringReplaceChar`. This sample program scans a text string and replaces all occurrences of a specified character. Listings 11-4 and 11-5 show the code for `SseTextStringReplaceChar.cpp` and `SseTextStringReplaceChar.asm`, respectively.

Listing 11-4. `SseTextStringReplaceChar.cpp`

```

#include "stdafx.h"
#include <string.h>
#include <malloc.h>

extern "C" int SseTextStringReplaceChar_(char* s, char old_char, char new_char);

const char* TestStrings[] =
{
    "*Red*Green*Blue*",
    "Cyan*Magenta Yellow*Black Tan",
    "White*Pink Brown Purple*Gray Orange*",
    "Beige Silver Indigo Fuchsia Maroon",
    "*****",
    "*****+*****+*****+*****+*****",
    ""
};

```

```

const char OldChar = '*';
const char NewChar = '#';
const int OffsetMin = 4096 - 40;
const int OffsetMax = 4096 + 40;
const int NumTestStrings = sizeof(TestStrings) / sizeof(char*);
const unsigned int CheckNum = 0x12345678;

int SseTextStringReplaceCharCpp(char* s, char old_char, char new_char)
{
    char c;
    int n = 0;

    while ((c = *s) != '\0')
    {
        if (c == OldChar)
        {
            *s = NewChar;
            n++;
        }

        s++;
    }

    return n;
}

void SseTextStringReplaceChar(void)
{
    const int buff_size = 8192;
    const int page_size = 4096;
    char* buff1 = (char*)_aligned_malloc(buff_size, page_size);
    char* buff2 = (char*)_aligned_malloc(buff_size, page_size);

    printf("\nResults for SseTextStringReplaceChars()\n");
    printf("OldChar = '%c'NewChar = '%c'\n", OldChar, NewChar);

    for (int i = 0; i < NumTestStrings; i++)
    {
        const char* s = TestStrings[i];
        int s_len = strlen(s);

        for (int offset = OffsetMin; offset <= OffsetMax; offset++)
        {
            bool print = (offset == OffsetMin) ? true : false;
            char* s1 = buff1 + offset;
            char* s2 = buff2 + offset;
            int size = buff_size - offset;
            int n1 = -1, n2 = -1;

```

```

    strcpy_s(s1, size, s);
    *(s1 + s_len + 1) = OldChar;
    *((unsigned int*)(s1 + s_len + 2)) = CheckNum;

    strcpy_s(s2, size, s);
    *(s2 + s_len + 1) = OldChar;
    *((unsigned int*)(s2 + s_len + 2)) = CheckNum;

    if (print)
        printf("\ns1 before replace: \"%s\"\n", s1);
    n1 = SseTextStringReplaceCharCpp(s1, OldChar, NewChar);
    if (print)
        printf("s1 after replace: \"%s\"\n", s1);

    if (print)
        printf("\ns2 before replace: \"%s\"\n", s2);
    n2 = SseTextStringReplaceChar_(s2, OldChar, NewChar);
    if (print)
        printf("s2 after replace: \"%s\"\n", s2);

    if (strcmp(s1, s1) != 0)
        printf("Error - string compare failed\n");
    if (n1 != n2)
        printf("Error - character count compare failed\n");

    if (*(s1 + s_len + 1) != OldChar)
        printf("Error - buff1 OldChar overwrite\n");
    if (*(s2 + s_len + 1) != OldChar)
        printf("Error - buff2 OldChar overwrite\n");

    if (*((unsigned int*)(s1 + s_len + 2)) != CheckNum)
        printf("Error - buff1 CheckNum overwrite\n");
    if (*((unsigned int*)(s2 + s_len + 2)) != CheckNum)
        printf("Error - buff2 CheckNum overwrite\n");
}
}

_aligned_free(buff1);
_aligned_free(buff2);
}

int _tmain(int argc, _TCHAR* argv[])
{
    SseTextStringReplaceChar();
    return 0;
}

```

Listing 11-5. SseTextStringReplaceChar_asm

```

        .model flat,c
        .const
        align 16
PxorNotMask db 16 dup(0ffh)                ;pxor logical not mask
        .code

; extern "C" int SseTextStringReplaceChar_(char* s, char old_char, char new_char);
;
; Description: The following function replaces all instances of old_char
;              with new_char in the provided text string.
;
; Requires     SSE4.2 and POPCNT feature flag.

SseTextStringReplaceChar_ proc
    push ebp
    mov ebp,esp
    push ebx
    push esi
    push edi

; Initialize
    mov eax,[ebp+8]                        ;eax = 's'
    sub eax,16                             ;adjust eax for loop below
    xor edi,edi                            ;edi = num replaced chars

; Build packed old_char and new_char
    movzx ecx,byte ptr [ebp+12]
    movd xmm1,ecx                          ;xmm1[7:0] = old_char
    movzx ecx,byte ptr [ebp+16]            ;ecx = new char
    movd xmm6,ecx
    pxor xmm5,xmm5
    pshufb xmm6,xmm5                       ;xmm6 = packed new_char
    movdqa xmm7,xmmword ptr [PxorNotMask] ;xmm7 = pxor not mask

; Calculate next string address and test for near end-of-page condition
Loop1:  add eax,16                          ;eax = next text block
        mov edx,eax
        and edx,0ffffh                    ;edx = low 12 bits of address
        cmp edx,0fff0h
        ja NearEndOfPage                  ;jump if within 16 bytes of page boundary

```

```

; Compare current text block to find characters
    movdqu xmm2,[eax]           ;load next text block
    pcmptestrm xmm1,xmm2,40h    ;test for old_char match
    setz cl                     ;set if '\0' found
    jc FoundMatch1             ;jump if matches found
    jz Done                    ;jump if '\0' found
    jmp Loop1                  ;jump if no matches found

; Character matches found (xmm0 = match mask)
; Update character match count in EDI
FoundMatch1:
    pmovmskb edx,xmm0          ;edx = match mask
    popcnt edx,edx             ;count the number of matches
    add edi,edx                ;edi = total match count

; Replace all old_char with new_char
    movdqa xmm3,xmm0          ;xmm3 = match mask
    pxor xmm0,xmm7             ;remove old_chars
    pand xmm0,xmm2
    pand xmm3,xmm6
    por xmm0,xmm3              ;insert new_chars
    movdqu [eax],xmm0         ;save updated string
    or cl,cl                   ;does current block contain '\0'?
    jnz Done                   ;jump if yes
    jmp Loop1                  ;continue processing text string

; Replace old_char with new_char near end of page
NearEndOfPage:
    mov ecx,4096               ;size of page in bytes
    sub ecx,edx                ;ecx = number of bytes to check
    mov dl,[ebp+12]           ;dl = old_char
    mov dh,[ebp+16]           ;dh = new_char

Loop2:  mov bl,[eax]           ;load next input string character
        or bl,bl
        jz Done                ;jump if '\0' found
        cmp dl,bl
        jne @F                 ;jump if no match
        mov [eax],dh           ;replace old_char with new_char
        inc edi                ;update num replaced characters
@@:    inc eax                  ;eax = ptr to next char
        dec ecx
        jnz Loop2              ;repeat until end of page
        sub eax,16             ;adjust eax to eliminate jump

```

```

; Process remainder of text string; note that movdqa can now be used
Loop3:  add  eax,16                                ;eax = next text block
        movdqa xmm2,[eax]                       ;load next text block
        pcmpestriq xmm1,xmm2,40h               ;test for old_char match
        setz  cl                                ;set if '\0' found
        jc   FoundMatch3                      ;jump if matches found
        jz   Done                             ;jump if '\0' found
        jmp  Loop3                             ;jump if no matches found

FoundMatch3:
        pmovmskb edx,xmm0                      ;edx = match mask
        popcnt  edx,edx                        ;count the number of matches
        add  edi,edx                           ;edi = total match count

; Replace all old_char with new_char
        movdqa xmm3,xmm0                       ;xmm3 = match mask
        pxor  xmm0,xmm7                       ;mask out all old_chars
        pand  xmm0,xmm2
        pand  xmm3,xmm6
        por   xmm0,xmm3                       ;insert new_chars
        movdqa [eax],xmm0                     ;save updated string
        or   cl,cl                             ;does current block contain '\0'?
        jnz  Done                             ;jump if yes
        jmp  Loop3                             ;continue processing text string

Done:   mov  eax,edi                            ;eax = num replaced characters
        pop  edi
        pop  esi
        pop  ebx
        pop  ebp
        ret

SseTextStringReplaceChar_ endp
end

```

Near the top of file `SseTextStringReplaceChar.cpp` (see Listing 11-4) is a function named `SseTextStringReplaceCharCpp`, which implements a C++ version of the replace character algorithm. The function `SseTextStringReplaceChar` initializes a variety of test cases in order to confirm operation of both replace character functions. Since the assembly language version of the replace character algorithm will be updating the text string using SIMD techniques, the character to be replaced and a check number are written to the memory buffer immediately after the EOS character. This signature pattern is used to determine if any bytes following the EOS character are erroneously modified. Similar to the previous sample program, the function `SseTextStringReplaceChar` also copies each test string to multiple locations in the memory buffer in order to verify proper handling of end-of-page and page-spanning text strings.

The assembly language function `SseTextStringReplaceChar_` (see Listing 11-5) starts by initializing `EAX` as a pointer to the text string. Register `EDI` is then set to zero and is used to maintain a count of replaced characters. The argument values `old_char` and `new_char` are loaded into registers `XMM1` and `XMM6`, respectively. Note that `old_char` occupies only the low-order byte of `XMM1` (the other bytes of `XMM1` are zero), while `new_char` resides in each byte position of `XMM6`. A `pshufb xmm6, xmm5` instruction (`XMM5` contains all zeros) creates a packed version of `new_char` (i.e., all byte positions in `XMM5` equal `new_char`) and this value will be used during replace operations. `XMM7` is then loaded with a character inversion mask value.

Near the top of `Loop1`, the string pointer in `EAX` is tested to determine if the next text string fragment crosses a page boundary. If the current text string fragment is not located near the end of a page, it is loaded into `XMM2` using a `movdqu` instruction. A `pcmpistrm xmm1, xmm2, 40h` instruction tests the current text string fragment for any occurrences of `old_char`. The control value for this instruction specifies unsigned packed bytes, “equal any,” and byte mask. `EFLAGS.CF` is set if a character match is found while `EFLAGS.ZF` is set if the current text string fragment contains an EOS character. It is important to recognize that these are not mutually exclusive conditions, which is why a `setz cl` instruction is used to save the status of `EFLAGS.ZF` for later use. Following execution of the `pcmpistrm` instruction, `XMM0` contains a mask of matched characters (`0x00` = no match, `0xff` = match).

The section of code following the label `FoundMatch1` updates the matching character count and performs a packed character replacement. The instruction `pmovmskb edx, xmm0` (Move Byte Mask) creates a mask using the most significant bits of each byte in `XMM0` and saves this mask to the low-order word of register `EDX` (the high-order word is zero-filled). A `popcnt edx, edx` (Return the Count of Number of Bits Set to 1) instruction counts the number of set bits in `EDX`, which equals the number of matching characters. This count value is then added to the total number of matching characters that’s maintained in register `EDI`. Figure 11-8 illustrates the technique used to replace each occurrence of `old_char` with `new_char`. Following the packed character replacement operation, program control is transferred either back to the top of `Loop1` or to the function’s epilog if the current text string fragment contains an EOS terminator byte.

Initial XMM register values

ffh	00h	00h	00h	00h	ffh	00h	00h	00h	00h	00h	ffh	00h	00h	00h	ffh	xmm0 xmm3
'*'	'e'	'u'	'l'	'B'	'*'	'n'	'e'	'e'	'r'	'G'	'*'	'd'	'e'	'R'	'*'	xmm2
'#'	'#'	'#'	'#'	'#'	'#'	'#'	'#'	'#'	'#'	'#'	'#'	'#'	'#'	'#'	'#'	xmm6
ffh	ffh	ffh	ffh	ffh	ffh	ffh	ffh	ffh	ffh	ffh	ffh	ffh	ffh	ffh	ffh	xmm7

pxor xmm0, xmm7

00h	ffh	ffh	ffh	ffh	00h	ffh	ffh	ffh	ffh	ffh	00h	ffh	ffh	ffh	00h	xmm0
-----	-----	-----	-----	-----	-----	-----	-----	-----	-----	-----	-----	-----	-----	-----	-----	------

pand xmm0, xmm2

00h	'e'	'u'	'l'	'B'	00h	'n'	'e'	'e'	'r'	'G'	00h	'd'	'e'	'R'	00h	xmm0
-----	-----	-----	-----	-----	-----	-----	-----	-----	-----	-----	-----	-----	-----	-----	-----	------

pand xmm3, xmm6

'#'	00h	00h	00h	00h	'#'	00h	00h	00h	00h	00h	'#'	00h	00h	00h	'#'	xmm3
-----	-----	-----	-----	-----	-----	-----	-----	-----	-----	-----	-----	-----	-----	-----	-----	------

por xmm0, xmm3

'#'	'e'	'u'	'l'	'B'	'#'	'n'	'e'	'e'	'r'	'G'	'#'	'd'	'e'	'R'	'#'	xmm0
-----	-----	-----	-----	-----	-----	-----	-----	-----	-----	-----	-----	-----	-----	-----	-----	------

Figure 11-8. Illustration of the packed character replacement technique

The label `NearEndOfPage` marks the start of a code block that performs character replacements near the end of a page. Text string characters are tested individually for a match with `old_char` and replaced with `new_char` if a match is found. This block of code also checks each character to see if it's equal to the EOS terminator. If an EOS terminator is found, execution of the replacement loop is terminated.

After processing the characters near the end of a page, the function can resume SIMD text string character match checking using the `pcmpistrm` instruction. Since the pointer in register `EAX` is now aligned on a 16-byte boundary, a `movdqa` instruction is used to load the remaining text string fragment into register `XMM2`. The processing loop following label `Loop3` uses the same method to replace matched characters, as shown in Figure 11-8. Output 11-2 shows the results of the `SseTextStringReplaceChar` sample program.

Output 11-2. Sample Program SseTextStringReplaceChar

Results for SseTextStringReplaceChars()

OldChar = '*' NewChar = '#'

s1 before replace: "*Red*Green*Blue*"

s1 after replace: "#Red#Green#Blue#"

s2 before replace: "*Red*Green*Blue*"

s2 after replace: "#Red#Green#Blue#"

s1 before replace: "Cyan*Magenta Yellow*Black Tan"

s1 after replace: "Cyan#Magenta Yellow#Black Tan"

s2 before replace: "Cyan*Magenta Yellow*Black Tan"

s2 after replace: "Cyan#Magenta Yellow#Black Tan"

s1 before replace: "White*Pink Brown Purple*Gray Orange*"

s1 after replace: "White#Pink Brown Purple#Gray Orange#"

s2 before replace: "White*Pink Brown Purple*Gray Orange*"

s2 after replace: "White#Pink Brown Purple#Gray Orange#"

s1 before replace: "Beige Silver Indigo Fuchsia Maroon"

s1 after replace: "Beige Silver Indigo Fuchsia Maroon"

s2 before replace: "Beige Silver Indigo Fuchsia Maroon"

s2 after replace: "Beige Silver Indigo Fuchsia Maroon"

s1 before replace: "*****"

s1 after replace: "#####"

s2 before replace: "*****"

s2 after replace: "#####"

s1 before replace: "*****+*****+*****+*****+*****"

s1 after replace: "#####+#####+#####+#####+#####"

s2 before replace: "*****+*****+*****+*****+*****"

s2 after replace: "#####+#####+#####+#####+#####"

s1 before replace: ""

s1 after replace: ""

s2 before replace: ""

s2 after replace: ""

Summary

In this chapter, you learned how to perform basic operations using the x86-SSE text string processing instructions. You also gained a few insights regarding the programming precautions that you must observe when you're using SIMD techniques to process text strings. Earlier in this chapter I mentioned that the x86-SSE text string instructions are extremely powerful and flexible, but somewhat confusing to use. Hopefully, I've eliminated or at least reduced some of the confusion surrounding these instructions.

The previous four chapters surveyed a significant amount of x86-SSE sample code. They included numerous sample programs (perhaps too many) and meticulous explanations to accentuate the importance of x86-SSE and its computational advantages. The title of this book incorporates the word *modern* and was chosen to encourage the use of contemporary processor extensions such as x86-SSE over legacy instructions and architectural resources whenever feasible. In the next set of chapters, you expand your knowledge of modern assembly language programming by examining the most recent SIMD extension to the x86 platform, which is called *Advanced Vector Extensions*.



Advanced Vector Extensions (AVX)

In the previous seven chapters, you learned about the SIMD processing capabilities of MMX and x86-SSE. MMX introduced elementary integer SIMD arithmetic and related operations to the x86 platform. These capabilities were extended by x86-SSE to include wider operands, additional registers, and enhanced floating-point arithmetic using scalar and packed operands. This chapter examines the x86's most recent SIMD augmentation, which is called Advanced Vector Extensions (x86-AVX).

Like its predecessor extensions, x86-AVX adds new registers, data types, and instructions to the x86 platform. It also introduces a modern three-operand assembly language instruction syntax that helps streamline assembly language programming and improve performance. Concomitant with the introduction of x86-AVX are several distinct feature extensions, including half-precision floating-point conversions, fused-multiply-add (FMA) operations, and new general-purpose register instructions.

The content in this chapter assumes that you have a basic understanding of x86-SSE and its instruction set. Similar to the approach that was used in Chapter 7 with x86-SSE, the discussions in this chapter focus on using x86-AVX in an x86-32 execution environment. In Chapters 19 and 20, you learn how to develop x86-64 programs that use the computational resources of x86-AVX.

X86-AVX Overview

The first x86-AVX extension, called AVX, was introduced in 2011 with the Sandy Bridge microarchitecture. AVX extends the packed single-precision and double-precision floating-point capabilities of x86-SSE from 128 bits to 256 bits. It also supports a new three-operand instruction syntax using non-destructive source operands that simplifies assembly language programming considerably. Programmers can use this new instruction syntax with packed 128-bit integer, packed 128-bit floating-point, and packed 256-bit floating-point operands. The new instruction syntax can also be used to perform scalar single-precision and double-precision floating-point arithmetic. In 2012 Intel introduced an updated version of the Sandy Bridge microarchitecture called Ivy Bridge, which added instructions that perform half-precision floating-point conversions. You learn more about half-precision floating-point later in this chapter.

In 2013 Intel launched a new microarchitecture called Haswell. Processors based on this microarchitecture include AVX2, which extends the packed integer capabilities of AVX from 128 bits to 256 bits. It also includes enhanced data broadcast, blend, and permute instructions, and introduces a new vector-index addressing mode that facilitates memory loads (or gathers) of data elements from non-contiguous locations. All Haswell-based processors incorporate several AVX2-associated technologies, including FMA, enhanced bit manipulation, and flagless rotate and shift instructions.

In July of 2013, Intel announced AVX-512, which will extend the SIMD capabilities of AVX and AVX2 from 256 bits to 512 bits in future processors. Table 12-1 summarizes current and planned x86-AVX technologies. This table uses the acronyms SPFP and DPFP to signify single-precision floating-point and double-precision floating-point, respectively.

Table 12-1. Summary of x86-AVX Technologies

Release	Supported Types	Key Features and Enhancements
AVX	Packed 128-bit integer Packed 128-bit SPFP Packed 128-bit DPFP Packed 256-bit SPFP Packed 256-bit DPFP Scalar SPFP, DPFP	SIMD operations using supported data types and three-operand instruction syntax Conditional packed data loads and stores Packed floating-point broadcast and permute New floating-point compare predicates Half-precision floating-point conversions
AVX2	Packed 256-bit integer	SIMD operations using packed 256-bit integers Data gather instructions Enhanced broadcast and permute instructions FMA instructions Enhanced bit manipulation instructions Flagless rotate and shift instructions
AVX-512	Packed 512-bit integer Packed 512-bit SPFP Packed 512-bit DPFP	SIMD operations using packed 512-bit operands Conditional packed data-element operations Instruction-level rounding overrides Data scatter instructions

The Sandy Bridge microarchitecture is used in second-generation Intel Core (i3, i5, and i7 series) processors. Third- and fourth-generation Intel Core processors are based on the Ivy Bridge and Haswell microarchitectures, respectively. The server and workstation oriented Xeon E3, E3 v2, and E3 v3 processor families are also based on the Sandy Bridge, Ivy Bridge, and Haswell microarchitectures, respectively. The Intel product information website that's listed in Appendix C contains additional information regarding processor families and their corresponding microarchitectures.

X86-AVX Execution Environment

The following section examines the x86-AVX execution environment, which includes its register set and supported data types. It also explains the new three-operand assembly language instruction syntax that's used by x86-AVX. The subject matter of this section assumes that you are familiar with the x86-SSE material presented in Chapters 7 through 11.

X86-AVX Register Set

X86-AVX adds eight new 256-bit wide registers named YMM0-YMM7 to the x86 platform. These directly-addressable registers can be used to manipulate a variety of data types, including packed integer, packed floating-point, and scalar floating-point values. The low-order 128 bits of each YMM register are aliased with the corresponding XMM register, as illustrated in Figure 12-1. X86-AVX instructions can use either the XMM or YMM registers as operands. If an x86-AVX instruction uses an XMM register as a destination operand, the processor zeroes the upper 128 bits of the matching YMM register during execution. On processors that support x86-AVX, the high-order 128 bits of a YMM register are never modified during execution of an x86-SSE instruction. The default handling of a YMM register's upper 128 bits during instruction execution is discussed further later in this chapter.

255	128	127	0
	YMM 0		XMM 0
	YMM 1		XMM 1
	YMM 2		XMM 2
	YMM 3		XMM 3
	YMM 4		XMM 4
	YMM 5		XMM 5
	YMM 6		XMM 6
	YMM 7		XMM 7

Figure 12-1. X86-AVX register set in x86-32 mode

X86-AVX Data Types

AVX supports SIMD operations using 256-bit and 128-bit wide packed single-precision or packed double-precision floating-point operands. A 256-bit wide YMM register or memory location can hold eight single-precision or four double-precision values, as shown in Figure 12-2. When used with a 128-bit wide XMM register or memory location, an AVX instruction can process four single-precision or two double-precision values. Like SSE and SSE2, AVX manipulates the low-order doubleword or quadword of an XMM register when performing scalar single-precision or double-precision floating-point arithmetic, respectively.

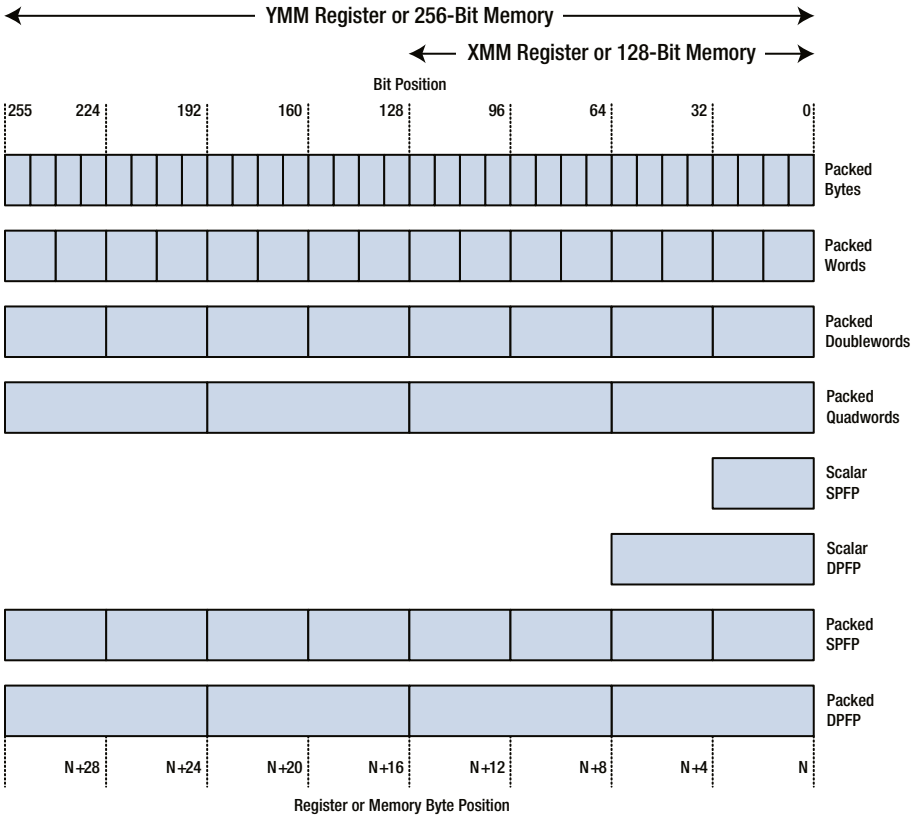

Figure 12-2. X86-AVX data types

AVX also accommodates use of the XMM registers to perform SIMD operations using a variety of packed integer operands, including bytes, words, doublewords, and quadwords. AVX2 extends the packed integer processing capabilities of AVX to the YMM registers and 256-bit wide memory locations. Figure 12-2 also shows these data types.

X86-AVX Instruction Syntax

Perhaps the most noteworthy aspect of x86-AVX is its use of a contemporary assembly language instruction syntax. Most x86-AVX instructions use a three-operand format that consists of two source operands and one destination operand. The general syntax that's employed for these instructions is `InstrMnemonic DesOp, SrcOp1, SrcOp2`, where `InstrMnemonic` signifies the x86-AVX instruction mnemonic, and `DesOp`, `SrcOp1`, and `SrcOp2` denote the destination and source operands, respectively. The remaining x86-AVX instructions require either one or three source operands. Nearly all x86-AVX instruction source operands are non-destructive (i.e., the operand is not modified during instruction execution), except in cases where a destination operand register is the same as one of the source operand registers.

Table 12-2 contains a few examples that illustrate the general syntax of an x86-AVX instruction. Note that all of the instruction mnemonics begin with the letter v. Later in this chapter, you learn that many x86-AVX instructions are straightforward extensions of a corresponding x86-SSE instruction. This extension becomes readily apparent if you remove the v prefix from the instruction mnemonics shown in Table 12-2.

Table 12-2. X86-AVX Instruction Syntax Examples

Instruction	Operation
vaddpd ymm0,ymm1,ymm2 (Packed double-precision floating-point addition)	$ymm0[63:0] = ymm1[63:0] + ymm2[63:0]$ $ymm0[127:64] = ymm1[127:64] + ymm2[127:64]$ $ymm0[191:128] = ymm1[191:128] + ymm2[191:128]$ $ymm0[255:192] = ymm1[255:192] + ymm2[255:192]$
vmulps xmm0,xmm1,xmm2 (Packed single-precision floating-point multiplication)	$xmm0[31:0] = xmm1[31:0] * xmm2[31:0]$ $xmm0[63:31] = xmm1[63:31] * xmm2[63:31]$ $xmm0[95:64] = xmm1[95:64] * xmm2[95:64]$ $xmm0[127:96] = xmm1[127:96] * xmm2[127:96]$ $ymm0[255:128] = 0$
vunpcklps xmm0,xmm1,xmm2 (Unpack low single-precision floating-point values)	$xmm0[31:0] = xmm1[31:0]$ $xmm0[63:31] = xmm2[31:0]$ $xmm0[95:64] = xmm1[63:32]$ $xmm0[127:96] = xmm2[63:32]$ $ymm0[255:128] = 0$
vpxor ymm0,ymm1,ymm2 (Logical exclusive-or)	$ymm0[255:0] = ymm1[255:0] \wedge ymm2[255:0]$
vmovdqqa ymm0,ymm1 (Move aligned double quadwords)	$ymm0[255:0] = ymm1[255:0]$
vbldpd ymm0,ymm1,ymm2,06h (Blend packed double-precision floating-point values)	$ymm0[63:0] = ymm1[63:0]$ $ymm0[127:64] = ymm2[127:64]$ $ymm0[191:128] = ymm2[191:128]$ $ymm0[255:192] = ymm1[255:192]$

X86-AVX's ability to support a three-operand instruction syntax is due to a new instruction-encoding prefix. The vector extension (VEX) prefix enables x86-AVX instructions to be encoded using a more efficient format than the prefixes used for x86-SSE instructions. It also provides a migration path for future x86-AVX instruction enhancements. Most of the new general-purpose register instructions also use the VEX prefix.

X86-AVX Feature Extensions

Concomitant with the introduction of AVX and AVX2 are several new feature extensions to the x86 platform. The feature extensions include half-precision floating-point conversions, FMA computations, and general-purpose register instruction enhancements. The remainder of this section briefly outlines these extensions along with some caveats regarding their use that programmers need to be aware of.

Processors based on the Ivy Bridge and Haswell microarchitectures incorporate instructions that carry out half-precision floating-point conversions. Compared to a standard single-precision floating-point value, a half-precision value is a reduced-precision floating-point number that contains three fields: an exponent (5 bits), a significand (11 bits), and a sign bit. Each half-precision floating-point value is 16 bits wide; the leading digit of the significand is implied. Compatible processors include instructions that can convert packed half-precision floating-point values to packed single-precision floating-point and vice versa. However, it is not possible to perform common arithmetic calculations such as addition, subtraction, multiplication, and division using half-precision floating-point values. Half-precision floating-point values are primarily intended to reduce space requirements, either in memory or on a data storage device. The drawbacks of using half-precision floating-point values are reduced precision and limited range.

Haswell-based processors also include instructions that perform FMA operations. A FMA instruction combines multiplication and addition (or subtraction) into a single operation. More specifically, a fused-multiply-add (or fused-multiply-subtract) calculation performs a floating-point multiplication followed by a floating-point addition (or subtraction) using a single rounding operation. As an example, consider the expression $a = (b * c) + d$. Using standard floating-point arithmetic, the processor initially performs a multiplication that includes a rounding operation. This is followed by a floating-point addition and another rounding operation. If the expression is evaluated using FMA arithmetic, the processor does not round the intermediate product $b * c$. Rounding is carried out only once using the final product-sum $(b * c) + d$. The FMA instructions can be used to improve the performance and accuracy of multiply-accumulate computations such as dot products and matrix multiplications. Many signal-processing algorithms also make extensive use of FMA operations. The FMA instruction set supports operations using both scalar and packed single-precision and double-precision floating-point values.

The final feature extension adds new general-purpose register instructions. These instructions, which are available on Haswell processors, support enhanced bit manipulations, flagless register rotate and shift operations, and flagless unsigned integer multiplication. The flagless rotate, shift, and multiplication instructions do not affect any of the status flags in the EFLAGS register. This can improve the performance of many integer-oriented calculations and algorithms. Most of the new general-purpose instructions registers also use the new three-operand assembly-language syntax.

The extensions described in the previous paragraphs are considered distinct processor features. What this means from a programming perspective is that a software developer cannot assume the corresponding instruction sets are available based on whether or not the processor supports AVX or AVX2. For example, a future processor that targets mobile devices might include support for AVX2 but not FMA in order to achieve a specific thermal design point. The presence of a particular feature extension should always be explicitly tested for using the `cpuid` instruction. In Chapter 16, you examine some sample code that illustrates how to use this instruction in order to detect specific processor feature extensions.

X86-AVX Instruction Set Overview

The x86-AVX instruction set can be broadly partitioned into three groups. The first group includes the x86-SSE instructions that have been promoted to exploit the new three-operand syntax using either 128-bit or 256-bit wide operands. The next group consists of new instructions that were introduced with AVX or AVX2. The final group includes x86-AVX feature extension instructions, including half-precision floating point conversions, FMA, and new general-purpose register instructions.

Before proceeding to the overview, there are some syntactical and execution commonalities regarding the x86-AVX instruction set that warrant a few comments. As mentioned earlier in this chapter, all x86-AVX instructions employ an assembly language syntax that consists of an instruction mnemonic, a destination operand, and up to three source operands. If an instruction performs a data transfer operation, the destination operand can specify a location in memory; otherwise, it must be an XMM or YMM register. Only one of the source operands can specify a location in memory; the remaining source operands must be an XMM register, a YMM register, or an immediate operand.

X86-AVX relaxes the alignment requirements of instruction operands in memory. Except for data transfer instructions that explicitly reference a 16-byte or 32-byte aligned operand in memory, proper alignment of an x86-AVX instruction operand in memory is not required. Despite this alignment relaxation, it is strongly recommended that all 16-byte and 32-byte operands in memory be properly aligned for best possible performance. X86-SSE instructions that execute on processors that support x86-AVX must still use properly aligned memory operands.

Promoted x86-SSE Instructions

Most x86-SSE instructions that manipulate 128-bit wide operands have a corresponding x86-AVX instruction. This includes packed single-precision floating-point, double-precision floating-point, and integer values. For example, the x86-SSE instruction `mulps xmm0, xmm1` multiplies the packed single-precision floating-point values in registers XMM0 and XMM1 and saves the packed product result to register XMM0. The parallel x86-AVX instruction is `vmulps xmm0, xmm0, xmm1`. Another example is the x86-SSE add packed byte integers instruction `paddb xmm0, xmm1` and its corresponding x86-AVX instruction is `vpaddb xmm0, xmm0, xmm1`. Note that in both of these examples, register XMM0 is used destructively. Non-destructive examples of the x86-AVX instructions include `vmulps xmm0, xmm1, xmm2` and `vpaddb xmm0, xmm1, xmm2`, whose execution does not modify the values in XMM1 and XMM2.

Nearly all 128-bit wide x86-SSE instructions have an x86-AVX form that can be used with 256-bit wide operands. For example, the `vsubpd ymm7, ymm0, ymm1` instruction performs a packed floating-point subtraction using four pairs of double-precision values. The `vdivps ymm7, ymm0, ymm1` instruction performs packed single-precision floating-point division using eight value pairs, and `vpsubb ymm7, ymm0, ymm1` subtracts 32 pairs of integer byte values.

Within a processor, each 256-bit AVX register is partitioned into an upper and lower 128-bit lane. Most x86-AVX instructions carry out their operations using same-lane source and destination operand elements. This independent lane execution tends to be inconspicuous when using x86-AVX instructions that perform arithmetic calculations.

However, when using instructions that re-order the data elements of a packed quantity (such as `vshufps` and `vpunpcklwd`), the effect of separate execution lanes is more evident, as illustrated in Figure 12-3. In these examples, the floating-point shuffle and word unpack operations are carried out independently in both the upper (bits 255:128) and lower (bits 127:0) double quadwords.

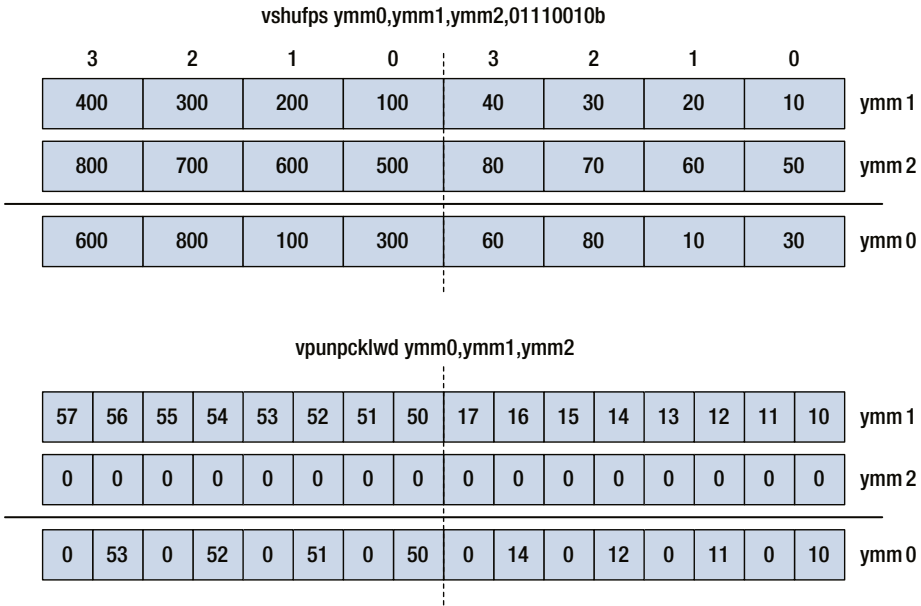

Figure 12-3. Examples of x86-AVX instruction execution using independent lanes

The X86-AVX instruction set also supports three-operand forms of the x86-SSE scalar floating-point instructions. The `vaddss xmm0,xmm1,xmm2` instruction, for example, adds the scalar single-precision floating-point values in XMM1 and XMM2 and saves the sum to XMM0. The instruction `vmulsd xmm0,xmm1,xmm2` multiplies the scalar double-precision values in XMM1 and XMM2; the resultant product is then saved to register XMM0. A comprehensive list of all x86-SSE to x86-AVX promoted instructions is included in the Intel and AMD reference manuals, which can be downloaded from the websites listed in Appendix C.

The high degree of instructional symmetry between x86-SSE and x86-AVX and the aliasing of the XMM and YMM register sets introduces a few programming issues that software developers need to keep in mind. The first issue relates to the processor’s handling of a YMM register’s high-order 128 bits when the corresponding XMM register is used as a destination operand. When executing on a processor that supports x86-AVX technology, an x86-SSE instruction that uses an XMM register as a destination operand will never access the upper 128 bits of the corresponding YMM register. However, the equivalent

x86-AVX instruction will zero the upper 128 bits of the respective YMM register. Consider, for example, the following instances of the (v)cvtps2pd (Convert Packed Single-Precision to Packed Double-Precision Floating Point Values) instruction:

```
cvtps2pd xmm0,xmm1
vcvtps2pd xmm0,xmm1
vcvtps2pd ymm0,ymm1
```

The x86-SSE cvtps2pd instruction converts the two packed single-precision floating-point values in the low-order quadword of XMM1 to double-precision floating-point and saves the result in register XMM0. The high-order 128 bits of register YMM0 are not modified. The first vcvtps2pd instruction performs the same packed single-precision to packed double-precision conversion operation; it also zeros the high-order 128 bits of YMM0. The second vcvtps2pd instruction converts the four packed single-precision floating-point values in the low-order 128 bits of YMM1 to packed double-precision floating-point values and saves the result to YMM0.

All x86-AVX scalar floating-point instructions set the upper 128 bit of a YMM register to zero. These instructions also copy unused bits of the first source operand to the destination operand, as shown in Table 12-3, using the x86-AVX vaddss and vaddsd (Add Scalar Single/Double Precision Floating-Point Values) instructions. Table 12-3 also illustrates operation of the vsqrtss and vsqrtsd (Compute Scalar Square Root of Single/Double Precision Floating-Point Value) instructions. Note that these instructions require two source operands even though they perform a unary operation using only the second source operand.

Table 12-3. Examples of x86-AVX Scalar Floating-Point Instructions

Instruction	Operation
vaddss xmm0,xmm1,xmm2 (Add scalar single-precision floating-point value)	$xmm0[31:0] = xmm1[31:0] + xmm2[31:0]$ $xmm0[127:32] = xmm1[127:32]$ $ymm0[255:128] = 0$
vaddsd xmm0,xmm1,xmm2 (Add scalar single-precision floating-point value)	$xmm0[63:0] = xmm1[63:0] + xmm2[63:0]$ $xmm0[127:64] = xmm1[127:64]$ $ymm0[255:128] = 0$
vsqrtss xmm0,xmm1,xmm2 (Square root of single-precision floating-point value)	$xmm0[31:0] = \text{sqrt}(xmm2[31:0])$ $xmm0[127:32] = xmm1[127:32]$ $ymm0[255:128] = 0$
vsqrtsd xmm0,xmm1,xmm2 (Square root of double-precision floating-point value)	$xmm0[63:0] = \text{sqrt}(xmm2[63:0])$ $xmm0[127:64] = xmm1[127:64]$ $ymm0[255:128] = 0$

The last issue that programmers need to be aware of involves the intermixing of x86-AVX and x86-SSE instructions. Programs are allowed to intermix x86-AVX and x86-SSE instructions but any intermixing should be kept to a minimum in order to avoid internal processor state transition penalties that can affect performance. These penalties can occur if the processor is required to preserve the upper 128 bits of each YMM register during a transition from executing x86-AVX to executing x86-SSE instructions. State transition penalties can be completely avoided by using the `vzeroupper` (Zero Upper Bits of YMM Registers) instruction, which zeroes the upper 128 bits of all YMM registers. This instruction should be used prior to any transition from 256-bit x86-AVX code (i.e., any x86-AVX instruction that uses a YMM register) to x86-SSE code.

One common use of the `vzeroupper` instruction is by a public function that uses 256-bit x86-AVX instructions. These types of functions should include a `vzeroupper` instruction prior to the execution of any `ret` instruction since this prevents processor state transition penalties from occurring in any high-level language code that uses x86-SSE instructions. The `vzeroupper` instruction should also be employed before calling any library functions that might contain x86-SSE code. The sample code in Chapters 14 through 16 contains examples that demonstrate proper use of the `vzeroupper` instruction. Functions can also use the `vzeroall` (Zero All YMM Registers) instruction in order to avoid x86-AVX /x86-SSE state transition penalties.

New Instructions

The following section briefly reviews the new x86-AVX instructions. These instructions have been partitioned into the following subgroups:

- Broadcast
- Blend
- Permute
- Extract and Insert
- Masked Move
- Variable Bit Shift
- Gather

The instruction table summaries list the x86-AVX release (or version) that's required in order to use the instruction. If a table entry lists both AVX and AVX2, it means that additional forms of the instruction were added in AVX2.

Broadcast

The broadcast group contains instructions that copy (or broadcast) a single data value to multiple elements of a packed destination operand. Broadcast instructions are available for all packed data types, including single-precision floating-point, double-precision floating-point, and integers. Table 12-4 summarizes the broadcast instructions.

Table 12-4. X86-AVX Broadcast Instructions

Mnemonic	Description	Version
<code>vbroadcastss</code>	Copies a SPFP value to all elements of the destination operand.	AVX AVX2
<code>vbroadcastsd</code>	Copies a DPFP value to all elements of the destination operand.	AVX AVX2
<code>vbroadcastf128</code>	Copies a packed 128-bit floating-point value from memory to the lower and upper double quadwords of the destination operand.	AVX
<code>vbroadcasti128</code>	Copies a packed 128-bit integer value from memory to the lower and upper double quadwords of the destination operand.	AVX2
<code>vpbroadcastb</code> <code>vpbroadcastw</code> <code>vpbroadcastd</code> <code>vpbroadcastq</code>	Copies an 8-bit, 16-bit, 32-bit, or 64-bit integer value to all elements of the destination operand.	AVX2

Blend

The blend group contains instructions that conditionally merge the elements of two packed data types. These instructions are shown in Table 12-5.

Table 12-5. X86-AVX Blend Instructions

Mnemonic	Description	Version
<code>vpblendd</code>	Conditionally copies doubleword values from the first two source operands to the destination operand using the control mask that's specified by an immediate value.	AVX2

Permute

The permute group includes instructions that reorder or replicate the elements of a packed data type. Multiple packed data types are supported, including doublewords, single-precision floating-point, and double-precision floating point. Table 12-6 outlines these instructions.

Table 12-6. X86-AVX Permute Instructions

Mnemonic	Description	Version
vpermd	Permutates the doubleword elements of the second source operand using the indices specified by the first source operand. This instruction can be used to reorder or replicate the doubleword values in the second source operand.	AVX2
vpermpd	Permutates the DPF elements of the first source operand using the indices specified by an immediate operand. This instruction can be used to reorder or replicate the DPF values in the source operand.	AVX2
vpermps	Permutates the SPFP elements of the second source operand using the indices specified by the first source operand. This instruction can be used to reorder or replicate SPFP values in the second source operand.	AVX2
vpermq	Permutates the quadword elements of the first source operand using the indices specified by an immediate operand. This instruction can be used to reorder or replicate the quadword values in the source operand.	AVX2
vperm2i128	Permutates the packed 128-bit integer values of the first two source operands using the indices specified by an immediate mask. This instruction can be used to reorder, replicate, or interleave the values in the first two source operands.	AVX2
vpermilpd	Permutates the DPF values in the first source operand using the control value specified by the second source operand. Each 128-bit lane is permuted independently.	AVX
vpermilps	Permutates the SPFP values in the first source operand using the control value specified by the second source operand. Each 128-bit lane is permuted independently.	AVX
vperm2f128	Permutates the packed 128-bit floating-point values of the first two source operands using the indices specified by an immediate mask. This instruction can be used to reorder, replicate, or interleave the values in the first two source operands.	AVX

Extract and Insert

The extract and insert group contains instructions that copy 128-bit packed integer values between a YMM register and an XMM register or memory location. Table 12-7 summarizes the instructions in the extract and insert group.

Table 12-7. X86-AVX Extract and Insert Instructions

Mnemonic	Description	Version
vextracti128	Extracts the low-order or high-order packed 128-bit integer value from the source operand and copies it to the destination operand. The value to extract is specified by an immediate operand.	AVX2
vinseri128	Inserts a 128-bit packed integer value from the second source operand into the destination operand. The location in the destination operand (lower or upper 128-bits) is specified by an immediate operand. The remaining destination operand element is filled using the corresponding element of the first source operand.	AVX2

Masked Move

The masked move group includes instructions that perform conditional moves of the elements in a packed data value. A control mask determines whether or not a specific element is copied from the source operand to the destination operand. If the element is not copied, zero is saved to the corresponding destination operand element. Table 12-8 lists the masked move instructions.

Table 12-8. X86-AVX Masked Move Instructions

Mnemonic	Description	Version
vmaskmovps	Conditionally copies the SPFP elements of the second source operand to the corresponding elements in the destination operand according to a control mask that's specified by the first source operand.	AVX
vmaskmovpd	Conditionally copies the DFP elements of the second source operand to the corresponding elements in the destination operand according to a control mask that's specified by the first source operand.	AVX
vpmaskmovd	Conditionally copies the doubleword elements of the second source operand to the corresponding elements in the destination operand according to a control mask that's specified by the first source operand.	AVX2
vpmaskmovq	Conditionally copies the quadword elements of the second source operand to the corresponding elements in the destination operand according to a control mask that's specified by the first source operand.	AVX2

Variable Bit Shift

The variable bit shift group contains instructions that perform arithmetic or logical shifts on the elements of a packed doubleword or quadword data value using different bit counts. These instructions are summarized in Table 12-9.

Table 12-9. X86-AVX Variable Bit Shift Instructions

Mnemonic	Description	Version
<code>vpsllvd</code> <code>vpsllvq</code>	Shifts each doubleword/quadword data element of the first source operand to the left while shifting in 0s. The bit shift count is specified by the corresponding data element of the second source operand.	AVX2
<code>vpsravd</code>	Shifts each doubleword data element of the first source operand to the right while shifting in the element's sign bit. The bit shift count is specified by the corresponding data element of the second source operand.	AVX2
<code>vpsrldv</code> <code>vpsrldq</code>	Shifts each doubleword/quadword data element of the first source operand to the right while shifting in 0s. The bit shift count is specified by the corresponding data element of the second source operand.	AVX2

Gather

The gather group contains instructions that conditionally copy data elements from a memory-based array into an XMM or YMM register. These instructions use a special memory addressing mode called vector scale-index-base (VSIB). VSIB memory addressing employs the following components to specify an operand:

- *Base*—A general-purpose register that points to the start of an array in memory.
- *Scale*—The array element size scale factor (1, 2, 4, or 8).
- *Index*—A vector register (XMM or YMM) that contains the signed doubleword or signed quadword array indices.
- *Displacement*—An optional fixed offset from the start of the array.

Depending on the instruction, the vector register must contain two, four, or eight signed-integer indices. The indices are used to select elements from the array. Figure 12-4 illustrates execution of the instruction `vgatherdps xmm0, [esi+xmm1*4], xmm2`. In this example, register ESI points to the start of an array containing single-precision floating-point values. Register XMM1 holds four signed doubleword array indices and register XMM2 contains a conditional copy control mask.

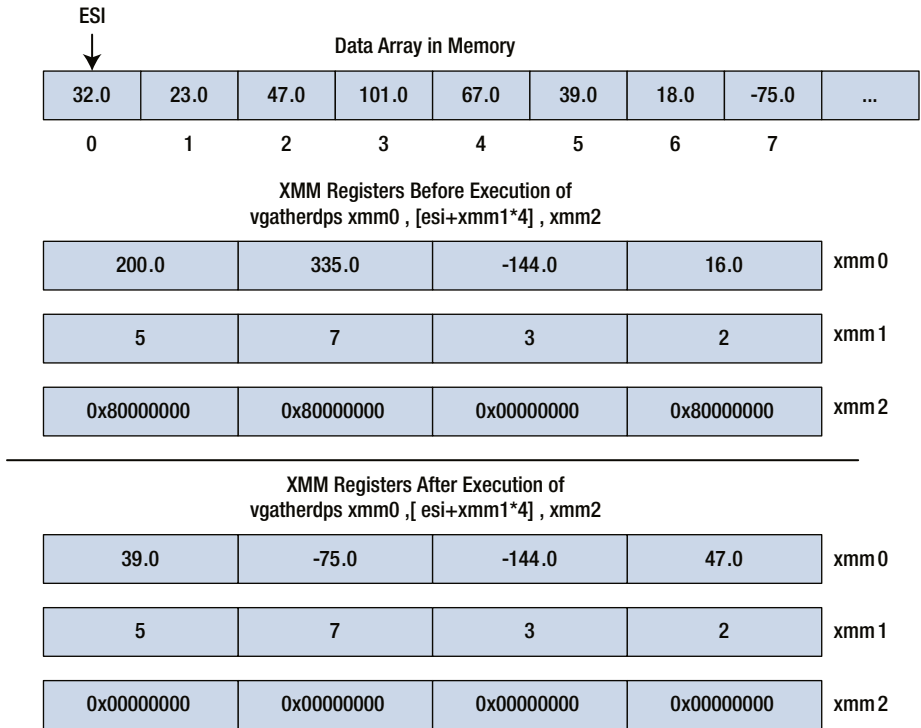

Figure 12-4. Illustration of the `vgatherdps` instruction

The destination operand and second source operand (the copy control mask) of a gather group instruction must be an XMM or YMM register. The first source operand specifies the VSIB components (i.e., array base register, scale factor, array indices, and optional displacement). Note that the gather instructions do not check for an invalid array index; the use of an invalid array index will yield an incorrect result. Table 12-10 summarizes the gather group instructions. In this table, each gather instruction mnemonic uses the prefix `vgatherd` or `vgatherq` to specify doubleword or quadword array indices, respectively.

Table 12-10. *X86-AVX Gather Instructions*

Mnemonic	Description	Version
<code>vgatherdpd</code> <code>vgatherqpd</code>	Conditionally copies two or four double-precision floating-point values from a memory-based array using VSIB addressing.	AVX2
<code>vgatherdps</code> <code>vgatherqps</code>	Conditionally copies four or eight single-precision floating-point values from a memory-based array using VSIB addressing.	AVX2
<code>vgatherdd</code> <code>vgatherqd</code>	Conditionally copies four or eight doubleword values from a memory-based array using VSIB addressing.	AVX2
<code>vgatherdq</code> <code>vgatherqq</code>	Conditionally copies two or four quadword values from a memory-based array using VSIB addressing.	AVX2

Feature Extension Instructions

The following section describes the x86-AVX concomitant feature extension instructions, including half-precision floating-point conversions, FMA, general-purpose register enhancements. In order to use any of the instructions in these groups, they must be supported by the processor as indicated by the corresponding `cpuid` instruction feature flag. The half-precision and FMA instruction groups also require a processor that supports AVX or AVX2, respectively, along with an operating system that performs YMM register state saves during thread and process context switches.

Half-Precision Floating-Point

The half-precision floating-point group contains instructions that perform packed half-precision floating-point to single-precision floating-point conversions and vice versa. Processor support for these instructions is indicated via the `cpuid` F16C feature flag. Table 12-11 contains a synopsis of the half-precision floating-point conversion instructions.

Table 12-11. X86-AVX Half-Precision Floating-Point Instructions

Mnemonic	Description	Version
<code>vcvtph2ps</code>	Converts four or eight half-precision floating-point values in the source operand to single-precision floating-point values and saves the results to the destination operand. The number of performed conversions depends on the size of the destination operand, which must be an XMM or YMM register.	AVX
<code>vcvtps2ph</code>	Converts four or eight single-precision floating-point values in the source operand to half-precision floating-point values and saves the results to the destination operand. The number of performed conversions depends on the size of the first source operand, which must be an XMM or YMM register. This instruction also requires an immediate operand, which specifies the rounding mode.	AVX

FMA

The FMA (fused-multiply-add) group contains instructions that perform fused-multiply-add or fused-multiply-subtract operations using packed floating-point or scalar floating-point operands. The FMA instructions carry out their computations using one of the following generic expressions:

$$a = (b * c) + d$$

$$a = (b * c) - d$$

$$a = -(b * c) + d$$

$$a = -(b * c) - d$$

In each of these expressions, the processor applies only one rounding operation to calculate the final result, which can improve the speed and accuracy of the calculation.

All FMA instruction mnemonics employ a three-digit operand-ordering scheme that specifies the source operands to use for multiplication and addition (or subtraction). The first digit specifies the source operand to use as the multiplicand; the second digit specifies the source operand to use as the multiplier; and the third digit specifies the source operand that is added to (or subtracted from) the product. For example, consider the following instruction: `vfmadd132sd xmm0, xmm1, xmm2` (Fused Multiply-Add of Scalar Double-Precision Floating-Point Values). In this example, registers XMM0, XMM1, and XMM2 are source operands 1, 2, and 3, respectively. The `vfmadd132sd` instruction computes $(xmm0[63:0] * xmm2[63:0]) + xmm1[63:0]$, rounds the product-sum according to the rounding mode specified by MXCSR.RC, and saves the final result to `xmm0[63:0]`.

The FMA instruction set supports operations using packed and scalar single-precision and double-precision floating-point data values. Packed FMA operations can be performed using either the XMM or YMM registers. The XMM (YMM) registers support packed FMA calculations using two (four) double-precision or four (eight) single-precision

floating-point values. Scalar FMA calculations must be performed using the XMM register set. For all FMA instructions, the first and second source operands must be a register. The third source operand can be a register or a memory location. If an FMA instruction uses an XMM register as a destination operand, the high-order 128 bits of the corresponding YMM register are set to zero. FMA instructions carry out their sole rounding operation using the mode that's specified by MXCSR.RC, as explained in the previous paragraph.

The remainder of this section reviews the FMA instruction set, which has been partitioned into six subgroups in order to facilitate comprehension. In the subgroup description tables, the following two-letter suffixes are used by the instruction mnemonics: *pd* (packed double-precision floating-point), *ps* (packed single-precision floating-point), *sd* (scalar double-precision floating-point), and *ss* (scalar single-precision floating-point). The symbols *src1*, *src2*, and *src3* denote the three source operands, and *des* signifies the destination operand, which is the same as *src1*.

VFMADD Subgroup

The VFMADD subgroup contains instructions that perform fused-multiply-add operations using either packed floating-point or scalar floating-point data types. These instructions are summarized in Table 12-12.

Table 12-12. FMA VFMADD Subgroup Instructions

Mnemonics	Operation
<code>vfmadd132(pd ps sd ss)</code>	$des = src1 * src3 + src2$
<code>vfmadd213(pd ps sd ss)</code>	$des = src2 * src1 + src3$
<code>vfmadd231(pd ps sd ss)</code>	$des = src2 * src3 + src1$

VFMSUB Subgroup

The VFMSUB subgroup contains instructions that perform fused-multiply-subtract operations using either packed floating-point or scalar floating-point data types. Table 12-13 lists these instructions and their operations.

Table 12-13. FMA VFMSUB Subgroup Instructions

Mnemonics	Operation
<code>vfmsub132(pd ps sd ss)</code>	$des = src1 * src3 - src2$
<code>vfmsub213(pd ps sd ss)</code>	$des = src2 * src1 - src3$
<code>vfmsub231(pd ps sd ss)</code>	$des = src2 * src3 - src1$

VFMADDSUB Subgroup

The VFMADDSUB subgroup includes instructions that perform fused-multiply operations on packed data types using addition for the odd elements and subtraction for the even elements. Table 12-14 outlines these instructions.

Table 12-14. FMA VFMADDSUB Subgroup Instructions

Mnemonics	Operation
vfmaddsub132(pd ps)	des = src1 * src3 + src2 (odd elements) des = src1 * src3 - src2 (even elements)
vfmaddsub213(pd ps)	des = src2 * src1 + src3 (odd elements) des = src2 * src1 - src3 (even elements)
vfmaddsub231(pd ps)	des = src2 * src3 + src1 (odd elements) des = src2 * src3 - src1 (even elements)

VFMSUBADD Subgroup

The VFMSUBADD subgroup contains instructions that perform fused-multiply operations on packed data types using subtraction for the odd elements and addition for the even elements. Table 12-15 summarizes these instructions.

Table 12-15. FMA VFMSUBADD Subgroup Instructions

Mnemonics	Operation
vfmsubadd132(pd ps)	des = src1 * src3 - src2 (odd elements) des = src1 * src3 + src2 (even elements)
vfmsubadd213(pd ps)	des = src2 * src1 - src3 (odd elements) des = src2 * src1 + src3 (even elements)
vfmsubadd231(pd ps)	des = src2 * src3 - src1 (odd elements) des = src2 * src3 + src1 (even elements)

VFMADD Subgroup

The VFMADD subgroup contains instructions that perform fused negative multiply-add operations. Table 12-16 lists these instructions.

Table 12-16. FMA VFMADD Subgroup Instructions

Mnemonics	Operation
<code>vfnmadd132(pd ps sd ss)</code>	$des = -(src1 * src3) + src2$
<code>vfnmadd213(pd ps sd ss)</code>	$des = -(src2 * src1) + src3$
<code>vfnmadd231(pd ps sd ss)</code>	$des = -(src2 * src3) + src1$

VFNMSUB Subgroup

The VFNMSUB subgroup contains instructions that perform fused negative multiply-subtract operations. Table 12-17 describes the operation of these instructions.

Table 12-17. FMA VFNMSUB Subgroup Instructions

Mnemonics	Operation
<code>vfnmsub132(pd ps sd ss)</code>	$des = -(src1 * src3) - src2$
<code>vfnmsub213(pd ps sd ss)</code>	$des = -(src2 * src1) - src3$
<code>vfnmsub231(pd ps sd ss)</code>	$des = -(src2 * src3) - src1$

General-Purpose Register

The general-purpose register group includes new instructions that support enhanced bit manipulations, flagless rotate and shift operations, and flagless unsigned integer multiplication. These instructions are summarized in Table 12-18. Processor support for these instructions is indicated via the CPUID feature flags, which are also shown in Table 12-18.

Table 12-18. *General-Purpose Register Instructions*

Mnemonic	Description	Feature Flag
<code>andn</code>	Performs a bitwise logical AND of the inverted first source operand with the second source operand and saves the result to the destination operand. The first source operand and destination operand must be a general-purpose register. The second source operand can be a memory location or a general-purpose register.	BMI1
<code>bextr</code>	Extracts a bit field from the first source operand using an index and length that is specified by the second source operand. The result is written to the destination operand. The second source operand and destination operand must be general-purpose registers. The first source operand can be a memory location or a general-purpose register.	BMI1
<code>bsl</code>	Extracts the lowest 1 bit from the source operand and sets the corresponding bit in the destination operand. All other destination operand bits are set to zero. The source operand must be a memory location or general-purpose register. The destination operand must be a general-purpose register.	BMI1
<code>bsmsk</code>	Determines the bit position of the lowest set bit in the source operand; sets this bit and all lower bits to 1 in the destination operand. Non-mask bits in the destination operand are set to zero. The source operand can be a memory location or a general-purpose register. The destination operand must be a general-purpose register.	BMI1
<code>bsr</code>	Copies the source operand to the destination operand; resets the destination operand bit corresponding to the lowest 1 bit in the source operand. The source operand can be a memory location or a general-purpose register. The destination operand must be a general-purpose register.	BMI1
<code>bzhi</code>	Copies the first source operand to the destination operand; clears the high-order bits of the destination operand using the index value that is specified by the second source operand. The destination operand and second source operand must be general-purpose registers. The first source operand can be a memory location or a general-purpose register.	BMI2

(continued)

Table 12-18. (continued)

Mnemonic	Description	Feature Flag
lzcnt	Counts the number of leading zero bits in the source operand and saves this value to the destination operand. If the value of the source operand is zero, the destination operand is set to the operand size. This instruction is used as an alternative to the bsr instruction, which leaves the destination operand undefined if the value of the source operand is zero.	LZCNT
mulx	Performs an unsigned multiplication between register EDX and the source operand. The high and low parts of the product are saved to the first and second destination operands, respectively. None of the status bits in EFLAGS are updated. The source operand can be a memory location or a general-purpose register. The first and second destination operands must be general-purpose registers.	BMI2
pdep	Transfers and scatters the low-order bits of the first source operand to the destination operand using a bit mask that is specified by the second source operand. Destination operand bits not included in the bit mask are set to zero. The destination operand and first source operand must be general-purpose registers. The second source operand can be a memory location or a general-purpose register.	BMI2
pext	Transfers bits from the first source operand to the low-order bit positions of the destination operand using a bit mask that is specified by the second source operand. The destination operand and first source operand must be general-purpose registers. The second source operand can be a memory location or a general-purpose register.	BMI2
rdrand	Loads a hardware-generated random number into the specified destination operand, which must be a general-purpose register.	RDRAND
roxr	Rotates the bits of the source operand using a count value that is specified by an immediate operand; the result is saved to the destination operand. This instruction does not update the status bits in EFLAGS. The source operand can be a memory location or a general-purpose register. The destination operand must be a general-purpose register.	BMI2

(continued)

Table 12-18. (continued)

Mnemonic	Description	Feature Flag
sarx shlx shrx	Shifts (right-arithmetic, left-logical, or right-logical) the first source operand using a count value that is specified by the second source operand. The result is saved to the destination operand. None of the status bits in EFLAGS are updated. The first source operand can be a memory location or a general-purpose register. The second source operand and destination operand must be general-purpose registers.	BMI2
tzcnt	Counts the number of trailing zero bits in the source operand and saves this value to the destination operand. If the value of the source operand is zero, the destination operand is set to the operand size. This instruction is used as an alternative to the <code>bsf</code> instruction, which leaves the destination operand undefined if the value of the source operand is zero.	BMI1

Summary

In this chapter, you learned about key aspects of x86-AVX, including its execution environment, supported data types, and assembly language instruction syntax. You also explored several x86-AVX associated feature extensions, including half-precision floating-point conversions, FMA operations, and enhancements to the general-purpose register instruction set. Despite your newly-acquired knowledge, you've only reached a sojourn in your x86-AVX pedagogical odyssey. The journey continues in Chapters 13 through 16, which present a series of sample programs that elucidate the subject material presented in this chapter.



X86-AVX Programming - Scalar Floating-Point

In the previous chapter, you learned about the computational resources of x86-AVX, including its execution environment, supported data types, and instruction set. This chapter introduces x86-AVX programming and focuses on its scalar floating-point capabilities. It includes a couple of sample programs that illustrate how to perform basic scalar floating-point arithmetic. This chapter also contains a set of sample programs that demonstrate advanced scalar floating-point programming using x86-AVX. All of the sample programs in this chapter require a processor that supports AVX. Appendix C lists a couple of freely available utilities that you can use to determine the version of x86-AVX that's supported by your PC's processor and its operating system.

Programming Fundamentals

In this section, you learn how to perform essential scalar floating-point operations using the x86-AVX instruction set. The first sample program demonstrates basic scalar floating-point arithmetic, including addition, subtraction, multiplication, and division. The second sample program elucidates scalar floating-point compare operations. Both sample programs also delve into the ancillary actions that are carried out by most x86-AVX instructions compared to their x86-SSE counterparts.

Scalar Floating-Point Arithmetic

The first sample program that you examine in this section is called `AvxScalarFloatingPointArithmetic`. This program demonstrates how to perform basic scalar double-precision floating-point arithmetic operations using the x86-AVX instruction set. Listings 13-1 and 13-2 contain the C++ and assembly language source code, respectively, for sample program `AvxScalarFloatingPointArithmetic`.

Listing 13-1. AvxScalarFloatingPointArithmetic.cpp

```

#include "stdafx.h"

extern "C" void AvxSfpArithmetic_(double a, double b, double results[8]);

int _tmain(int argc, _TCHAR* argv[])
{
    const int n = 8;
    const char* inames[n] =
    {
        "vaddsd", "vsubsd", "vmulsd", "vdivsd",
        "vminsd", "vmaxsd", "vsqrtsd a", "fabs b"
    };

    double a = 17.75;
    double b = -39.1875;
    double c[n];

    AvxSfpArithmetic_(a, b, c);

    printf("\nResults for AvxScalarFloatingPointArithmetic\n");
    printf("a:          %.6lf\n", a);
    printf("b:          %.6lf\n", b);
    for (int i = 0; i < n; i++)
        printf("%-14s %-12.6lf\n", inames[i], c[i]);

    return 0;
}

```

Listing 13-2. AvxScalarFloatingPointArithmetic_.asm

```

.model flat,c
.const
AbsMask qword 7fffffffffffffffh, 7fffffffffffffffh
.code

; extern "C" void AvxSfpArithmetic_(double a, double b, double results[8]);
;
; Description: The following function demonstrates how to use basic
;              scalar DFP arithmetic instructions.
;
; Requires:    AVX

AvxSfpArithmetic_ proc
    push ebp
    mov ebp,esp

```



```

; Load argument values
    mov  eax,[ebp+24]           ;eax = ptr to results array
    vmovsd xmm0,real8 ptr [ebp+8] ;xmm0 = a
    vmovsd xmm1,real8 ptr [ebp+16] ;xmm1 = b

; Perform basic arithmetic using AVX scalar DFP instructions
    vaddsd xmm2,xmm0,xmm1     ;xmm2 = a + b
    vsubsd xmm3,xmm0,xmm1     ;xmm3 = a - b
    vmulsd xmm4,xmm0,xmm1     ;xmm4 = a * b
    vdivsd xmm5,xmm0,xmm1     ;xmm5 = a / b
    vmovsd real8 ptr [eax+0],xmm2 ;save a + b
    vmovsd real8 ptr [eax+8],xmm3 ;save a - b
    vmovsd real8 ptr [eax+16],xmm4 ;save a * b
    vmovsd real8 ptr [eax+24],xmm5 ;save a / b

; Compute min(a, b), max(a, b), sqrt(a) and fabs(b)
    vminsd xmm2,xmm0,xmm1     ;xmm2 = min(a, b)
    vmaxsd xmm3,xmm0,xmm1     ;xmm3 = max(a, b)
    vsqrtsd xmm4,xmm0,xmm0     ;xmm4 = sqrt(a)
    vandpd xmm5,xmm1,xmmword ptr [AbsMask] ;xmm5 = fabs(b)
    vmovsd real8 ptr [eax+32],xmm2 ;save min(a, b)
    vmovsd real8 ptr [eax+40],xmm3 ;save max(a, b)
    vmovsd real8 ptr [eax+48],xmm4 ;save sqrt(a)
    vmovsd real8 ptr [eax+56],xmm5 ;save trunc(sqrt(a))

    pop  ebp
    ret
AvxSfpArithmetic_ endp
end

```

The C++ code in the `AvxScalarFloatingPointArithmetic.cpp` file (see Listing 13-1) should be clear-cut. Near the top of the file is a declaration for the assembly language function `AvxSpfArithmetic_`, which requires two double-precision floating-point parameter values and a pointer to a results array. The function `_tmain` contains code that performs basic programming tasks, including initialization of the test variables `a` and `b`. It then invokes the function `AvxSpfArithmetic_` and displays the results.

The assembly language function `AvxSfpArithmetic_` uses the x86-AVX instruction set to perform several common double-precision floating-point arithmetic operations. Following the function prolog, a `vmovsd xmm0,real8 ptr [ebp+8]` instruction loads argument value `a` into the low-order quadword of register `XMM0`. Execution of the x86-AVX instruction `vmovsd` is nearly identical to the corresponding x86-SSE instruction `movsd` with one key exception: it sets the high-order 192 bits of `YMM0` (`yymm0[255:64]`) to zero. The next instruction, `vmovsd xmm1,real8 ptr [ebp+16]`, performs a similar operation and loads argument value `b` into register `XMM1`.

Subsequent to the loading of argument values `a` and `b` into registers `XMM0` and `XMM1`, the `vaddsd xmm2,xmm0,xmm1` instruction adds the scalar double-precision floating-point values in `XMM0` and `XMM1`, and saves the result to the low-order

quadword of XMM2. Unlike its x86-SSE counterpart instruction, `vaddsd` executes two ancillary operations. It copies the upper quadword of register XMM0 to the upper quadword of XMM2 (`xmm2[127:64] = xmm0[127:64]`) and sets the high-order 128 bits of YMM2 (`ymm2[255:128]`) to zero.

The next three instructions—`vsubsd`, `vmulsd`, and `vdivsd`—carry out scalar double-precision floating-point subtraction, multiplication, and division, respectively. These instructions also perform the previously described secondary operations on their corresponding destination operands. Following execution of the four basic arithmetic instructions, the outcomes are saved to the `results` array using a series of `vmovsd` instructions. Note that when the `vmovsd` instruction is used with a memory destination operand, only the low-order quadword of the source operand is copied to memory. No additional quadword data transfers or bit zeroing operations are performed.

The next code block illustrates use of the `vminsd`, `vmaxsd`, and `vsqrtsd` instructions. It also demonstrates use of the `vandpd` instruction to compute the absolute value of a scalar double-precision floating-point value. The `vminsd xmm2, xmm0, xmm1` and `vmaxsd xmm3, xmm0, xmm1` instructions compute $\min(a, b)$ and $\max(a, b)$, respectively. Note that the x86-AVX `vsqrtsd` instruction requires two source operands, but only computes the square root of its second source operand. These three instructions also copy the upper quadword of their first source operand the upper quadword of the destination operand and zero out the high-order 128 bits of the destination operand's corresponding YMM register.

The `vandpd xmm5, xmm1, xmmword ptr [AbsMask]` performs a logical bitwise AND of two packed double-precision floating point values and saves the result to the destination operand (there is no `vandsd` instruction). The second source operand of this instruction is defined in the `.const` section. It contains a bit pattern that clears the sign bit of both double-precision floating-point values in a 128-bit wide packed operand. The `vandpd` instruction that's used here also sets the bits `ymm5[255:128]` to zero.

You may have already noticed that the `AvxSpfArithmetic_function` lacks any register-to-register data transfer instructions. This is an intended consequence of the three-operand syntax that's employed by x86-AVX. A similarly-coded x86-SSE function would have required several additional register-to-register or memory-to-register `movsd` instructions. Output 13-1 shows the results for sample program `AvxScalarFloatingPointArithmetic`.

Output 13-1. Sample Program `AvxScalarFloatingPointArithmetic`

```
Results for AvxScalarFloatingPointArithmetic
a:                17.750000
b:                -39.187500
vaddsd            -21.437500
vsubsd           56.937500
vmulsd           -695.578125
vdivsd           -0.452951
vminsd           -39.187500
vmaxsd           17.750000
vsqrtsd a        4.213075
fabs b           39.187500
```

Scalar Floating-Point Compares

The x86-AVX instruction set supports several different instructions for performing scalar floating-point compares. The `vcomisd` and `vcomiss` instructions set status bits in the EFLAGS register to indicate the results of a compare operation. In Chapter 8, you reviewed a sample program that used the x86-SSE equivalent instructions `comisd` and `comiss` to perform scalar floating-point compares. In this section, you examine a sample program named `AvxScalarFloatingPointCompare`, which illustrates how to compare two scalar double-precision floating-point values using the x86-AVX `vcmps`d (Compare Scalar Double-Precision Floating-Point Values) instruction. The C++ and assembly language source code for the sample program `AvxScalarFloatingPointCompare` are shown in Listings 13-3 and 13-4, respectively.

Listing 13-3. `AvxScalarFloatingPointCompare.cpp`

```
#include "stdafx.h"
#include <limits>

using namespace std;

extern "C" void AvxSfpCompare_(double a, double b, bool results[8]);

int _tmain(int argc, _TCHAR* argv[])
{
    const int n = 4;
    const int m = 8;

    const char* inames[8] =
    {
        "vcmpesd", "vcmpesqsd", "vcmpltsd", "vcmplesd",
        "vcmpgtsd", "vcmpgesd", "vcmpordsd", "vcmpunordsd"
    };

    double a[n] = { 20.0, 50.0, 75.0, 42.0 };
    double b[n] = { 30.0, 40.0, 75.0, 0.0 };
    bool results[n][m];

    b[3] = numeric_limits<double>::quiet_NaN();

    printf("Results for AvxScalarFloatingPointCompare\n");

    for (int i = 0; i < n; i++)
    {
        AvxSfpCompare_(a[i], b[i], results[i]);

        printf("\na: %8lf b: %8lf\n", a[i], b[i]);
    }
}
```

```

    for (int j = 0; j < m; j++)
        printf("%12s = %d\n", inames[j], results[i][j]);
}

return 0;
}

```

Listing 13-4. AvxScalarFloatingPointCompare_.asm

```

.model flat,c
.code

; extern "C" void AvxSfpCompare_(double a, double b, bool results[8]);
;
; Description: The following function demonstrates use of the
;             x86-AVX compare instruction vcmpsd.
;
; Requires:   AVX

AvxSfpCompare_ proc
    push ebp
    mov ebp,esp

; Load argument values
    vmovsd xmm0,real8 ptr [ebp+8]           ;xmm0 = a
    vmovsd xmm1,real8 ptr [ebp+16]        ;xmm1 = b;
    mov eax,[ebp+24]                       ;eax = ptr to results array

; Perform compare for equality
    vcmpeqsd xmm2,xmm0,xmm1               ;perform compare operation
    vmovmskpd ecx,xmm2                    ;move result to bit 0 of ecx
    test ecx,1                             ;test bit result
    setnz byte ptr [eax+0]                 ;save result as C++ bool

; Perform compare for inequality. Note that vcmpneqsd returns true
; if used with QNaN or SNaN operand values.
    vcmpneqsd xmm2,xmm0,xmm1
    vmovmskpd ecx,xmm2
    test ecx,1
    setnz byte ptr [eax+1]

; Perform compare for less than
    vcmpltssd xmm2,xmm0,xmm1
    vmovmskpd ecx,xmm2
    test ecx,1
    setnz byte ptr [eax+2]

```

```

; Perform compare for less than or equal
    vcmplsd xmm2,xmm0,xmm1
    vmovmskpd ecx,xmm2
    test ecx,1
    setnz byte ptr [eax+3]

; Perform compare for greater than
    vcmpltgd xmm2,xmm0,xmm1
    vmovmskpd ecx,xmm2
    test ecx,1
    setnz byte ptr [eax+4]

; Perform compare for greater than or equal
    vcmplgsd xmm2,xmm0,xmm1
    vmovmskpd ecx,xmm2
    test ecx,1
    setnz byte ptr [eax+5]

; Perform compare for ordered
    vcmpordsd xmm2,xmm0,xmm1
    vmovmskpd ecx,xmm2
    test ecx,1
    setnz byte ptr [eax+6]

; Perform compare for unordered
    vcmpunordsd xmm2,xmm0,xmm1
    vmovmskpd ecx,xmm2
    test ecx,1
    setnz byte ptr [eax+7]

    pop ebp
    ret
AvxSfpCompare_ endp
end

```

The `_tmain` function in `AvxScalarFloatingPointCompare.cpp` (see Listing 13-3) contains some elementary C++ statements that exercise the assembly language function `AvxSfpCompare_` using different test values. Note that the last entry of the double-precision floating-point array `b` is assigned a value of `QNaN`. (`QNaN` values are discussed in Chapter 3.) This assignment is performed in order to demonstrate an unordered floating-point compare operation. For each pair of test values, the function `_tmain` displays the results of eight distinct double-precision floating-point compare operations.

Before examining the assembly language source code, you need to learn a few details about the `vcmpsd` instruction. The comments that follow also apply to the `vcmpss` (Compare Scalar Single-Precision Floating-Point Values) instruction. These instructions support two different assembly language syntax formats. The first format requires four operands: a destination operand, two source operands, and an immediate operand that specifies a compare predicate. Most x86 assemblers including MASM also support a

three-operand pseudo-instruction format that incorporates the compare predicate within the instruction mnemonic.

The `vcmps` and `vcmps` instructions support 32 different compare predicates. Table 13-1 lists the most commonly-used compare predicates and their corresponding operations. Information regarding the other compare predicates may be found in the Intel and AMD instruction reference manuals listed in Appendix C. Execution of a `vcmps` (`vcmps`) instruction yields a quadword (doubleword) mask result that is saved to the destination operand. The only possible values for the mask result are all 1s (true compare) or all 0s (false compare). Figure 13-1 illustrates execution of the `vcmps` and `vcmps` instructions. In Chapter 14, you learn about the `vcmp` and `vcmps` instructions, which are the packed version equivalents of `vcmps` and `vcmps`.

Table 13-1. Common `vcmps` and `vcmps` Compare Predicates

PredOp	Predicate	Description	Pseudo-Instructions
0	EQ	Src1 == Src2	<code>vcmpeq(s d)</code>
1	LT	Src1 < Src2	<code>vcmlt(s d)</code>
2	LE	Src1 <= Src2	<code>vcmlle(s d)</code>
3	UNORD	Src1 && Src2 are unordered	<code>vcmpunord(s d)</code>
4	NEQ	Src1 != Src2	<code>vcmpneq(s d)</code>
13	GE	Src1 >= Src2	<code>vcmpge(s d)</code>
14	GT	Src1 > Src2	<code>vcmpgt(s d)</code>
7	ORD	Src1 && Src2 are ordered	<code>vcmpord(s d)</code>

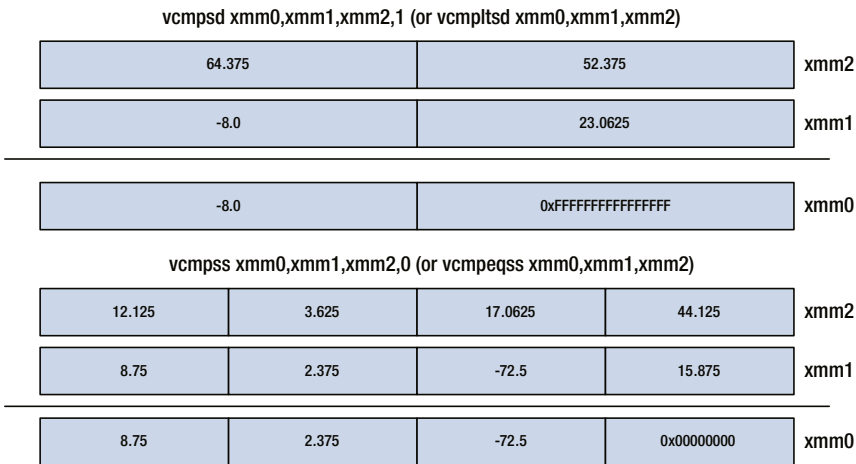

Note: In both of the above examples, `ymm0[255:128]` is set to all 0s.

Figure 13-1. Execution of the `vcmps` and `vcmps` instructions

Following its prolog, the function `AvxSfpCompare_` (see Listing 13-4) loads argument values `a` and `b` into registers `XMM0` and `XMM1`, respectively, using two `vmovsd` instructions. It then initializes a pointer to the array `results`. The `vcmpqsd xmm2, xmm0, xmm1` instruction compares `a` and `b` for equality; it then saves the resultant mask value to the low-order quadword of `XMM2`. This instruction also performs the same ancillary operations that you learned about in the previous section. More specifically, all `vcmps` (`vcmpss`) instructions copy the upper 64 (96) bits of the first source operand to corresponding positions in the destination operand. They also zero the high-order 128 bits of the destination operand's corresponding `YMM` register.

The next instruction, `vmovmskpd ecx, xmm2`, copies the sign bits of each double-precision floating-point value in the source operand to the low-order bits of the destination operand (the unused high-order bits of the destination operand are set to zero). In the current example, the low-order quadword of `XMM2` contains the result of the `vcmpqsd` compare operation, which is either all 0s or all 1s. The high-order quadword of `XMM2` is a “don't care” value. Use of the `vmovmskpd` instruction sets bit zero of register `ECX` according to the result of the compare. The `test ecx, 1` and `setnz byte ptr [eax+0]` instructions save the compare result to the `results` array.

The remaining compare operations are performed using the same sequence of instructions, except for the specific compare instruction. Note that unlike the x86-SSE `cmpsd` and `cmpss` instructions, the `vcmps` and `vcmpss` instructions explicitly support the compare predicates `GT` and `GE`. Also note that the `vcmpneqsd` instruction returns a value of true if a QNaN or SNaN operand is used. You may be asking yourself, given a choice between the `vcmps`/`vcmpss` and `vcomisd`/`vcomiss` instructions, which variation should be used? The latter two instructions are simpler to use, but only support a small set of compare operations. Besides supporting an extensive set of compare predicates, the former set of instructions is useful if you need a bit mask to perform subsequent Boolean operations. Output 13-2 shows the results for sample program `AvxScalarFloatingPointCompare`.

Output 13-2. Sample Program `AvxScalarFloatingPointCompare`

Results for `AvxScalarFloatingPointCompare`

```
a: 20.000000 b: 30.000000
```

```
vcmpqsd = 0
vcmpneqsd = 1
vcmpltsd = 1
vcmplesd = 1
vcmpgtsd = 0
vcmpgesd = 0
vcmpordsd = 1
vcmpunordsd = 0
```

```
a: 50.000000 b: 40.000000
```

```
vcmpqsd = 0
vcmpneqsd = 1
vcmpltsd = 0
vcmplesd = 0
```

```

vcmpgtsd = 1
vcmpgesd = 1
vcmpordsd = 1
vcmpunordsd = 0

```

```
a: 75.000000 b: 75.000000
```

```

vcmpesqd = 1
vcmpneqsd = 0
vcmpltsd = 0
vcmplesd = 1
vcmpgtsd = 0
vcmpgesd = 1
vcmpordsd = 1
vcmpunordsd = 0

```

```
a: 42.000000 b: 1.#QNANO
```

```

vcmpesqd = 0
vcmpneqsd = 1
vcmpltsd = 0
vcmplesd = 0
vcmpgtsd = 0
vcmpgesd = 0
vcmpordsd = 0
vcmpunordsd = 1

```

Advanced Programming

In this section, you learn how to use the x86-AVX instruction set to perform advanced scalar floating-point computations. The first sample program illustrates how to calculate the roots of a quadratic equation. The second sample program uses the scalar floating-point capabilities of x86-AVX to carry out spherical coordinate conversions. This sample program also demonstrates using standard C++ library functions from an assembly language function that uses x86-AVX instructions. Both sample programs also emphasize the computational advantages and simplified programming of using x86-AVX versus x86-SSE.

Roots of a Quadratic Equation

The next sample program, named `AvxScalarFloatingPointQuadEq`, demonstrates using the x86-AVX instruction set to compute the roots of a quadratic equation. It also provides additional examples of how to use the x86-AVX scalar floating-point arithmetic instructions. Listings 13-5 and 13-6 contain the C++ and x86-AVX assembly language code for `AvxScalarFloatingPointQuadEq`.

Listing 13-5. AvxScalarFloatingPointQuadEqu.cpp

```

#include "stdafx.h"
#include <math.h>

extern "C" void AvxSfpQuadEqu_(const double coef[3], double roots[2],
double epsilon, int* dis);

void AvxSfpQuadEquCpp(const double coef[3], double roots[2], double
epsilon, int* dis)
{
    double a = coef[0];
    double b = coef[1];
    double c = coef[2];
    double delta = b * b - 4.0 * a * c;
    double temp = 2.0 * a;

    if (fabs(a) < epsilon)
    {
        *dis = 9999;
        return;
    }

    if (fabs(delta) < epsilon)
    {
        roots[0] = -b / temp;
        roots[1] = -b / temp;
        *dis = 0;
    }
    else if (delta > 0)
    {
        roots[0] = (-b + sqrt(delta)) / temp;
        roots[1] = (-b - sqrt(delta)) / temp;
        *dis = 1;
    }
    else
    {
        // roots[0] contains real part, roots[1] contains imaginary part
        // complete answer is (r0, +r1), (r0, -r1)
        roots[0] = -b / temp;
        roots[1] = sqrt(-delta) / temp;
        *dis = -1;
    }
}

```

```

int _tmain(int argc, _TCHAR* argv[])
{
    const int n = 4;
    const double coef[n * 3] =
    {
        2.0, 8.0, -15.0,      // real roots (b * b > 4 * a * c)
        1.0, 6.0, 9.0,      // identical roots (b * b = 4 * a * c)
        3.0, 2.0, 4.0,      // complex roots (b * b < 4 * a * c)
        1.0e-13, 7.0, -5.0, // invalid value for a
    };

    const double epsilon = 1.0e-12;

    printf("Results for AvxScalarFloatingPointQuadEqu\n");

    for (int i = 0; i < n * 3; i += 3)
    {
        double roots1[2], roots2[2];
        const double* coef2 = &coef[i];
        int dis1, dis2;

        AvxSfpQuadEquCpp(coef2, roots1, epsilon, &dis1);
        AvxSfpQuadEqu_(coef2, roots2, epsilon, &dis2);

        printf("\na: %lf, b: %lf c: %lf\n", coef2[0], coef2[1], coef2[2]);

        if (dis1 != dis2)
        {
            printf("Discriminant compare error\n");
            printf("dis1/dis2: %d/%d\n", dis1, dis2);
        }

        switch (dis1)
        {
            case 1:
                printf("Distinct real roots\n");
                printf("C++ roots: %lf %lf\n", roots1[0], roots1[1]);
                printf("AVX roots: %lf %lf\n", roots2[0], roots2[1]);
                break;

            case 0:
                printf("Identical roots\n");
                printf("C++ root: %lf\n", roots1[0]);
                printf("AVX root: %lf\n", roots2[0]);
                break;
        }
    }
}

```

```

    case -1:
        printf("Complex roots\n");
        printf("C++ roots: (%lf %lf) ", roots1[0], roots1[1]);
        printf("(%lf %lf)\n", roots1[0], -roots1[1]);
        printf("AVX roots: (%lf %lf) ", roots2[0], roots2[1]);
        printf("(%lf %lf)\n", roots2[0], -roots2[1]);
        break;

    case 9999:
        printf("Coefficient 'a' is invalid\n");
        break;

    default:
        printf("Invalid discriminant value: %d\n", dis1);
        return 1;
}
}

return 0;
}

```

Listing 13-6. AvxScalarFloatingPointQuadEqu.asm

```

.model flat,c
.const
FpNegateMask    qword 8000000000000000h,0    ;mask to negate DFPF value
FpAbsMask       qword 7FFFFFFFFFFFFFFFh,-1   ;mask to compute fabs()
r8_0p0          real8 0.0
r8_2p0          real8 2.0
r8_4p0          real8 4.0
.code

; extern "C" void AvxSfpQuadEqu_(const double coef[3], double roots[2],
double epsilon, int* dis);
;
; Description: The following function calculates the roots of a
;              quadratic equation using the quadratic formula.
;
; Requires:    AVX

AvxSfpQuadEqu_ proc
    push ebp
    mov ebp,esp

```

```

; Load argument values
mov eax,[ebp+8]           ;eax = ptr to coeff array
mov ecx,[ebp+12]         ;ecx = ptr to roots array
mov edx,[ebp+24]         ;edx = ptr to dis
vmovsd xmm0,real8 ptr [eax] ;xmm0 = a
vmovsd xmm1,real8 ptr [eax+8] ;xmm1 = b
vmovsd xmm2,real8 ptr [eax+16] ;xmm2 = c
vmovsd xmm7,real8 ptr [ebp+16] ;xmm7 = epsilon

; Make sure coefficient a is valid
vandpd xmm6,xmm0,[FpAbsMask] ;xmm2 = fabs(a)
vcomisd xmm6,xmm7
jb Error                  ;jump if fabs(a) < epsilon

; Compute intermediate values
vmulsd xmm3,xmm1,xmm1     ;xmm3 = b * b
vmulsd xmm4,xmm0,[r8_4p0] ;xmm4 = 4 * a
vmulsd xmm4,xmm4,xmm2     ;xmm4 = 4 * a * c
vsubsd xmm3,xmm3,xmm4     ;xmm3 = b * b - 4 * a * c
vmulsd xmm0,xmm0,[r8_2p0] ;xmm0 = 2 * a
vxorpd xmm1,xmm1,[FpNegateMask] ;xmm1 = -b

; Test delta to determine root type
vandpd xmm2,xmm3,[FpAbsMask] ;xmm2 = fabs(delta)
vcomisd xmm2,xmm7
jb IdenticalRoots        ;jump if fabs(delta) < epsilon
vcomisd xmm3,[r8_0p0]
jb ComplexRoots          ;jump if delta < 0.0

; Distinct real roots
; r1 = (-b + sqrt(delta)) / 2 * a, r2 = (-b - sqrt(delta)) / 2 * a
vsqrtsd xmm3,xmm3,xmm3    ;xmm3 = sqrt(delta)
vaddsd xmm4,xmm1,xmm3     ;xmm4 = -b + sqrt(delta)
vsubsd xmm5,xmm1,xmm3     ;xmm5 = -b - sqrt(delta)
vdivsd xmm4,xmm4,xmm0     ;xmm4 = final r1
vdivsd xmm5,xmm5,xmm0     ;xmm5 = final r2
vmovsd real8 ptr [ecx],xmm4 ;save r1
vmovsd real8 ptr [ecx+8],xmm5 ;save r2
mov dword ptr [edx],1     ;*dis = 1
jmp done

; Identical roots
; r1 = r2 = -b / 2 * a
IdenticalRoots:
vdivsd xmm4,xmm1,xmm0     ;xmm4 = -b / 2 * a
vmovsd real8 ptr [ecx],xmm4 ;save r1
vmovsd real8 ptr [ecx+8],xmm4 ;save r2
mov dword ptr [edx],0     ;*dis = 0
jmp done

```

```

; Complex roots
; real = -b / 2 * a, imag = sqrt(-delta) / 2 * a
; final roots: r1 = (real, imag), r2 = (real, -imag)
ComplexRoots:
    vdivsd xmm4,xmm1,xmm0                ;xmm4 = -b / 2 * a
    vxorpd xmm3,xmm3,[FpNegateMask]     ;xmm3 = -delta
    vsqrtsd xmm3,xmm3,xmm3              ;xmm3 = sqrt(-delta)
    vdivsd xmm5,xmm3,xmm0                ;xmm5 = sqrt(-delta) / 2 * a
    vmovsd real8 ptr [ecx],xmm4         ;save real part
    vmovsd real8 ptr [ecx+8],xmm5       ;save imaginary part
    mov dword ptr [edx],-1               ;*dis = -1

Done:   pop ebp
        ret

Error:  mov dword ptr [edx],9999        ;*dis = 9999 (error code)
        pop ebp
        ret
AvxSfpQuadEqu_ endp
        end

```

A quadratic equation is a polynomial of the form $ax^2 + bx + c = 0$. In this equation, x is an unknown variable; a , b , and c are constant coefficients; and coefficient a must not be equal to zero. A quadratic equation always has two solutions for the variable x , which are called roots. The roots of a quadratic equation can be calculated using the well-known quadratic formula:

$$x = \frac{-b \pm \sqrt{b^2 - 4ac}}{2a}$$

A solution to the quadratic formula can take one of three forms, depending on the values of a , b , and c . Table 13-2 outlines these forms. The sample program `AvxScalarFloatingPointQuadEqu` uses the quadratic formula and the discriminant expressions shown in Table 13-2 to calculate the roots of a quadratic equation.

Table 13-2. Solution Forms for a Quadratic Equation

Discriminant	Root Type	Description
$b^2 - 4ac > 0$	Distinct real	root1 and root2 are different
$b^2 - 4ac = 0$	Identical real	root1 and root2 are the same
$b^2 - 4ac < 0$	Complex	root1 and root2 are different

■ **Caution** The algorithm employed in this section to calculate the roots of a quadratic equation is intended to illustrate use of the x86-AVX instruction set. You should consult the references listed in Appendix C for additional information regarding the drawbacks of using the quadratic formula to compute the roots of a quadratic equation.

The C++ code for sample program `AvxScalarFloatingPointQuadEq` (see Listing 13-5) contains a function named `AvxSfpQuadEqCpp` that computes the roots of a quadratic equation. This function mimics the method that is used by the assembly language function `AvxSfpQuadEq_` and provides a means to confirm its results. The `_tmain` function includes statements that perform test case initialization, result comparisons, and output display.

Toward top of the x86-AVX assembly language function `AvxSfpQuadEq_` (see Listing 13-6), three `vmovsd` instructions load the coefficients `a`, `b`, and `c` into registers `XMM0`, `XMM1`, and `XMM2`, respectively. Another `vmovsd` instruction loads the argument value `epsilon` into register `XMM7`. Before attempting to calculate the roots, the function `AvxSfpQuadEq_` must verify that the coefficient `a` is not equal to zero. When working with floating-point numbers, it is generally not good programming practice to carry out equality compares using constant values since the limitations of floating-point arithmetic can cause such compares to fail catastrophically. Instead, the function tests the value of coefficient `a` to determine if it's near zero. This is accomplished using the `vandpd xmm6,xmm0,[FpAbsMask]` and `vcomisd xmm6,xmm7` instructions, which evaluate whether or not $\text{fabs}(a) < \text{epsilon}$ is true. If the relational expression is true, the value of coefficient `a` is considered invalid and the function terminates.

Following the validation of coefficient `a`, the function `AvxSfpQuadEq_` calculates several intermediate values, including the discriminant value $\text{delta} = b * b - 4 * a * c$. If relational expression $\text{fabs}(\text{delta}) < \text{epsilon}$ is true, `delta` is deemed equal zero and a conditional jump is used to handle the case of identical real roots. If $\text{delta} < 0$ is true, another conditional jump is employed to process the complex root case. The fall-through condition occurs if $\text{delta} > 0$ is true, which means that there are two distinct real roots.

Table 13-3 summarizes the equations used by function `AvsSfpQuadEq_` to calculate the required roots. These calculations are carried out using the previously computed intermediate values and the x86-AVX scalar double-precision floating-point arithmetic instructions `vsqrtsd`, `vaddsd`, `vsubsd`, and `vdivsd`. The function also sets `dis` as follows: +1 (distinct real roots), 0 (identical roots), -1 (complex roots), or 9999 (coefficient `a` is invalid). This informs the caller of the root type and facilitates further processing of the results.

Table 13-3. Root Computation Equations

Case	Root Computation Equations
Distinct real roots	$r1 = (-b + \sqrt{\text{delta}}) / 2 * a$ $r2 = (-b - \sqrt{\text{delta}}) / 2 * a$
Identical real roots	$r1 = -b / 2 * a$ $r2 = -b / 2 * a$
Complex roots	$\text{real} = -b / 2 * a; \text{imag} = \sqrt{-\text{delta}} / 2 * a$ $r1 = (\text{real}, \text{imag})$ $r2 = (\text{real}, -\text{imag})$

You may have noticed again that the function `AvxSfpQuadEqu_` does not perform any register-to-register data transfers using the `vmovsd` instruction. This is direct consequence of x86-AVX's three-operand syntax. Output 13-3 shows the results for sample program `AvxScalarFloatingPointQuadEqu`.

Output 13-3. Sample Program `AvxScalarFloatingQuadEqu`

Results for `AvxScalarFloatingPointQuadEqu`

a: 2.000000, b: 8.000000 c: -15.000000

Distinct real roots

 C++ roots: 1.391165 -5.391165

 AVX roots: 1.391165 -5.391165

a: 1.000000, b: 6.000000 c: 9.000000

Identical roots

 C++ root: -3.000000

 AVX root: -3.000000

a: 3.000000, b: 2.000000 c: 4.000000

Complex roots

 C++ roots: (-0.333333 1.105542) (-0.333333 -1.105542)

 AVX roots: (-0.333333 1.105542) (-0.333333 -1.105542)

a: 0.000000, b: 7.000000 c: -5.000000

Coefficient 'a' is invalid

Spherical Coordinates

The final x86-AVX scalar floating-point sample program of this section is called `AvxScalarFloatingPointSpherical`. This program contains a couple of assembly language functions that convert a three-dimensional coordinate from rectangular to spherical units and vice versa. It also illustrates how to invoke a standard library function from a function that makes use of the x86-AVX instruction set. Listings 13-7 and 13-8 contain the C++ and assembly language source code, respectively, for sample program `AvxScalarFloatingPointSpherical`.

Listing 13-7. `AvxScalarFloatingPointSpherical.cpp`

```
#include "stdafx.h"
#include <float.h>
#define _USE_MATH_DEFINES
#include <math.h>

extern "C" bool RectToSpherical_(const double r_coord[3], double
s_coord[3]);
extern "C" bool SphericalToRect_(const double s_coord[3], double
r_coord[3]);

extern "C" double DegToRad = M_PI / 180.0;
extern "C" double RadToDeg = 180.0 / M_PI;

void PrintCoord(const char* s, const double c[3])
{
    printf("%s %14.8lf %14.8lf %14.8lf\n", s, c[0], c[1], c[2]);
}

int _tmain(int argc, _TCHAR* argv[])
{
    const int n = 7;

    const double r_coords[n * 3] =
    {
//      x coord      y coord      z coord
        2.0,          3.0,          6.0,
        -2.0,         -2.0,          2.0 * M_SQRT2,
        0.0,          M_SQRT2 / 2.0,  -M_SQRT2 / 2.0,
        M_SQRT2,      1.0,          -1.0,
        0.0,          0.0,          M_SQRT2,
        -1.0,         0.0,          0.0,
        0.0,          0.0,          0.0,
    };
};
```



```

printf("Results for AvxScalarFloatingPointSpherical\n\n");

for (int i = 0; i < n; i++)
{
    double r_coord1[3], s_coord1[3], r_coord2[3];

    r_coord1[0] = r_coords[i * 3];
    r_coord1[1] = r_coords[i * 3 + 1];
    r_coord1[2] = r_coords[i * 3 + 2];

    RectToSpherical_(r_coord1, s_coord1);
    SphericalToRect_(s_coord1, r_coord2);

    PrintCoord("r_coord1 (x,y,z): ", r_coord1);
    PrintCoord("s_coord1 (r,t,p): ", s_coord1);
    PrintCoord("r_coord2 (x,y,z): ", r_coord2);
    printf("\n");
}

return 0;
}

```

Listing 13-8. AvxScalarFloatingPointSpherical_.asm

```

.model flat,c
.const
Epsilon      real8 1.0e-15
r8_op0      real8 0.0
r8_90p0     real8 90.0

.code
extern DegToRad:real8, RadToDeg:real8
extern sin:proc, cos:proc, acos:proc, atan2:proc

; extern "C" bool RectToSpherical_(const double r_coord[3], double
s_coord[3]);
;
; Description: The following function performs rectangular to
;              spherical coordinate conversion.
;
; Requires: AVX

RectToSpherical_ proc
    push ebp
    mov ebp,esp
    push esi
    push edi
    sub esp,16                                ;space for acos & atan2 args

```

```

; Load argument values
    mov esi,[ebp+8]           ;esi = ptr to r_coord
    mov edi,[ebp+12]        ;edi = ptr to s_coord
    vmovsd xmm0,real8 ptr [esi] ;xmm0 = x coord
    vmovsd xmm1,real8 ptr [esi+8] ;xmm1 = y coord
    vmovsd xmm2,real8 ptr [esi+16] ;xmm2 = z coord

; Compute r = sqrt(x * x + y * y + z * z)
    vmulsd xmm3,xmm0,xmm0    ;xmm3 = x * x
    vmulsd xmm4,xmm1,xmm1    ;xmm4 = y * y
    vmulsd xmm5,xmm2,xmm2    ;xmm5 = z * z
    vaddsd xmm6,xmm3,xmm4
    vaddsd xmm6,xmm6,xmm5
    vsqrtsd xmm7,xmm7,xmm6    ;xmm7 = r

; Compute phi = acos(z / r)
    vcomisd xmm7,real8 ptr [Epsilon]
    jae LB1                 ;jump if r >= epsilon
    vmovsd xmm4,real8 ptr [r8_0p0] ;round r to 0.0
    vmovsd real8 ptr [edi],xmm4    ;save r
    vmovsd xmm4,real8 ptr [r8_90p0] ;phi = 90.0 degrees
    vmovsd real8 ptr [edi+16],xmm4 ;save phi
    jmp LB2

LB1:    vmovsd real8 ptr [edi],xmm7    ;save r
        vdivsd xmm4,xmm2,xmm7        ;xmm4 = z / r
        vmovsd real8 ptr [esp],xmm4    ;save on stack
        call acos
        fmul real8 ptr [RadToDeg]      ;convert phi to degrees
        fstp real8 ptr [edi+16]       ;save phi

; Compute theta = atan2(y, x)
LB2:    vmovsd xmm0,real8 ptr [esi]    ;xmm0 = x
        vmovsd xmm1,real8 ptr [esi+8] ;xmm1 = y
        vmovsd real8 ptr [esp+8],xmm0
        vmovsd real8 ptr [esp],xmm1
        call atan2
        fmul real8 ptr [RadToDeg]      ;convert theta to degrees
        fstp real8 ptr [edi+8]       ;save theta

        add esp,16
        pop edi
        pop esi
        pop ebp
        ret
RectToSpherical_ endp

```

```

; extern "C" bool SphericalToRect(const double s_coord[3], double
r_coord[3]);
;
; Description: The following function performs spherical to
;             rectangular coordinate conversion.
;
; Requires: AVX
;
; Local stack variables
;   ebp-8   sin(theta)
;   ebp-16  cos(theta)
;   ebp-24  sin(phi)
;   ebp-32  cos(phi)

SphericalToRect_proc
    push ebp
    mov  ebp,esp
    sub  esp,32                ;local variable space
    push esi
    push edi
    sub  esp,8                ;space for sin & cos argument

; Load argument values
    mov  esi,[ebp+8]          ;esi = ptr to s_coord
    mov  edi,[ebp+12]        ;edi = ptr to r_coord

; Compute sin(theta) and cos(theta)
    vmovsd xmm0,real8 ptr [esi+8]    ;xmm0 = theta
    vmulsd xmm1,xmm0,real8 ptr [DegToRad] ;xmm1 = theta in radians
    vmovsd real8 ptr [ebp-16],xmm1    ;save theta for later use
    vmovsd real8 ptr [esp],xmm1
    call sin
    fstp real8 ptr [ebp-8]            ;save sin(theta)
    vmovsd xmm1,real8 ptr [ebp-16]    ;xmm1 = theta in radians
    vmovsd real8 ptr [esp],xmm1
    call cos
    fstp real8 ptr [ebp-16]          ;save cos(theta)

; Compute sin(phi) and cos(phi)
    vmovsd xmm0,real8 ptr [esi+16]   ;xmm0 = phi
    vmulsd xmm1,xmm0,real8 ptr [DegToRad] ;xmm1 = phi in radians
    vmovsd real8 ptr [ebp-32],xmm1    ;save phi for later use
    vmovsd real8 ptr [esp],xmm1
    call sin

```

```

    fstp real8 ptr [ebp-24]           ;save sin(phi)
    vmovsd xmm1,real8 ptr [ebp-32]   ;xmm1 = phi in radians
    vmovsd real8 ptr [esp],xmm1
    call cos
    fstp real8 ptr [ebp-32]         ;save cos(phi)

; Compute x = r * sin(phi) * cos(theta)
    vmovsd xmm0,real8 ptr [esi]      ;xmm0 = r
    vmulsd xmm1,xmm0,real8 ptr [ebp-24] ;xmm1 = r * sin(phi)
    vmulsd xmm2,xmm1,real8 ptr [ebp-16] ;xmm2 = r*sin(phi)*cos(theta)
    vmovsd real8 ptr [edi],xmm2      ;save x

; Compute y = r * sin(phi) * sin(theta)
    vmulsd xmm2,xmm1,real8 ptr [ebp-8] ;xmm2 = r*sin(phi)*sin(theta)
    vmovsd real8 ptr [edi+8],xmm2     ;save y

; Compute z = r * cos(phi)
    vmulsd xmm1,xmm0,real8 ptr [ebp-32] ;xmm1 = r * cos(phi)
    vmovsd real8 ptr [edi+16],xmm1     ;save z

    add esp,8
    pop edi
    pop esi
    mov esp,ebp
    pop ebp
    ret
SphericalToRect_ endp
end

```

Before examining the source code, let's quickly review the basics of a three-dimensional coordinate system. A point in three-dimensional space can be uniquely specified using an ordered tuple (x , y , and z). The values for x , y , and z represent signed distances from an origin point, which is located at the intersection of two perpendicular planes. The ordered tuple (x , y , and z) is called a rectangular or Cartesian coordinate. A point in three-dimensional space also can be uniquely specified using a radius vector r , angle θ , and angle φ , as illustrated in Figure 13-2. An ordered tuple (r , θ , and φ) is called a spherical coordinate.

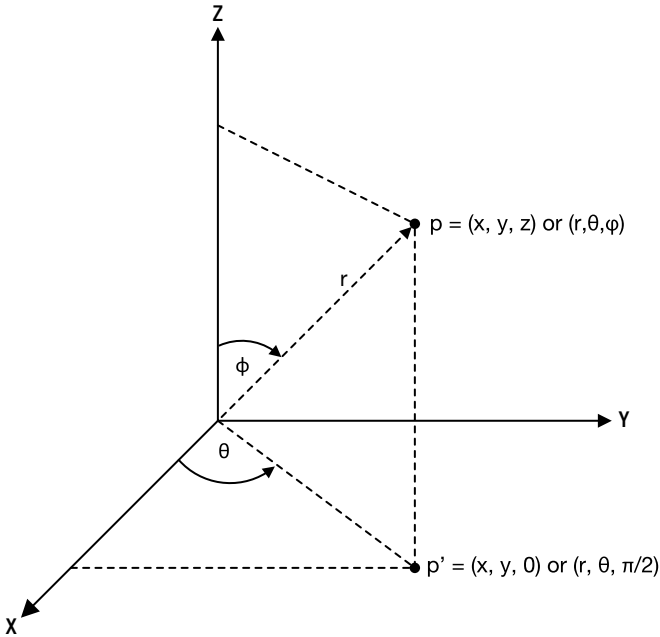

Figure 13-2. Specification of a point using rectangular and spherical coordinates

A point in three-dimensional space can be converted from rectangular to spherical coordinates and vice versa using the following formulas:

$$\begin{aligned}
 r &= \sqrt{x^2 + y^2 + z^2}, & r &\geq 0 \\
 \theta &= \tan^{-1}(y/x), & -\pi &\leq \theta \leq \pi \\
 \phi &= \cos^{-1}(z/r), & 0 &\leq \phi \leq \pi \\
 x &= r \sin \phi \cos \theta, & y &= r \sin \phi \sin \theta, & z &= r \cos \phi
 \end{aligned}$$

The inverse tangent function that's used to compute θ corresponds to the C++ library function `atan2`, which uses the signs of x and y to determine the correct quadrant.

Toward the top of the `AvxScalarFloatingPointSpherical.cpp` file (see Listing 13-7) are the declaration statements for the coordinate conversion functions. Both functions use three-element double-precision floating-point arrays to represent a rectangular or spherical coordinate. Elements 0, 1, and 2 of an `r_coord` array correspond to the x , y , and z values of a rectangular coordinate. Similarly, the spherical coordinate components r , θ , and ϕ are stored in elements 0, 1, and 2 of an `s_coord` array. The `_tmain` function contains a simple `for` loop that exercises the assembly language coordinate conversion functions using different test cases and prints the results.

The `AvxScalarFloatingPointSpherical_.asm` file (see Listing 13-8) contains the assembly language code for the `RectToSpherical_` and `SphericalToRect_` functions. Following the prolog in function `RectToSpherical_`, a `sub esp,16` instruction allocates space on the stack for two double-precision floating-point numbers. This space is used to store the argument values when calling the C++ library functions `acos` and `atan2`. The rectangular coordinate values `x`, `y`, and `z` are then loaded into registers `XMM0`, `XMM1`, and `XMM2`, respectively, using a series of `vmovsd` instructions. Next, the value of `r` is calculated according to the previously-defined formula and saved to the appropriate location in `s_coord`.

Before calculating `phi`, the function `RectToSpherical_` must determine if `r` is less than `Epsilon`. If true, `r` is rounded to zero and `phi` is set to 90 degrees. Otherwise, the function `RectToSpherical_` calculates `z / r` and saves the quotient on the stack. It then calls the C++ library function `acos` to compute the inverse cosine of `z / r`. Note that according to the Visual C++ calling convention for 32-bit programs, called functions are not required to preserve the contents of the XMM registers. This means that the contents of the XMM registers are unknown following execution of `acos`.

The function `acos` stores its return value on the x87 FPU register stack. This value is converted from radians to degrees and saved in the array `s_coord`. Computation of `theta` occurs next. The argument values required by the C++ library function `atan2`, `x` and `y`, are copied onto the stack prior to the `call atan2` instruction. Upon return from `atan2`, the top of the x87 FPU stack contains `theta` in radians. This value is converted to degrees and saved to the `s_coord` array.

The `SphericalToRect_` function is a little more complicated than `RectToSpherical_` since it needs to compute several intermediate values in order to perform a spherical-to-rectangular coordinate conversion. The prolog for `SphericalToRect_` allocates 32 bytes of stack space for intermediate values, including `sin(theta)`, `cos(theta)`, `sin(phi)`, and `cos(phi)`. A `sub esp,8` instruction allocates space on the stack for a double-precision floating-point argument value. This space is used to pass an argument value to the library functions `sin` and `cos`.

Following the obligatory prolog and register initializations, the function `SphericalToRect_` computes `sin(theta)` and `cos(theta)`. Figure 13-3 shows the contents of the stack prior to the `call sin` and `call cos` instructions. Note that `theta` must be re-copied onto the stack prior to the `call cos` instruction since the library function `sin` may have altered the original value on the stack. Computation of `sin(phi)` and `cos(phi)` occurs next using the same approach. Subsequent to the calculation of the requisite angle sines and cosines, the rectangular coordinate components `x`, `y`, and `z` are computed and saved to the `r_coord` array. Output 13-4 shows the results for sample program `AvxScalarFloatingPointSpherical`.

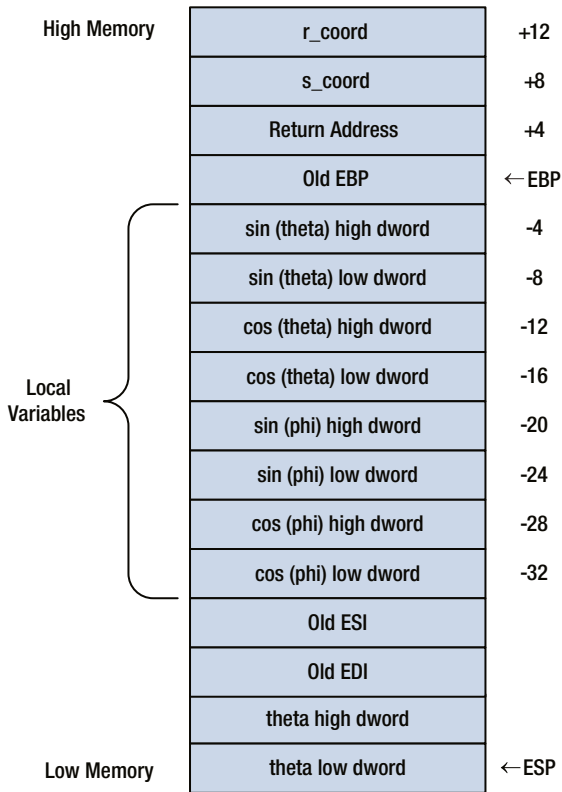

Figure 13-3. Stack contents prior to the call `sin` and call `cos` instructions

Output 13-4. Sample Program `AvxScalarFloatingPointSpherical`

Results for `AvxScalarFloatingPointSpherical`

```

r_coord1 (x,y,z):    2.00000000    3.00000000    6.00000000
s_coord1 (r,t,p):    7.00000000    56.30993247   31.00271913
r_coord2 (x,y,z):    2.00000000    3.00000000    6.00000000

r_coord1 (x,y,z):   -2.00000000   -2.00000000    2.82842712
s_coord1 (r,t,p):    4.00000000  -135.00000000  45.00000000
r_coord2 (x,y,z):   -2.00000000   -2.00000000    2.82842712

r_coord1 (x,y,z):    0.00000000    0.70710678   -0.70710678
s_coord1 (r,t,p):    1.00000000    90.00000000  135.00000000
r_coord2 (x,y,z):    0.00000000    0.70710678   -0.70710678

```

r_coord1 (x,y,z):	1.41421356	1.00000000	-1.00000000
s_coord1 (r,t,p):	2.00000000	35.26438968	120.00000000
r_coord2 (x,y,z):	1.41421356	1.00000000	-1.00000000
r_coord1 (x,y,z):	0.00000000	0.00000000	1.41421356
s_coord1 (r,t,p):	1.41421356	0.00000000	0.00000000
r_coord2 (x,y,z):	0.00000000	0.00000000	1.41421356
r_coord1 (x,y,z):	-1.00000000	0.00000000	0.00000000
s_coord1 (r,t,p):	1.00000000	180.00000000	90.00000000
r_coord2 (x,y,z):	-1.00000000	0.00000000	0.00000000
r_coord1 (x,y,z):	0.00000000	0.00000000	0.00000000
s_coord1 (r,t,p):	0.00000000	0.00000000	90.00000000
r_coord2 (x,y,z):	0.00000000	0.00000000	0.00000000

Summary

In this chapter, you learned how to perform scalar floating-point calculations using the x86-AVX instruction set. You also became familiar with some of the differences between the execution environments of x86-SSE and x86-AVX. As exemplified by the sample programs of this chapter, x86-AVX offers programmers a number of notable benefits including simplified assembly language coding and reduced register-to-register data transfers. In the next chapter, you learn about the packed floating-point capabilities of the x86-AVX instruction set.



X86-AVX Programming - Packed Floating-Point

In Chapter 9, you became familiar with the packed floating-point resources of x86-SSE. In this chapter, the packed floating-point capabilities of x86-AVX are explored. The sample programs illustrate how to perform basic packed floating-point arithmetic using 256-bit wide operands. They also exemplify use of the x86-AVX instruction set to carry out arithmetic operations using floating-point arrays and matrices. All of the sample programs in this chapter require a processor and operating system that supports AVX. As a reminder, Appendix C contains a list of several freely-available tools that you can use to ascertain whether your PC supports AVX.

Programming Fundamentals

In this section, you examine two sample programs that elucidate fundamental packed floating-point operations using the x86-AVX instruction set. The first sample program demonstrates how to perform single-precision and double-precision floating-point arithmetic using 256-bit wide packed operands. The second sample program explains packed floating-point compare operations. These programs also illustrate several important x86-AVX programming ancillaries, including operand alignment and proper use of the `vzeroupper` instruction.

Some of the sample programs in this and subsequent chapters make use of a C++ union named `YmmVal`, shown in Listing 14-1, to facilitate data exchange between C++ and assembly language functions. The items declared in this union correspond to packed data types of a 256-bit wide operand. The union `YmmVal` also contains several text string formatting function declarations. The file `YmmVal.cpp` (source code not shown) contains the definitions for the `ToString_` formatting functions and is included in the sample code subfolder `CommonFiles`.

Listing 14-1. YmmVal.h

```

#pragma once
#include "MiscDefs.h"

union YmmVal
{
    Int8 i8[32];
    Int16 i16[16];
    Int32 i32[8];
    Int64 i64[4];
    UInt8 u8[32];
    UInt16 u16[16];
    UInt32 u32[8];
    UInt64 u64[4];
    float r32[8];
    double r64[4];

    char* ToString_i8(char* s, size_t len, bool upper_half);
    char* ToString_i16(char* s, size_t len, bool upper_half);
    char* ToString_i32(char* s, size_t len, bool upper_half);
    char* ToString_i64(char* s, size_t len, bool upper_half);

    char* ToString_u8(char* s, size_t len, bool upper_half);
    char* ToString_u16(char* s, size_t len, bool upper_half);
    char* ToString_u32(char* s, size_t len, bool upper_half);
    char* ToString_u64(char* s, size_t len, bool upper_half);

    char* ToString_x8(char* s, size_t len, bool upper_half);
    char* ToString_x16(char* s, size_t len, bool upper_half);
    char* ToString_x32(char* s, size_t len, bool upper_half);
    char* ToString_x64(char* s, size_t len, bool upper_half);

    char* ToString_r32(char* s, size_t len, bool upper_half);
    char* ToString_r64(char* s, size_t len, bool upper_half);
};

```

Packed Floating-Point Arithmetic

The first sample program of this section, called `AvxPackedFloatingPointArithmetic`, demonstrates how to perform common arithmetic operations using packed 256-bit wide floating-point operands. It also illustrates proper use of the `vzeroupper` instruction, which must be used in order to avoid potential performance penalties whenever a function uses the YMM registers. Listings 14-2 and 14-3 show the C++ and assembly language source code for `AvxPackedFloatingPointArithmetic`.

Listing 14-2. AvxPackedFloatingPointArithmetic.cpp

```

#include "stdafx.h"
#include "YmmVal.h"

extern "C" void AvxPfpArithmeticFloat_(const YmmVal* a, const YmmVal* b, ←
YmmVal c[6]);
extern "C" void AvxPfpArithmeticDouble_(const YmmVal* a, const YmmVal* b, ←
YmmVal c[5]);

void AvxPfpArithmeticFloat(void)
{
    __declspec(align(32)) YmmVal a;
    __declspec(align(32)) YmmVal b;
    __declspec(align(32)) YmmVal c[6];

    a.r32[0] = 2.0f;      b.r32[0] = 12.5f;
    a.r32[1] = 3.5f;      b.r32[1] = 52.125f;
    a.r32[2] = -10.75f;   b.r32[2] = 17.5f;
    a.r32[3] = 15.0f;     b.r32[3] = 13.982f;
    a.r32[4] = -12.125f;  b.r32[4] = -4.75f;
    a.r32[5] = 3.875f;    b.r32[5] = 3.0625f;
    a.r32[6] = 2.0f;      b.r32[6] = 7.875f;
    a.r32[7] = -6.35f;    b.r32[7] = -48.1875f;

    AvxPfpArithmeticFloat_(&a, &b, c);

    printf("Results for AvxPfpArithmeticFloat()\n\n");

    printf(" i      a      b      Add      Sub      Mul      Div ←
      Abs      Neg\n");
    printf("-----\n");

    for (int i = 0; i < 8; i++)
    {
        const char* fs = "%8.3f ";

        printf("%2d ", i);
        printf(fs, a.r32[i]);
        printf(fs, b.r32[i]);
        printf(fs, c[0].r32[i]);
        printf(fs, c[1].r32[i]);
        printf(fs, c[2].r32[i]);
        printf(fs, c[3].r32[i]);
        printf(fs, c[4].r32[i]);
        printf(fs, c[5].r32[i]);
        printf("\n");
    }
}

```

```

void AvxPfpArithmeticDouble(void)
{
    __declspec(align(32)) YmmVal a;
    __declspec(align(32)) YmmVal b;
    __declspec(align(32)) YmmVal c[5];

    a.r64[0] = 12.0;    b.r64[0] = 0.875;
    a.r64[1] = 13.5;    b.r64[1] = -125.25;
    a.r64[2] = 18.75;   b.r64[2] = 72.5;
    a.r64[3] = 5.0;     b.r64[3] = -98.375;

    AvxPfpArithmeticDouble_(&a, &b, c);

    printf("\n\nResults for AvxPfpArithmeticDouble()\n\n");

    printf(" i      a      b      Min      Max      Sqrt a      HorAdd HorSub\n");
    printf("-----\n");

    for (int i = 0; i < 4; i++)
    {
        const char* fs = "%9.3lf ";

        printf("%2d ", i);
        printf(fs, a.r64[i]);
        printf(fs, b.r64[i]);
        printf(fs, c[0].r64[i]);
        printf(fs, c[1].r64[i]);
        printf(fs, c[2].r64[i]);
        printf(fs, c[3].r64[i]);
        printf(fs, c[4].r64[i]);
        printf("\n");
    }
}

int _tmain(int argc, _TCHAR* argv[])
{
    AvxPfpArithmeticFloat();
    AvxPfpArithmeticDouble();
    return 0;
}

```

Listing 14-3. AvxPackedFloatingPointArithmetic_.asm

```

.model flat,c
.const
align 16

; Mask value for packed SPFP absolute value
AbsMask dword 7fffffffh,7fffffffh,7fffffffh,7fffffffh
         dword 7fffffffh,7fffffffh,7fffffffh,7fffffffh

; Mask value for packed SPFP negation
NegMask dword 80000000h,80000000h,80000000h,80000000h
         dword 80000000h,80000000h,80000000h,80000000h
.code

; extern "C" void AvxPfpArithmeticFloat_(const YmmVal* a, const YmmVal* b,
YmmVal c[6]);
;
; Description: The following function illustrates how to use common
;             packed SPFP arithmetic instructions using the YMM
;             registers.
;
; Requires:   AVX

AvxPfpArithmeticFloat_ proc
    push ebp
    mov ebp,esp

; Load argument values. Note that the vmovaps instruction
; requires proper alignment of operands in memory.
    mov eax,[ebp+8]           ;eax = ptr to a
    mov ecx,[ebp+12]         ;ecx = ptr to b
    mov edx,[ebp+16]         ;edx = ptr to c
    vmovaps ymm0,ymmword ptr [eax] ;ymm0 = a
    vmovaps ymm1,ymmword ptr [ecx] ;ymm1 = b

; Perform packed SPFP addition, subtraction, multiplication,
; and division
    vaddps ymm2,ymm0,ymm1           ;a + b
    vmovaps ymmword ptr [edx],ymm2

    vsubps ymm3,ymm0,ymm1           ;a - b
    vmovaps ymmword ptr [edx+32],ymm3

    vmulps ymm4,ymm0,ymm1           ;a * b
    vmovaps ymmword ptr [edx+64],ymm4

```

```

    vdivps ymm5,ymm0,ymm1          ;a / b
    vmovaps ymmword ptr [edx+96],ymm5

; Compute packed SPFP absolute value
    vmovups ymm6,ymmword ptr [AbsMask]      ;ymm6 = AbsMask
    vandps ymm7,ymm0,ymm6                ;ymm7 = packed fabs
    vmovaps ymmword ptr [edx+128],ymm7

; Compute packed SPFP negation
    vxorps ymm7,ymm0,ymmword ptr [NegMask]  ;ymm7 = packed neg.
    vmovaps ymmword ptr [edx+160],ymm7

; Zero upper 128-bit of all YMM registers to avoid potential x86-AVX
; to x86-SSE transition penalties.
    vzeroupper

    pop ebp
    ret
AvxPfpArithmeticFloat_ endp

; extern "C" void AvxPfpArithmeticDouble_(const YmmVal* a, const YmmVal* b, ←
YmmVal c[5]);
;
; Description: The following function illustrates how to use common
;             packed DPFP arithmetic instructions using the YMM
;             registers.
;
; Requires:   AVX

AvxPfpArithmeticDouble_ proc
    push ebp
    mov ebp,esp

; Load argument values. Note that the vmovapd instruction
; requires proper alignment of operands in memory.
    mov eax,[ebp+8]          ;eax = ptr to a
    mov ecx,[ebp+12]        ;ecx = ptr to b
    mov edx,[ebp+16]        ;edx = ptr to c
    vmovapd ymm0,ymmword ptr [eax] ;ymm0 = a
    vmovapd ymm1,ymmword ptr [ecx] ;ymm1 = b

; Compute packed min, max and square root
    vminpd ymm2,ymm0,ymm1
    vmaxpd ymm3,ymm0,ymm1
    vsqrtpd ymm4,ymm0

```

```

; Perform horizontal addition and subtraction
    vhaddpd ymm5,ymm0,ymm1
    vhsbpd  ymm6,ymm0,ymm1

; Save the results
    vmovapd ymmword ptr [edx],ymm2
    vmovapd ymmword ptr [edx+32],ymm3
    vmovapd ymmword ptr [edx+64],ymm4
    vmovapd ymmword ptr [edx+96],ymm5
    vmovapd ymmword ptr [edx+128],ymm6

; Zero upper 128-bit of all YMM registers to avoid potential x86-AVX
; to x86-SSE transition penalties.
    vzeroupper

    pop ebp
    ret
AvxPfpArithmeticDouble_ endp
end

```

The C++ code for `AvxPackedFloatingPointArithmetic` (see Listing 14-2) contains a function named `AvxPfpArithmeticFloat`. This function begins by initializing a couple of `YmmVal` variables with single-precision floating-point test values. Note that each `YmmVal` instance is aligned to a 32-byte boundary using the Visual C++ extended attribute `__declspec(align(32))`. The `AvxPfpArithmeticFloat` function invokes an x86-AVX assembly language function named `AvxPfpArithmeticFloat_` that demonstrates common packed single-precision floating-point arithmetic operations. The results of these arithmetic operations are displayed in matrix form using a series of `printf` statements. The C++ code also includes a function named `AvxPfpArithmeticDouble`, which illustrates arithmetic operations using packed double-precision floating-point values. The logical organization of this function is the similar to its packed single-precision floating-point counterpart.

Listing 14-3 shows the x86-AVX assembly language code for the sample program `AvxPackedFloatingPointArithmetic`. Toward the top of the listing is a `.const` section that defines a 32-byte wide packed mask value named `AbsMask`, which is used to compute packed single-precision floating-point absolute values. A second packed mask called `NegMask` is defined to carry out packed single-precision floating-point negation. Note that when used in a `.const` section, the size argument of an `align` directive cannot exceed 16. This means that the packed values `AbsMask` and `NegMask` may not be properly aligned. Because of x86-AVX's relaxed alignment requirements for memory operands (discussed in Chapter 12), these values can be referenced by most x86-AVX instructions without causing a processor exception to occur. Another option is to use the `MASM` segment directive to define a constant section that permits data values to be aligned on a 32-byte boundary. You learn how to do this in Chapter 15.

Following the prolog and argument register initializations, a `vmovaps ymm0,ymmword ptr [eax]` instruction loads packed value `a` into register `YMM0`. The `vmovaps` instruction requires its memory-based source operand to be properly aligned. Next, a `vmovaps ymm1,ymmword ptr [ecx]` instruction loads packed value `b` into register `YMM1`. This is

followed by a `vaddps ymm2, ymm0, ymm1` instruction, which sums the packed single-precision floating-point values in YMM0 and YMM1 and saves the result to YMM2. The function then performs packed single-precision floating-point subtraction, multiplication, and division using the `vsubps`, `vmulps`, and `vdivps` instructions, respectively.

The next two instructions—`vmovups ymm6, ymmword ptr [AbsMask]` and `vandps ymm7, ymm0, ymm6`—compute the packed absolute value of `a`. Note that the `vmovups` instruction cannot be used to load `AbsMask` into a YMM register since it's improperly aligned. The `vxorps ymm7, ymm0, ymmword ptr [NegMask]` instruction negates the elements of `a`. It also exemplifies x86-AVX's relaxed memory alignment requirements since `NegMask` is not explicitly aligned to a 32-byte boundary. The final instruction before the epilog is `vzeroupper`, which is necessary to avoid potential performance penalties that can occur when an x86 processor transitions from executing x86-AVX to x86-SSE instructions. Chapter 12 discusses potential x86-AVX to x86-SSE state transition performance penalties in greater detail.

The `AvxPfpArithmeticDouble_` function (see Listing 14-3) illustrates use of several additional packed floating-point arithmetic operations using double-precision instead of single-precision values. The `vmnpsd`, `vmaxpd`, and `vsqrtpd` instructions compute packed double-precision minimums, maximums, and square roots, respectively. Horizontal (adjacent element) addition and subtraction are carried out using the `vhaddpd` and `vhsbpd` instructions (see Figure 7-8). The results of these operations are saved to the caller's array using a series of `vmovapd` instructions. The last instruction in function `AvxPfpArithmeticDouble_` prior to its epilog is `vzeroupper`. To reiterate, this instruction should be included (before any `ret` instructions) whenever a function employs YMM register operands in order to avoid processor state transition delays. Chapter 12 contains more information about the proper use of the `vzeroupper` instruction. Output 14-1 shows the results of the sample program `AvxPackedFloatingPointArithmetic`.

Output 14-1. Sample Program `AvxPackedFloatingPointArithmetic`

Results for `AvxPfpArithmeticFloat()`

i	a	b	Add	Sub	Mul	Div	Abs	Neg
0	2.000	12.500	14.500	-10.500	25.000	0.160	2.000	-2.000
1	3.500	52.125	55.625	-48.625	182.438	0.067	3.500	-3.500
2	-10.750	17.500	6.750	-28.250	-188.125	-0.614	10.750	10.750
3	15.000	13.982	28.982	1.018	209.730	1.073	15.000	-15.000
4	-12.125	-4.750	-16.875	-7.375	57.594	2.553	12.125	12.125
5	3.875	3.063	6.938	0.813	11.867	1.265	3.875	-3.875
6	2.000	7.875	9.875	-5.875	15.750	0.254	2.000	-2.000
7	-6.350	-48.188	-54.537	41.838	305.991	0.132	6.350	6.350

Results for AvxPfpArithmeticDouble()

i	a	b	Min	Max	Sqrt a	HorAdd	HorSub
0	12.000	0.875	0.875	12.000	3.464	25.500	-1.500
1	13.500	-125.250	-125.250	13.500	3.674	-124.375	126.125
2	18.750	72.500	18.750	72.500	4.330	23.750	13.750
3	5.000	-98.375	-98.375	5.000	2.236	-25.875	170.875

Packed Floating-Point Compares

In Chapter 13, you learned how to use the `vcmps` instruction to compare two scalar double-precision floating-point numbers. In this section, you learn how to use the `vcmp` instruction to compare two packed double-precision floating-point values. This instruction performs pairwise compares of the elements in two source operands; it then sets the corresponding destination operand elements to indicate the results (all 1s for true or all 0s for false). The C++ and assembly language source code listings for sample program `AvxPackedFloatingPointCompare` are shown in Listings 14-4 and 14-5, respectively.

Listing 14-4. `AvxPackedFloatingPointCompare.cpp`

```
#include "stdafx.h"
#include "YmmVal.h"
#include <limits>
using namespace std;

extern "C" void AvxPfpCompare_(const YmmVal* a, const YmmVal* b, YmmVal c[8]);

int _tmain(int argc, _TCHAR* argv[])
{
    char buff[256];
    __declspec(align(32)) YmmVal a;
    __declspec(align(32)) YmmVal b;
    __declspec(align(32)) YmmVal c[8];

    const char* instr_names[8] =
    {
        "vcmpsqpd", "vcmpsqpd", "vcmpltpd", "vcmpdepd",
        "vcmpgtpd", "vcmpgepd", "vcmpordpd", "vcmpunordpd"
    };

    a.r64[0] = 42.125;
    a.r64[1] = -36.875;
    a.r64[2] = 22.95;
    a.r64[3] = 3.75;
```

```

b.r64[0] = -0.0625;
b.r64[1] = -67.375;
b.r64[2] = 22.95;
b.r64[3] = numeric_limits<double>::quiet_NaN();

AvxPfpCompare_(&a, &b, c);

printf("Results for AvxPackedFloatingPointCompare\n");
printf("a: %s\n", a.ToString_r64(buff, sizeof(buff), false));
printf("a: %s\n", a.ToString_r64(buff, sizeof(buff), true));
printf("\n");
printf("b: %s\n", b.ToString_r64(buff, sizeof(buff), false));
printf("b: %s\n", b.ToString_r64(buff, sizeof(buff), true));

for (int i = 0; i < 8; i++)
{
    printf("\n%s results\n", instr_names[i]);
    printf("  %s\n", c[i].ToString_x64(buff, sizeof(buff), false));
    printf("  %s\n", c[i].ToString_x64(buff, sizeof(buff), true));
}

return 0;
}

```

Listing 14-5. AvxPackedFloatingPointCompare.asm

```

.model flat,c
.code

; extern "C" void AvxPfpCompare_(const YmmVal* a, const YmmVal* b, YmmVal c[8]);
;
; Description: The following function demonstrates use of the
;             x86-AVX compare instruction vcmppd.
;
; Requires:   AVX

AvxPfpCompare_ proc
    push ebp
    mov ebp,esp

; Load argument values
    mov eax,[ebp+8]           ;eax = ptr to a
    mov ecx,[ebp+12]         ;ecx = ptr to b
    mov edx,[ebp+16]         ;edx = ptr to c
    vmovapd ymm0,ymmword ptr [eax] ;ymm0 = a
    vmovapd ymm1,ymmword ptr [ecx] ;ymm1 = b

```

```

; Compare for equality
    vcmpeqpd ymm2,ymm0,ymm1
    vmovapd ymmword ptr [edx],ymm2

; Compare for inequality
    vcmpneqpd ymm2,ymm0,ymm1
    vmovapd ymmword ptr [edx+32],ymm2

; Compare for less than
    vcmpltpd ymm2,ymm0,ymm1
    vmovapd ymmword ptr [edx+64],ymm2

; Compare for less than or equal
    vcmplepd ymm2,ymm0,ymm1
    vmovapd ymmword ptr [edx+96],ymm2

; Compare for greater than
    vcmpgtpd ymm2,ymm0,ymm1
    vmovapd ymmword ptr [edx+128],ymm2

; Compare for greater than or equal
    vcmpgepd ymm2,ymm0,ymm1
    vmovapd ymmword ptr [edx+160],ymm2

; Compare for ordered
    vcmpordpd ymm2,ymm0,ymm1
    vmovapd ymmword ptr [edx+192],ymm2

; Compare for unordered
    vcmpunordpd ymm2,ymm0,ymm1
    vmovapd ymmword ptr [edx+224],ymm2

; Zero upper 128-bit of all YMM registers to avoid potential x86-AVX
; to x86-SSE transition penalties.
    vzeroupper
    pop ebp
    ret
AvxPfpCompare_ endp
end

```

The `_tmain` function in `AvxPackedFloatingPointCompare.cpp` (see Listing 14-4) uses the C++ union `YmmVal` to initialize two packed double-precision floating-point values for test purposes. Note that the last element of `b` is assigned a value of `QNaN` in order to highlight an unordered floating-point compare. The remaining lines of `_tmain` invoke the assembly language function `_AvxPfpCompare` and print the results. The `printf` statements display the unaltered mask result of each packed double-precision floating-point compare operation.

Listing 14-5 contains the assembly language function `AvxPfpCompare_`. This function uses the `vmovapd` instruction to load the packed double-precision floating-point argument values `a` and `b` into registers `YMM0` and `YMM1`, respectively. The function then exercises the most commonly-used forms of the `vcmpdpd` instruction and saves each packed mask result to the specified array. Note that just before the function epilog, a `vzeroupper` instruction is used to avert the aforementioned x86-AVX to x86-SSE state transition performance penalties.

Like its scalar counterpart, the `vcmpdpd` instruction supports two formats: a four-operand format that uses an immediate value to specify the compare predicate and a three-operand variant that encompasses the compare predicate string within the instruction mnemonic. The `vcmpdpd` instruction also supports the same 32 compare predicates as the `vcmpsdpd` instruction. In functions that manipulate packed single-precision floating-point quantities, the `vcmpss` instruction can be used to perform compare operations. Output 14-2 shows the results of the sample program `AvxPackedFloatingPointCompare`.

Output 14-2. Sample Program `AvxPackedFloatingPointCompare`

Results for `AvxPackedFloatingPointCompare`

```
a:          42.125000000000 |          -36.875000000000
a:          22.950000000000 |           3.750000000000

b:          -0.062500000000 |          -67.375000000000
b:          22.950000000000 |           1.#QNAN00000000
```

`vcmpdpd` results

```
0000000000000000 | 0000000000000000
FFFFFFFFFFFFFFFF | 0000000000000000
```

`vcmpnqpd` results

```
FFFFFFFFFFFFFFFF | FFFFFFFFFFFFFFFF
0000000000000000 | FFFFFFFFFFFFFFFF
```

`vcmpltpd` results

```
0000000000000000 | 0000000000000000
0000000000000000 | 0000000000000000
```

`vcmplepd` results

```
0000000000000000 | 0000000000000000
FFFFFFFFFFFFFFFF | 0000000000000000
```

`vcmpgtpd` results

```
FFFFFFFFFFFFFFFF | FFFFFFFFFFFFFFFF
0000000000000000 | 0000000000000000
```

`vcmpgepd` results

```
FFFFFFFFFFFFFFFF | FFFFFFFFFFFFFFFF
FFFFFFFFFFFFFFFF | 0000000000000000
```

```

vcmpordpd results
FFFFFFFFFFFFFFFF | FFFFFFFFFFFFFFFFFF
FFFFFFFFFFFFFFFF | 0000000000000000

vcmpunordpd results
0000000000000000 | 0000000000000000
0000000000000000 | FFFFFFFFFFFFFFFFFF

```

Advanced Programming

In this section, you examine a couple of sample programs that illustrate advanced x86-AVX programming techniques using packed double-precision floating-point operands. The first sample program shows how to calculate a correlation coefficient using the x86-AVX instruction set. The second sample program computes the column means of a matrix containing double-precision floating-point values. The techniques that these programs use can also be applied to similar programs that process single-precision or double-precision floating-point arrays and matrices.

Correlation Coefficient

The next sample program is called `AvxPackedFloatingPointCorrCoef`, which explains how to use the packed floating-point capabilities of x86-AVX to calculate a statistical correlation coefficient. This program also demonstrates how to perform several common operations using packed floating-point data types, including extractions and packed horizontal additions. Listings 14-6 and 14-7 contain the C++ and assembly language source code for `AvxPackedFloatingPointCorrCoef`.

Listing 14-6. `AvxPackedFloatingPointCorrCoef.cpp`

```

#include "stdafx.h"
#include <math.h>
#include <stdlib.h>

extern "C" __declspec(align(32)) double CcEpsilon = 1.0e-12;
extern "C" bool AvxPfpCorrCoef_(const double* x, const double* y, int n,
double sums[5], double* rho);

bool AvxPfpCorrCoefCpp(const double* x, const double* y, int n, double
sums[5], double* rho)
{
    double sum_x = 0, sum_y = 0;
    double sum_xx = 0, sum_yy = 0, sum_xy = 0;

```

```

// Make sure x and y are properly aligned to a 32-byte boundary
if (((uintptr_t)x & 0x1f) != 0)
    return false;
if (((uintptr_t)y & 0x1f) != 0)
    return false;

// Make sure n is valid
if ((n < 4) || ((n & 3) != 0))
    return false;

// Calculate and save sum variables
for (int i = 0; i < n; i++)
{
    sum_x += x[i];
    sum_y += y[i];
    sum_xx += x[i] * x[i];
    sum_yy += y[i] * y[i];
    sum_xy += x[i] * y[i];
}

sums[0] = sum_x;
sums[1] = sum_y;
sums[2] = sum_xx;
sums[3] = sum_yy;
sums[4] = sum_xy;

// Calculate rho
double rho_num = n * sum_xy - sum_x * sum_y;
double rho_den = sqrt(n * sum_xx - sum_x * sum_x) * sqrt(n * sum_yy -
sum_y * sum_y);

if (rho_den >= CcEpsilon)
{
    *rho = rho_num / rho_den;
    return true;
}
else
{
    *rho = 0;
    return false;
}
}

int _tmain(int argc, _TCHAR* argv[])
{
    const int n = 100;
    __declspec(align(32)) double x[n];
    __declspec(align(32)) double y[n];

```

```

double sums1[5], sums2[5];
double rho1, rho2;

srand(17);
for (int i = 0; i < n; i++)
{
    x[i] = rand();
    y[i] = x[i] + ((rand() % 6000) - 3000);
}

bool rc1 = AvxPfpCorrCoefCpp(x, y, n, sums1, &rho1);
bool rc2 = AvxPfpCorrCoef_(x, y, n, sums2, &rho2);

printf("Results for AvxPackedFloatingPointCorrCoef\n\n");

if (!rc1 || !rc2)
{
    printf("Invalid return code (rc1: %d, rc2: %d)\n", rc1, rc2);
    return 1;
}

printf("rho1: %.8lf rho2: %.8lf\n", rho1, rho2);
printf("\n");
printf("sum_x: %12.0lf %12.0lf\n", sums1[0], sums2[0]);
printf("sum_y: %12.0lf %12.0lf\n", sums1[1], sums2[1]);
printf("sum_xx: %12.0lf %12.0lf\n", sums1[2], sums2[2]);
printf("sum_yy: %12.0lf %12.0lf\n", sums1[3], sums2[3]);
printf("sum_xy: %12.0lf %12.0lf\n", sums1[4], sums2[4]);
return 0;
}

```

Listing 14-7. AvxPackedFloatingPointCorrCoef_.asm

```

.model flat,c
.code
extern CcEpsilon:real8

; extern "C" bool AvxPfpCorrCoef_(const double* x, const double* y, int n,
double sums[5], double* rho);
;
; Description: The following function computes the correlation
; coefficient for the specified x and y arrays.
;
; Requires: AVX

AvxPfpCorrCoef_ proc
    push ebp
    mov ebp,esp

```

```

; Load and validate argument values
    mov eax,[ebp+8]           ;eax = ptr to x
    test eax,1fh
    jnz BadArg               ;jump if x is not aligned
    mov edx,[ebp+12]        ;edx = ptr to y
    test edx,1fh
    jnz BadArg               ;jump if y is not aligned

    mov ecx,[ebp+16]        ;ecx = n
    cmp ecx,4
    jl BadArg                ;jump if n < 4
    test ecx,3
    jnz BadArg               ;is n evenly divisible by 4?
    shr ecx,2                ;jump if no
                                ;ecx = num iterations

; Initialize sum variables to zero
    vxorpd ymm3,ymm3,ymm3   ;ymm3 = packed sum_x
    vmovapd ymm4,ymm3       ;ymm4 = packed sum_y
    vmovapd ymm5,ymm3       ;ymm5 = packed sum_xx
    vmovapd ymm6,ymm3       ;ymm6 = packed sum_yy
    vmovapd ymm7,ymm3       ;ymm7 = packed sum_xy

; Calculate intermediate packed sum variables
@@:   vmovapd ymm0,ymmword ptr [eax] ;ymm0 = packed x values
      vmovapd ymm1,ymmword ptr [edx] ;ymm1 = packed y values

      vaddpd ymm3,ymm3,ymm0         ;update packed sum_x
      vaddpd ymm4,ymm4,ymm1         ;update packed sum_y

      vmulpd ymm2,ymm0,ymm1         ;ymm2 = packed xy values
      vaddpd ymm7,ymm7,ymm2         ;update packed sum_xy

      vmulpd ymm0,ymm0,ymm0         ;ymm0 = packed xx values
      vmulpd ymm1,ymm1,ymm1         ;ymm1 = packed yy values
      vaddpd ymm5,ymm5,ymm0         ;update packed sum_xx
      vaddpd ymm6,ymm6,ymm1         ;update packed sum_yy

      add eax,32                    ;update x ptr
      add edx,32                    ;update y ptr
      dec ecx                        ;update loop counter
      jnz @B                         ;repeat if not finished

; Calculate final sum variables
    vextractf128 xmm0,ymm3,1
    vaddpd xmm1,xmm0,xmm3
    vhaddpd xmm3,xmm1,xmm1        ;xmm3[63:0] = sum_x

```



```

vextractf128 xmm0,ymm4,1
vaddpd xmm1,xmm0,xmm4
vhaddpd xmm4,xmm1,xmm1                ;xmm4[63:0] = sum_y

vextractf128 xmm0,ymm5,1
vaddpd xmm1,xmm0,xmm5
vhaddpd xmm5,xmm1,xmm1                ;xmm5[63:0] = sum_xx

vextractf128 xmm0,ymm6,1
vaddpd xmm1,xmm0,xmm6
vhaddpd xmm6,xmm1,xmm1                ;xmm6[63:0] = sum_yy

vextractf128 xmm0,ymm7,1
vaddpd xmm1,xmm0,xmm7
vhaddpd xmm7,xmm1,xmm1                ;xmm7[63:0] = sum_xy

; Save final sum variables
mov eax,[ebp+20]                       ;eax = ptr to sums array
vmovsd real8 ptr [eax],xmm3            ;save sum_x
vmovsd real8 ptr [eax+8],xmm4         ;save sum_y
vmovsd real8 ptr [eax+16],xmm5        ;save sum_xx
vmovsd real8 ptr [eax+24],xmm6        ;save sum_yy
vmovsd real8 ptr [eax+32],xmm7        ;save sum_xy

; Calculate rho numerator
; rho_num = n * sum_xy - sum_x * sum_y;
vcvttsi2sd xmm2,xmm2,dword ptr [ebp+16] ;xmm2 = n
vmulsd xmm0,xmm2,xmm7                 ;xmm0= n * sum_xy
vmulsd xmm1,xmm3,xmm4                 ;xmm1 = sum_x * sum_y
vsubsd xmm7,xmm0,xmm1                 ;xmm7 = rho_num

; Calculate rho denominator
; t1 = sqrt(n * sum_xx - sum_x * sum_x)
; t2 = sqrt(n * sum_yy - sum_y * sum_y)
; rho_den = t1 * t2
vmulsd xmm0,xmm2,xmm5                 ;xmm0 = n * sum_xx
vmulsd xmm3,xmm3,xmm3                 ;xmm3 = sum_x * sum_x
vsubsd xmm3,xmm0,xmm3                 ;xmm3 = n * sum_xx - sum_x * sum_x
vsqrtsd xmm3,xmm3,xmm3                ;xmm3 = t1

vmulsd xmm0,xmm2,xmm6                 ;xmm0 = n * sum_yy
vmulsd xmm4,xmm4,xmm4,xmm4           ;xmm4 = sum_y * sum_y
vsubsd xmm4,xmm0,xmm4                 ;xmm4 = n * sum_yy - sum_y * sum_y
vsqrtsd xmm4,xmm4,xmm4                ;xmm4 = t2

vmulsd xmm0,xmm3,xmm4                 ;xmm0 = rho_den

```

```

; Calculate final value of rho
    xor eax,eax                ;clear upper bits of eax
    vcomisd xmm0,[CcEpsilon]   ;is rho_den < CcEpsilon?
    setae al                   ;set return code
    jb BadRho                  ;jump if rho_den < CcEpsilon

    vdivsd xmm1,xmm7,xmm0      ;xmm1 = rho
SvRho: mov edx,[ebp+24]        ;eax = ptr to rho
    vmovsd real8 ptr [edx],xmm1 ;save rho

    vzeroupper

Done: pop ebp
    ret

; Error handlers
BadRho: vxorpd xmm1,xmm1,xmm1  ;rho = 0
    jmp SvRho
BadArg: xor eax,eax           ;eax = invalid arg ret code
    jmp Done

AvxPfpCorrCoef_ endp
end

```

A correlation coefficient measures the strength of a linear association between two data sets or variables. Correlation coefficients can range in value from -1 to +1, signifying either a perfect negative or perfect positive linear relationship between the variables. Real-world correlation coefficients are rarely equal to these limits. A correlation coefficient of zero indicates that the data sets are not linearly associated. The sample program `AvxPackedFloatingPointCorrCoef` uses the following formula to calculate a correlation coefficient:

$$\rho = \frac{n \sum_i x_i y_i - \sum_i x_i \sum_i y_i}{\sqrt{\left[n \sum_i x_i^2 - \left(\sum_i x_i \right)^2 \right]} \sqrt{\left[n \sum_i y_i^2 - \left(\sum_i y_i \right)^2 \right]}}$$

You can see from the correlation coefficient formula that the sample program must calculate five separate sum variables:

$$\begin{aligned} \text{sum_x} &= \sum_i x_i & \text{sum_y} &= \sum_i y_i \\ \text{sum_xx} &= \sum_i x_i^2 & \text{sum_yy} &= \sum_i y_i^2 & \text{sum_xy} &= \sum_i x_i y_i \end{aligned}$$

Listing 14-6 shows a C++ implementation of the correlation coefficient algorithm. The function `AvxPfpCorrCoefCpp` computes a correlation coefficient between the data arrays `x` and `y`. Note that both of these arrays must be aligned to a 32-byte boundary. Also note that the number of elements `n` must be evenly divisible by four. These

restrictions are enforced in order to facilitate 256-bit wide packed arithmetic operations in the corresponding x86-AVX assembly language function. The processing loop in `AvxPfpCorrCoefCxx` sweeps through the data arrays and computes the required sum variables. It then saves these values to the `sums` array and calculates the intermediate values `rho_num` and `rho_den`. Before computing the final value of `rho`, the function verifies that `rho_den` is greater than or equal to `CcEpsilon`.

Following its function prolog, the assembly language function `AvxPfpCorrCoefCxx` (see Listing 14-7) performs the requisite array alignment and size validations. It then initializes packed versions of `sum_x`, `sum_y`, `sum_xx`, `sum_yy`, and `sum_xy` to zero using registers `YMM3-YMM7`, respectively. During each iteration of the main loop, the function processes four elements from arrays `x` and `y` using packed double-precision floating-point arithmetic. This means that the loop maintains four distinct intermediate values for each of the aforementioned sum variables.

Following completion of the main loop, the function must reduce each packed sum variable to a final result. A `vextractf128` (Extract Packed Floating-Point Values) instruction copies the upper 128-bits of each 256-bit wide packed sum variable to an XMM register. The function then calculates a final result for each sum variable using the `vaddpd` and `vhaddpd` instructions. Figure 14-1 illustrates this technique for the variable `sum_x`. The final sum values are then saved to the `sums` array for comparison purposes with the C++ implementation of the algorithm.

Initial packed value of `sum_x`

1298.0	3625.0	1710.0	2030.0	ymm3
--------	--------	--------	--------	------

`vextractf128 xmm0,ymm3,1`

0.0	0.0	1298.0	3625.0	ymm0
-----	-----	--------	--------	------

`vaddpd xmm1,xmm0,xmm3`

0.0	0.0	3008.0	5655.0	ymm1
-----	-----	--------	--------	------

`vhaddpd xmm3,xmm1,xmm1`

0.0	0.0	8663.0	8663.0	ymm3
-----	-----	--------	--------	------

Figure 14-1. Calculation of final `sum_x` using `vextractf128`, `vaddpd`, and `vhaddpd`

The value of `rho` is then computed using ordinary x86-AVX scalar double-precision floating-point arithmetic. Note that the `vcvttsi2sd xmm2,xmm2,dword ptr [ebp+16]` instruction requires two source operands. The second source operand specifies the signed doubleword integer that is converted to a double-precision floating-point value. This instruction also sets `des[127:64] = src1[127:64]`. Also note that before computing the final value of `rho`, the function `AvxPfpCorrCoefCxx` employs a `vcmisd` instruction to confirm that `rho_den` is greater than or equal to `CcEpsilon`. A `vzeroupper` instruction is included just before the function epilog. The results of sample program `AvxPackedFloatingPointCorrCoef` are shown in Output 14-3.

Output 14-3. Sample Program AvxPackedFloatingPointCorrCoef

Results for AvxPackedFloatingPointCorrCoef

rho1: 0.98083554 rho2: 0.98083554

```

sum_x:      1549166      1549166
sum_y:      1537789      1537789
sum_xx:    32934744842  32934744842
sum_yy:    32471286601  32471286601
sum_xy:    32532024390  32532024390

```

Matrix Column Means

The final sample program of this chapter, AvxPackedFloatingPointColMeans, uses the x86-AVX instruction set to calculate the arithmetic mean of each column in a matrix of double-precision floating-point values. The C++ and assembly language source code are shown in Listings 14-8 and 14-9, respectively.

Listing 14-8. AvxPackedFloatingPointColMeans.cpp

```

#include "stdafx.h"
#include <memory.h>
#include <stdlib.h>

extern "C" bool AvxPfpColMeans_(const double* x, int nrows, int ncols,
double* col_means);

bool AvxPfpColMeansCpp(const double* x, int nrows, int ncols, double*
col_means)
{
    // Make sure nrows and ncols are valid
    if ((nrows <= 0) || (ncols <= 0))
        return false;

    // Make sure col_means is properly aligned
    if (((uintptr_t)col_means & 0x1f) != 0)
        return false;

    // Calculate column means
    memset(col_means, 0, ncols * sizeof(double));

    for (int i = 0; i < nrows; i++)
    {
        for (int j = 0; j < ncols; j++)
            col_means[j] += x[i * ncols + j];
    }
}

```

```

    for (int j = 0; j < ncols; j++)
        col_means[j] /= nrows;

    return true;
}

int _tmain(int argc, _TCHAR* argv[])
{
    const int nrows = 13;
    const int ncols = 11;
    double* x = (double*)malloc(nrows * ncols * sizeof(double));
    double* col_means1 = (double*)_aligned_malloc(ncols * sizeof(double), 32);
    double* col_means2 = (double*)_aligned_malloc(ncols * sizeof(double), 32);

    srand(47);
    rand();

    for (int i = 0; i < nrows; i++)
    {
        for (int j = 0; j < ncols; j++)
            x[i * ncols + j] = rand() % 511;
    }

    bool rc1 = AvxPfpColMeansCpp(x, nrows, ncols, col_means1);
    bool rc2 = AvxPfpColMeans_(x, nrows, ncols, col_means2);

    printf("Results for sample program AvxPackedFloatingPointColMeans\n");

    if (rc1 != rc2)
    {
        printf("Bad return code (rc1 = %d, rc2 = %d)\n", rc1, rc2);
        return 1;
    }

    printf("\nTest Matrix\n");
    for (int i = 0; i < nrows; i++)
    {
        printf("row %2d: ", i);
        for (int j = 0; j < ncols; j++)
            printf("%5.0lf ", x[i * ncols + j]);
        printf("\n");
    }
    printf("\n");
}

```

```

    for (int j = 0; j < ncols; j++)
    {
        printf("col_means1[%2d]: %12.4lf  ", j, col_means1[j]);
        printf("col_means2[%2d]: %12.4lf  ", j, col_means2[j]);
        printf("\n");
    }

    free(x);
    _aligned_free(col_means1);
    _aligned_free(col_means2);
    return 0;
}

```

Listing 14-9. AvxPackedFloatingPointColMeans_.asm

```

        .model flat,c
        .code

; extern "C" bool AvxPfpColMeans_(const double* x, int nrows, int ncols,
double* col_means)
;
; Description: The following function computes the mean value of each
;               column in a matrix of DFP values.
;
; Requires:     AVX

AvxPfpColMeans_ proc
    push ebp
    mov  ebp,esp
    push ebx
    push esi
    push edi

; Load and validate arguments
    mov  esi,[ebp+8]                ;esi = ptr to x

    xor  eax,eax
    mov  edx,[ebp+12]              ;edx = nrows
    test edx,edx
    jle  BadArg                    ;jump if nrows <= 0

    mov  ecx,[ebp+16]              ;ecx = ncols
    test ecx,ecx
    jle  BadArg                    ;jump if ncols <= 0

    mov  edi,[ebp+20]              ;edi = ptr to col_means
    test edi,1fh
    jnz  BadArg                    ;jump if col_means not aligned

```

```

; Set col_means to zero
    mov ebx,ecx                ;ebx = ncols
    shl ecx,1                 ;ecx = num dowrds in col_means
    rep stosd                  ;set col_means to zero

; Compute the sum of each column in x
LP1:  mov edi,[ebp+20]         ;edi = ptr to col_means
      xor ecx,ecx             ;ecx = col_index

LP2:  mov eax,ecx              ;eax = col_index
      add eax,4
      cmp eax,ebx             ;4 or more columns remaining?
      jg @F                    ;jump if col_index + 4 > ncols

; Update col_means using next four columns
      vmovupd ymm0,ymmword ptr [esi] ;load next 4 cols of cur row
      vaddpd ymm1,ymm0,ymmword ptr [edi] ;add to col_means
      vmovapd ymmword ptr [edi],ymm1 ;save updated col_means
      add ecx,4                ;col_index += 4
      add esi,32                ;update x ptr
      add edi,32                ;update col_means ptr
      jmp NextColSet

@@:   sub eax,2
      cmp eax,ebx             ;2 or more columns remaining?
      jg @F                    ;jump if col_index + 2 > ncols

; Update col_means using next two columns
      vmovupd xmm0,xmmword ptr [esi] ;load next 2 cols of cur row
      vaddpd xmm1,xmm0,xmmword ptr [edi] ;add to col_means
      vmovapd xmmword ptr [edi],xmm1 ;save updated col_means
      add ecx,2                ;col_index += 2
      add esi,16                ;update x ptr
      add edi,16                ;update col_means ptr
      jmp NextColSet

; Update col_means using next column (or last column in the current row)
@@:   vmovsd xmm0,real8 ptr [esi] ;load x from last column
      vaddsd xmm1,xmm0,real8 ptr [edi] ;add to col_means
      vmovsd real8 ptr [edi],xmm1 ;save updated col_means
      add ecx,1                 ;col_index += 1
      add esi,8                 ;update x ptr

NextColSet:
      cmp ecx,ebx             ;more columns in current row?
      jl LP2                    ;jump if yes
      dec edx                  ;nrows -= 1
      jnz LP1                  ;jump if more rows

```

```

; Compute the final col_means
    mov eax,[ebp+12]                ;eax = nrows
    vcvtsi2sd xmm2,xmm2,eax        ;xmm2 = DFPF n rows
    mov edx,[ebp+16]              ;edx = ncols
    mov edi,[ebp+20]              ;edi = ptr to col_means

@@:    vmovsd xmm0,real8 ptr [edi]   ;xmm0 = col_means[i]
        vdivsd xmm1,xmm0,xmm2       ;compute final mean
        vmovsd real8 ptr [edi],xmm1 ;save col_mean[i]
        add edi,8                   ;update col_means ptr
        dec edx                     ;ncols -= 1
        jnz @B                      ;repeat until done
        mov eax,1                   ;set success return code
        vzeroupper

BadArg: pop edi
        pop esi
        pop ebx
        pop ebp
        ret

AvxPfpColMeans_ endp
        end

```

Toward the top of the `AvxPackedFloatingPointColMeans.cpp` file (see Listing 14-8) is a function named `AvxPfpColMeans`, which computes the column means of a matrix using a simple algorithm written in C++. Note that the function does not check the input array `x` for proper alignment. The reason for this is that the algorithm must be able to process a standard C++ matrix of double-precision floating-point values without any constraints on the number of rows or columns. Recall that the elements of a C++ matrix are stored in a contiguous block of memory using row-major ordering (see Chapter 2), which means that it's impossible to specify the alignment of a specific row, column, or element. The `col_means` array is tested for proper alignment since an x86-AVX assembly language function can use the `vmovapd` instruction to access the elements of a one-dimensional array without having to worry about multiple rows.

The function `_tmain` allocates and initializes a matrix of test values. Note that the `malloc` and `_aligned_malloc` functions are used to dynamically allocate storage space for matrix `x` and array `col_means`, respectively. The corresponding memory-free functions are also employed toward the end of `_tmain`. The remaining statements in `_tmain` invoke the C++ and assembly language column-mean calculating functions and print the results.

The x86-AVX assembly language function `AvxPfpColMeans_` (see Listing 14-9) performs the same argument validations as its C++ counterpart function. Next, the elements of the `col_means` array are initialized to zero since they're used to calculate the column sums. This action is carried out by the `rep stosd` instruction. In order to maximize throughput, the column summation loop uses different x86-AVX data move and add instructions depending on the current column index and the total number of columns in the matrix. For example, assume that the matrix `x` contains seven columns. The elements of the first four columns in `x` can be added to `col_means` using 256-bit wide

packed addition. The elements of the next two columns can be added to `col_means` using 128-wide packed addition, and the final column element must be added to `col_means` using scalar addition. Figure 14-2 illustrates this tactic in greater detail.

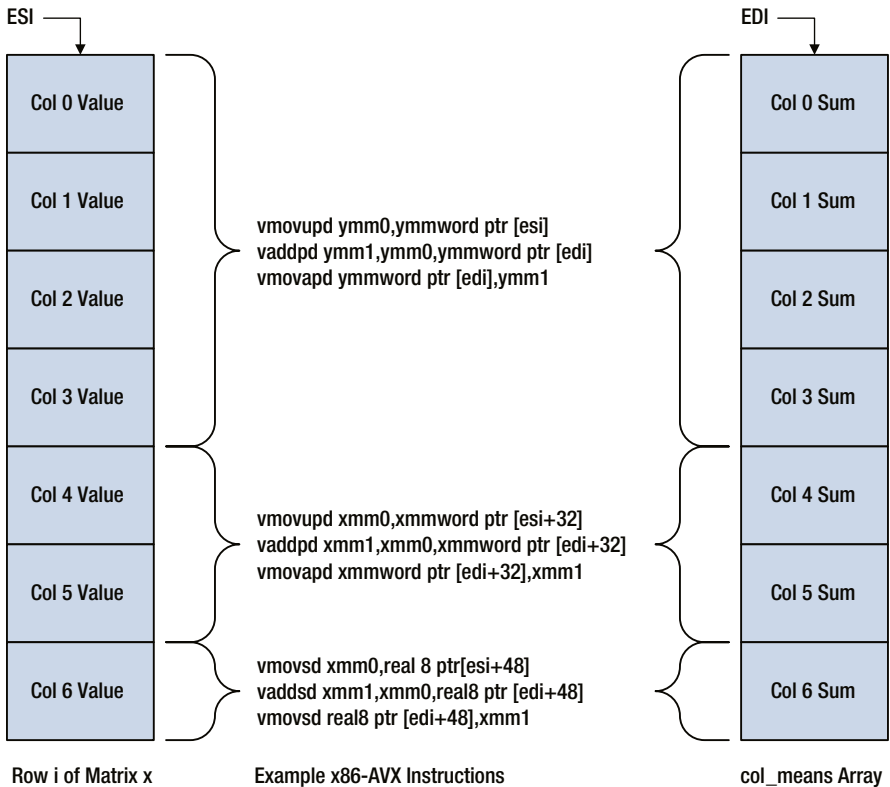

Figure 14-2. Updating the `col_means` array using different operand sizes

The top of the column summation loop, located next to label LP1, is the starting point for processing each row in matrix `x`. Prior to the first summation loop iteration, register EDX contains `nrows` and register ESI contains a pointer to `x`. Each summation loop iteration begins with a `mov edi, [ebp+20]` instruction, which loads EDI with a pointer to `col_means`. The `xor ecx, ecx` instruction initializes `col_index` to zero. Next to the label LP2, a series of instructions determines the number of columns that remain in the current row. If there are four or more columns remaining, the next four elements are added to the `col_means` array using instructions that manipulate 256-bit wide packed operands. A `vmovupd ymm0,ymmword ptr [esi]` instruction loads four elements from matrix `x` into YMM0 (recall that elements of matrix `x` are not aligned to either a 16- or 32-byte boundary). Next, a `vaddpd ymm1,ymm0,ymmword ptr [edi]` instruction sums the current matrix elements in YMM0 and the corresponding elements in `col_means`. The updated

sums are then saved to `col_means`, which is properly aligned, using a `vmovapd ymmword ptr [edi],ymm1` instruction. Registers ECX, ESI, and EDI are then updated in preparation for the next set of matrix columns.

The summation loop repeats the steps described in the previous paragraph until the number of columns remaining the current row is less than four. As soon as this condition is detected, the function knows that the elements in the remaining columns (if any) must be processed using instructions that handle 128-bit wide packed or 64-bit wide scalar operands, or both if three columns remain. This accounts for the distinct blocks of code that manage these scenarios. Following computation of the column sums, each element in `col_means` is divided by `nrows`, which yields the final column mean value. Output 14-4 shows the results for the sample program `AvxPackedFloatingPointColMeans`.

Output 14-4. Sample Program `AvxPackedFloatingPointColMeans`

Results for sample program `AvxPackedFloatingPointColMeans`

Test Matrix

row 0:	423	199	393	76	320	72	225	63	220	499	22
row 1:	311	277	174	369	189	380	509	95	449	210	324
row 2:	318	317	439	267	450	202	182	154	246	239	150
row 3:	360	508	466	274	402	240	327	442	365	291	353
row 4:	452	432	389	386	155	438	471	93	313	148	430
row 5:	76	331	341	329	388	313	336	36	75	328	224
row 6:	133	277	250	504	80	481	20	109	445	407	252
row 7:	202	131	6	338	49	41	144	428	3	240	145
row 8:	239	336	419	223	336	483	433	296	208	459	407
row 9:	198	501	208	24	475	75	30	236	461	436	36
row 10:	508	161	291	503	386	352	492	226	291	258	276
row 11:	53	499	132	339	26	346	422	159	292	411	62
row 12:	7	230	301	16	160	71	109	479	166	417	85

<code>col_means1[0]:</code>	252.3077	<code>col_means2[0]:</code>	252.3077
<code>col_means1[1]:</code>	323.0000	<code>col_means2[1]:</code>	323.0000
<code>col_means1[2]:</code>	293.0000	<code>col_means2[2]:</code>	293.0000
<code>col_means1[3]:</code>	280.6154	<code>col_means2[3]:</code>	280.6154
<code>col_means1[4]:</code>	262.7692	<code>col_means2[4]:</code>	262.7692
<code>col_means1[5]:</code>	268.7692	<code>col_means2[5]:</code>	268.7692
<code>col_means1[6]:</code>	284.6154	<code>col_means2[6]:</code>	284.6154
<code>col_means1[7]:</code>	216.6154	<code>col_means2[7]:</code>	216.6154
<code>col_means1[8]:</code>	271.8462	<code>col_means2[8]:</code>	271.8462
<code>col_means1[9]:</code>	334.0769	<code>col_means2[9]:</code>	334.0769
<code>col_means1[10]:</code>	212.7692	<code>col_means2[10]:</code>	212.7692

Summary

This chapter focused on the packed floating-point capabilities of x86-AVX. You learned how to perform basic arithmetic operations using 256-bit wide packed floating-point operands. You also examined some sample code that demonstrated useful SIMD processing techniques for floating-point arrays and matrices. The sample code reinforced what you learned about the advantages of the x86-AVX instruction set in Chapters 13 and 14: simpler assembly language coding and elimination of most register-to-register data transfer operations. You also see these same benefits in the next chapter, which explains how to create functions that exploit the packed integer resources of x86-AVX.



X86-AVX Programming - Packed Integers

This chapter illustrates how to use the x86-AVX instruction set to perform operations using 256-bit wide packed integer operands. It includes a couple of sample programs that explain how to carry out basic packed integer arithmetic and unpack operations. It also contains a few of sample programs that implement commonly-used image processing algorithms using 8-bit unsigned integers. All of the sample programs in this chapter require a processor and operating system that support AVX2.

Packed Integer Fundamentals

This section demonstrates how to perform packed integer operations using the x86-AVX instruction set. The first sample program illustrates essential packed integer arithmetic operations using 256-bit wide operands. The second sample program shows how to perform integer unpack and pack operations using the YMM registers. This program also highlights how these instructions carry out their operations using two separate 128-bit wide lanes.

Packed Integer Arithmetic

The first sample program of this section, called `AvxPackedIntegerArithmetic`, demonstrates how to perform common arithmetic operations using 256-bit wide packed integer operands. It also exemplifies some of the packed integer processing differences between x86-AVX and x86-SSE. The C++ and x86-AVX assembly language source code files for this program are shown in Listings 15-1 and 15-2, respectively.

Listing 15-1. AvxPackedIntegerArithmetic.cpp

```

#include "stdafx.h"
#include "YmmVal.h"

extern "C" void AvxPii16_(YmmVal* a, YmmVal* b, YmmVal c[6]);
extern "C" void AvxPii32_(YmmVal* a, YmmVal* b, YmmVal c[5]);

void AvxPii16(void)
{
    __declspec(align(32)) YmmVal a;
    __declspec(align(32)) YmmVal b;
    __declspec(align(32)) YmmVal c[6];

    a.i16[0] = 10;      b.i16[0] = 1000;
    a.i16[1] = 20;      b.i16[1] = 2000;
    a.i16[2] = 3000;   b.i16[2] = 30;
    a.i16[3] = 4000;   b.i16[3] = 40;

    a.i16[4] = 30000;  b.i16[4] = 3000;      // add overflow
    a.i16[5] = 6000;   b.i16[5] = 32000;     // add overflow
    a.i16[6] = 2000;   b.i16[6] = -31000;    // sub overflow
    a.i16[7] = 4000;   b.i16[7] = -30000;    // sub overflow

    a.i16[8] = 4000;   b.i16[8] = -2500;
    a.i16[9] = 3600;   b.i16[9] = -1200;
    a.i16[10] = 6000;  b.i16[10] = 9000;
    a.i16[11] = -20000; b.i16[11] = -20000;

    a.i16[12] = -25000; b.i16[12] = -27000;    // add overflow
    a.i16[13] = 8000;   b.i16[13] = 28700;    // add overflow
    a.i16[14] = 3;      b.i16[14] = -32766;    // sub overflow
    a.i16[15] = -15000; b.i16[15] = 24000;     // sub overflow

    AvxPii16_(&a, &b, c);

    printf("\nResults for AvxPii16()\n\n");
    printf("i      a      b  vpaddw vpaddsw vpsubw vpsubsw vpminsw
vpmasw\n");
    printf("-----\n");

    for (int i = 0; i < 16; i++)
    {
        const char* fs = "%7d ";

        printf("%2d ", i);
        printf(fs, a.i16[i]);
        printf(fs, b.i16[i]);
        printf(fs, c[0].i16[i]);
        printf(fs, c[1].i16[i]);
    }
}

```

```

        printf(fs, c[2].i16[i]);
        printf(fs, c[3].i16[i]);
        printf(fs, c[4].i16[i]);
        printf(fs, c[5].i16[i]);
        printf("\n");
    }
}

void AvxPiI32(void)
{
    __declspec(align(32)) YmmVal a;
    __declspec(align(32)) YmmVal b;
    __declspec(align(32)) YmmVal c[5];

    a.i32[0] = 64;      b.i32[0] = 4;
    a.i32[1] = 1024;   b.i32[1] = 5;
    a.i32[2] = -2048;  b.i32[2] = 2;
    a.i32[3] = 8192;   b.i32[3] = 5;
    a.i32[4] = -256;   b.i32[4] = 8;
    a.i32[5] = 4096;   b.i32[5] = 7;
    a.i32[6] = 16;     b.i32[6] = 3;
    a.i32[7] = 512;    b.i32[7] = 6;

    AvxPiI32_(&a, &b, c);

    printf("\nResults for AvxPiI32()\n\n");
    printf("i      a      b      vphadd vphsubd vpmulld vpsllvd←
vpsravd\n");
    printf("-----\n");

    for (int i = 0; i < 8; i++)
    {
        const char* fs = "%8d ";

        printf("%2d ", i);
        printf(fs, a.i32[i]);
        printf(fs, b.i32[i]);
        printf(fs, c[0].i32[i]);
        printf(fs, c[1].i32[i]);
        printf(fs, c[2].i32[i]);
        printf(fs, c[3].i32[i]);
        printf(fs, c[4].i32[i]);
        printf("\n");
    }
}

```

```
int _tmain(int argc, _TCHAR* argv[])
{
    AvxPiI16();
    AvxPiI32();
    return 0;
}
```

Listing 15-2. AvxPackedIntegerArithmetic_.asm

```
.model flat,c
.code

; extern "C" void AvxPiI16_(YmmVal* a, YmmVal* b, YmmVal c[6]);
;
; Description: The following function illustrates use of various
;              packed 16-bit integer arithmetic instructions
;              using 256-bit wide operands.
;
; Requires:    AVX2

AvxPiI16_ proc
    push ebp
    mov ebp,esp

; Load argument values
    mov eax,[ebp+8]           ;eax = ptr to a
    mov ecx,[ebp+12]        ;ecx = ptr to b
    mov edx,[ebp+16]        ;edx = ptr to c

; Load a and b, which must be properly aligned
    vmovdqa ymm0,ymmword ptr [eax] ;ymm0 = a
    vmovdqa ymm1,ymmword ptr [ecx] ;ymm1 = b

; Perform packed arithmetic operations
    vpaddw ymm2,ymm0,ymm1      ;add
    vpaddsw ymm3,ymm0,ymm1    ;add with signed saturation
    vpsubw ymm4,ymm0,ymm1     ;sub
    vpsubsw ymm5,ymm0,ymm1    ;sub with signed saturation
    vpminsw ymm6,ymm0,ymm1    ;signed minimums
    vpmxsw ymm7,ymm0,ymm1     ;signed maximums

; Save results
    vmovdqa ymmword ptr [edx],ymm2 ;save vpaddw result
    vmovdqa ymmword ptr [edx+32],ymm3 ;save vpaddsw result
    vmovdqa ymmword ptr [edx+64],ymm4 ;save vpsubw result
    vmovdqa ymmword ptr [edx+96],ymm5 ;save vpsubsw result
    vmovdqa ymmword ptr [edx+128],ymm6 ;save vpminsw result
    vmovdqa ymmword ptr [edx+160],ymm7 ;save vpmxsw result
```

```

        vzeroupper
        pop ebp
        ret
AvxPiI16_ endp

; extern "C" void AvxPiI32_(YmmVal* a, YmmVal* b, YmmVal c[5]);
;
; Description: The following function illustrates use of various
;             packed 32-bit integer arithmetic instructions
;             using 256-bit wide operands.
;
; Requires:   AVX2

AvxPiI32_ proc
        push ebp
        mov ebp,esp

; Load argument values
        mov eax,[ebp+8]           ;eax = ptr to a
        mov ecx,[ebp+12]        ;ecx = ptr to b
        mov edx,[ebp+16]        ;edx = ptr to c

; Load a and b, which must be properly aligned
        vmovdqa ymm0,ymmword ptr [eax]   ;ymm0 = a
        vmovdqa ymm1,ymmword ptr [ecx]   ;ymm1 = b

; Perform packed arithmetic operations
        vphaddq ymm2,ymm0,ymm1           ;horizontal add
        vphsubd ymm3,ymm0,ymm1           ;horizontal sub
        vpmulld ymm4,ymm0,ymm1           ;signed mul (low 32 bits)
        vpsllvd ymm5,ymm0,ymm1           ;shift left logical
        vpsravd ymm6,ymm0,ymm1           ;shift right arithmetic

; Save results
        vmovdqa ymmword ptr [edx],ymm2   ;save vphaddq result
        vmovdqa ymmword ptr [edx+32],ymm3 ;save vphsubd result
        vmovdqa ymmword ptr [edx+64],ymm4 ;save vpmulld result
        vmovdqa ymmword ptr [edx+96],ymm5 ;save vpsllvd result
        vmovdqa ymmword ptr [edx+128],ymm6 ;save vpsravd result

        vzeroupper
        pop ebp
        ret
AvxPiI32_ endp
end

```

The C++ file `AvxPackedIntegerArithmetic.cpp` (see Listing 15-1) includes a function named `AvxPiI16` that initializes a couple of `YmmVal` variables using 16-bit signed integers. It then calls the assembly language function `AvxPiI16_`, which carries out a number of common packed arithmetic operations, including addition, subtraction, signed minimums, and signed maximums. The results of these operations are then displayed using a series of `printf` statements. `AvxPackedIntegerArithmetic.cpp` also includes a function named `AvxPiI32` that arranges a couple of `YmmVal` instances using 32-bit signed integers. These `YmmVal` values are passed to the assembly language function named `AvxPiI32_`, which performs horizontal addition and subtraction, multiplication, and variable shift operations.

Following its function prolog, function `AvxPiI16_` loads pointer argument values `a`, `b`, and `c` into registers `EAX`, `ECX`, and `EDX`, respectively. The instruction `vmovdqa ymm0, ymmword ptr [eax]` loads the variable `a` into register `YMM0`. Note that the `vmovdqa` instruction requires any 256-bit wide memory operand that it references to be properly aligned on a 32-byte boundary (the `vmovdqu` instruction can be used for unaligned operands). Another `vmovdqa` instruction loads `b` into `YMM1`. A series of arithmetic instructions follows next, including packed signed integer addition (`vpaddw` and `vpaddsw`), subtraction (`vpsubw` and `vpsubsw`), signed minimums (`vpminsw`), and signed maximums (`vpmaxsw`). The results are then saved to the array `c`, which also must be properly aligned.

The function `AvxPiI32_` uses the same sequence of instructions as `AvxPiI16_` to load `a` and `b` into registers `YMM0` and `YMM1`. It then performs some common arithmetic operations, including horizontal addition (`vphadd`), horizontal subtraction (`vphsubd`), and signed 32-bit multiplication (`vpmulld`). The `AvxPiI32_` function also exercises the variable bits shift instructions `vpsllvd` (Variable Bit Shift Left Logical) and `vpsravd` (Variable Bit Shift Right Arithmetic). These instructions, first included with AVX2, shift the doubleword elements of the first source operand using bit counts that are specified by the corresponding doubleword elements of the second source operand, as illustrated in Figure 15-1. Note that both `AvxPiI16_` and `AvxPiI32_` include a `vzeroupper` instruction prior to their respective epilogs. Output 15-1 shows the results of the sample program `AvxPackedIntegerArithmetic`.

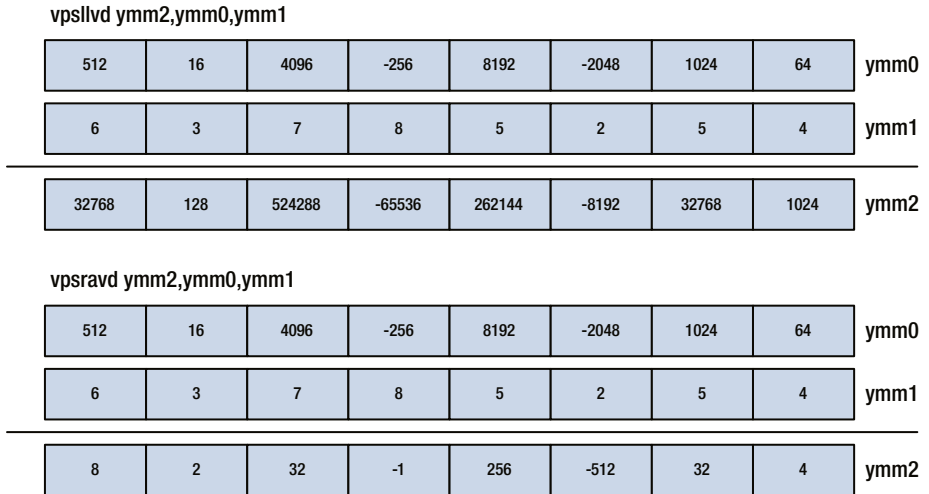

Figure 15-1. Execution of the `vpsllvd` and `vpsravd` instructions

Output 15-1. Sample Program `AvxPackedIntegerArithmetic`

Results for `AvxPiI16()`

i	a	b	vpaddw	vpaddsw	vpsubw	vpsubsw	vpminsw	vpmaxsw
0	10	1000	1010	1010	-990	-990	10	1000
1	20	2000	2020	2020	-1980	-1980	20	2000
2	3000	30	3030	3030	2970	2970	30	3000
3	4000	40	4040	4040	3960	3960	40	4000
4	30000	3000	-32536	32767	27000	27000	3000	30000
5	6000	32000	-27536	32767	-26000	-26000	6000	32000
6	2000	-31000	-29000	-29000	-32536	32767	-31000	2000
7	4000	-30000	-26000	-26000	-31536	32767	-30000	4000
8	4000	-2500	1500	1500	6500	6500	-2500	4000
9	3600	-1200	2400	2400	4800	4800	-1200	3600
10	6000	9000	15000	15000	-3000	-3000	6000	9000
11	-20000	-20000	25536	-32768	0	0	-20000	-20000
12	-25000	-27000	13536	-32768	2000	2000	-27000	-25000
13	8000	28700	-28836	32767	-20700	-20700	8000	28700
14	3	-32766	-32763	-32763	-32767	32767	-32766	3
15	-15000	24000	9000	9000	26536	-32768	-15000	24000

Results for AvxPiI32()

i	a	b	vphadd	vphsubd	vpmulld	vpsllvd	vpsravd
0	64	4	1088	-960	256	1024	4
1	1024	5	6144	-10240	5120	32768	32
2	-2048	2	9	-1	-4096	-8192	-512
3	8192	5	7	-3	40960	262144	256
4	-256	8	3840	-4352	-2048	-65536	-1
5	4096	7	528	-496	28672	524288	32
6	16	3	15	1	48	128	2
7	512	6	9	-3	3072	32768	8

Packed Integer Unpack Operations

Like MMX and x86-SSE, the x86-AVX instruction set supports data unpack operations using various element sizes. In the next sample program, which is called `AvxPackedIntegerUnpack`, you learn about the instructions that unpack doublewords to quadwords using 256-bit wide operands. You also learn how to pack a 256-bit wide operand of doublewords to words using signed saturation. Listings 15-3 and 15-4 show the C++ and assembly language source code for the sample program `AvxPackedIntegerUnpack`.

Listing 15-3. `AvxPackedIntegerUnpack.cpp`

```
#include "stdafx.h"
#include "YmmVal.h"

extern "C" void AvxPiUnpackDQ_(YmmVal* a, YmmVal* b, YmmVal c[2]);
extern "C" void AvxPiPackDW_(YmmVal* a, YmmVal* b, YmmVal* c);

void AvxPiUnpackDQ(void)
{
    __declspec(align(32)) YmmVal a;
    __declspec(align(32)) YmmVal b;
    __declspec(align(32)) YmmVal c[2];

    a.i32[0] = 0x00000000; b.i32[0] = 0x88888888;
    a.i32[1] = 0x11111111; b.i32[1] = 0x99999999;
    a.i32[2] = 0x22222222; b.i32[2] = 0xaaaaaaaa;
    a.i32[3] = 0x33333333; b.i32[3] = 0xbbbbbbbb;

    a.i32[4] = 0x44444444; b.i32[4] = 0xcccccccc;
    a.i32[5] = 0x55555555; b.i32[5] = 0xdddddddd;
    a.i32[6] = 0x66666666; b.i32[6] = 0xeeeeeeee;
    a.i32[7] = 0x77777777; b.i32[7] = 0xffffffff;

    AvxPiUnpackDQ_(&a, &b, c);
}
```

```

printf("\nResults for AvxPiUnpackDQ()\n\n");
printf("i   a           b           vpunpckldq  vpunpckhdq\n");
printf("-----\n");

for (int i = 0; i < 8; i++)
{
    const char* fs = "0x%08X ";

    printf("%-2d ", i);
    printf(fs, a.u32[i]);
    printf(fs, b.u32[i]);
    printf(fs, c[0].u32[i]);
    printf(fs, c[1].u32[i]);
    printf("\n");
}
}

void AvxPiPackDW(void)
{
    char buff[256];
    __declspec(align(32)) YmmVal a;
    __declspec(align(32)) YmmVal b;
    __declspec(align(32)) YmmVal c;

    a.i32[0] = 10;           b.i32[0] = 32768;
    a.i32[1] = -200000;     b.i32[1] = 6500;
    a.i32[2] = 300000;     b.i32[2] = 42000;
    a.i32[3] = -4000;      b.i32[3] = -68000;

    a.i32[4] = 9000;       b.i32[4] = 25000;
    a.i32[5] = 80000;      b.i32[5] = 500000;
    a.i32[6] = 200;        b.i32[6] = -7000;
    a.i32[7] = -32769;     b.i32[7] = 12500;

    AvxPiPackDW_(&a, &b, &c);
    printf("\nResults for AvxPiPackDW()\n\n");

    printf("a lo %s\n", a.ToString_i32(buff, sizeof(buff), false));
    printf("a hi %s\n", a.ToString_i32(buff, sizeof(buff), true));
    printf("\n");

    printf("b lo %s\n", b.ToString_i32(buff, sizeof(buff), false));
    printf("b hi %s\n", b.ToString_i32(buff, sizeof(buff), true));
    printf("\n");

    printf("c lo %s\n", c.ToString_i16(buff, sizeof(buff), false));
    printf("c hi %s\n", c.ToString_i16(buff, sizeof(buff), true));
}

```

```
int _tmain(int argc, _TCHAR* argv[])
{
    AvxPiUnpackDQ();
    AvxPiPackDW();
    return 0;
}
```

Listing 15-4. AvxPackedIntegerUnpack_.asm

```
.model flat,c
.code

; extern "C" void AvxPiUnpackDQ_(YmmVal* a, YmmVal* b, YmmVal c[2]);
;
; Description: The following function demonstrates use of the
;             vpunpckldq and vpunpckhdq instructions using
;             256-bit wide operands.
;
; Requires:   AVX2

AvxPiUnpackDQ_ proc
    push ebp
    mov ebp,esp

; Load argument values
    mov eax,[ebp+8]           ;eax = ptr to a
    mov ecx,[ebp+12]        ;ecx = ptr to b
    mov edx,[ebp+16]        ;edx = ptr to c
    vmovdqa ymm0,ymmword ptr [eax] ;ymm0 = a
    vmovdqa ymm1,ymmword ptr [ecx] ;ymm1 = b

; Perform dword to qword unpacks
    vpunpckldq ymm2,ymm0,ymm1 ;unpack low doublewords
    vpunpckhdq ymm3,ymm0,ymm1 ;unpack high doublewords
    vmovdqa ymmword ptr [edx],ymm2 ;save low result
    vmovdqa ymmword ptr [edx+32],ymm3 ;save high result

    vzeroupper
    pop ebp
    ret
AvxPiUnpackDQ_ endp

; extern "C" void AviPiPackDW_(YmmVal* a, YmmVal* b, YmmVal* c);
;
; Description: The following function demonstrates use of
;             vpackssdw using 256-bit wide operands.
;
; Requires:   AVX2
```

```

AvxPiPackDW_ proc
    push ebp
    mov ebp,esp

; Load argument values
    mov eax,[ebp+8]                ;eax = ptr to a
    mov ecx,[ebp+12]               ;ecx = ptr to b
    mov edx,[ebp+16]               ;edx = ptr to c
    vmovdq ymm0,ymmword ptr [eax] ;ymm0 = a
    vmovdq ymm1,ymmword ptr [ecx] ;ymm1 = b

; Perform pack dword to word with signed saturation
    vpackssdw ymm2,ymm0,ymm1      ;ymm2 = packed words
    vmovdq ymmword ptr [edx],ymm2 ;save result

    vzeroupper
    pop ebp
    ret
AvxPiPackDW_ endp
end

```

Near the top of Listing 15-3, the function `AvxPiUnpackDQ` initializes `YmmVal` instances `a` and `b` using doubleword test values. It then invokes the assembly language function `AvxPiUnpackDQ_`, which executes the x86-AVX unpack instructions `vpunpckldq` and `vpunpckhdq`. The results from this function are then displayed using a simple for loop and several `printf` statements. The C++ code also includes a function named `AvxPiPackDW`. This function initializes two `YmmVal` variables and calls `AvxPiPackDW_` in order to demonstrate use of the `vpackssdw` (Pack with Signed Saturation Doubleword to Word) instruction.

The assembly language file `AvxPackedIntegerUnpack_.asm` (see Listing 15-4) contains the definitions for functions `AvxPiUnpackDQ_` and `AvxPiPackDW_`. The former function begins by loading argument values `a` and `b` into registers `YMM0` and `YMM1`, respectively. It then executes the `vpunpckldq` and `vpunpckhdq` instructions and saves the results to the `c` array. Recall from the discussion in Chapter 12 that many 256-bit wide x86-AVX instructions carry out their operation using two independent 128-bit wide lanes. Figure 15-2 illustrates this principle in greater detail for the instructions `vpunpckldq` and `vpunpckhdq`. This figure shows that both of these instructions perform two discrete unpack operations: one that uses register bits 255:128 (upper lane) and another that employs register bits 127:0 (lower lane). Exploitation of the YMM registers by function `AvxPiUnpackDQ_` also necessitates inclusion of a `vzeroupper` instruction prior to its epilog.

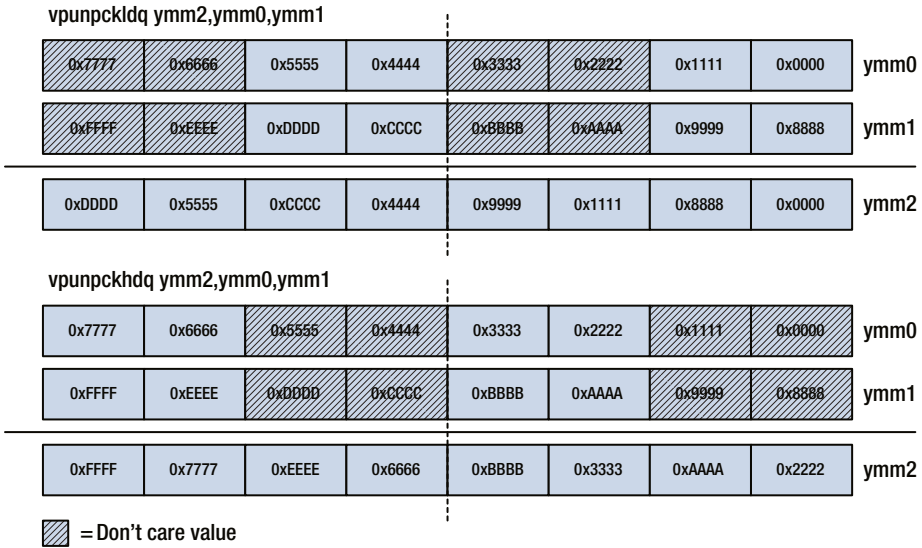

Figure 15-2. Execution of the *vpunpckldq* and *vpunpckhdq* instructions

The assembly language function `AvxPiPackDW_` also loads argument values `a` and `b` into registers `YMM0` and `YMM1`, respectively. A `vpackssdw ymm2,ymm0,ymm1` instruction converts the packed signed doubleword integers in `YMM0` and `YMM1` to packed signed word integers using signed saturation. Figure 15-3 elucidates execution of the `vpackssdw` instruction in greater detail. Output 15-2 shows the results of the sample program `AvxPackedIntegerUnpack`.

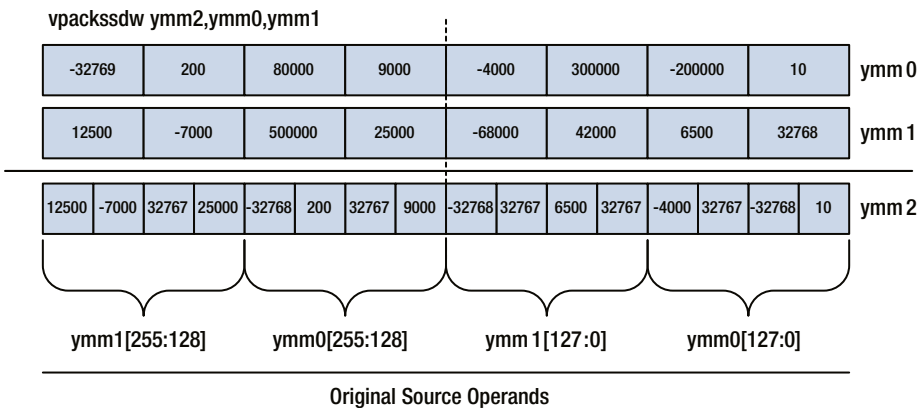

Figure 15-3. Execution of the *vpackssdw* instruction

Output 15-2. Sample Program AvxPackedIntegerUnpack

Results for AvxPiUnpackDQ()

i	a	b	vpunpckldq	vpunpckhdq
0	0x0000	0x8888	0x0000	0x2222
1	0x1111	0x9999	0x8888	0xAAAA
2	0x2222	0xAAAA	0x1111	0x3333
3	0x3333	0xBBBB	0x9999	0xBBBB
4	0x4444	0xCCCC	0x4444	0x6666
5	0x5555	0xDDDD	0xCCCC	0xEEEE
6	0x6666	0xEEEE	0x5555	0x7777
7	0x7777	0xFFFF	0xDDDD	0xFFFF

Results for AvxPiPackDW()

a lo	10	-200000		300000	-4000				
a hi	9000	80000		200	-32769				
b lo	32768	6500		42000	-68000				
b hi	25000	500000		-7000	12500				
c lo	10	-32768	32767	-4000		32767	6500	32767	-32768
c hi	9000	32767	200	-32768		25000	32767	-7000	12500

Advanced Programming

The sample programs in this section emphasize advanced programming techniques using the packed integer resources of x86-AVX. The first sample program employs the x86-AVX instruction set to implement a pixel-clipping algorithm. The second sample program is an x86-AVX implementation of the image-thresholding algorithm that you saw in Chapter 10. Besides illustrating the differences between x86-SSE and x86-AVX, both of these sample programs also demonstrate how to use some of the new packed integer instructions included with AVX2.

Image Pixel Clipping

Pixel clipping is an image-processing technique that bounds the intensity value of each pixel in an image between two threshold limits. This technique is often used to reduce the dynamic range of an image by eliminating its extremely dark and light pixels. The sample program of this section, called AvxPackedIntegerPixelClip, illustrates how to use the x86-AVX instruction set to clip the pixels of an 8-bit grayscale image. The source code files for this sample program are shown in Listings 15-5, 15-6, and 15-7.

Listing 15-5. AvxPackedIntegerPixelClip.h

```

#pragma once

#include "MiscDefs.h"

// The following structure must match the structure that's declared
// in the file AvxPackedIntegerPixelClip.asm.
typedef struct
{
    UInt8* Src;           // source buffer
    UInt8* Des;          // destination buffer
    UInt32 NumPixels;    // number of pixels
    UInt32 NumClippedPixels; // number of clipped pixels
    UInt8 ThreshLo;     // low threshold
    UInt8 ThreshHi;     // high threshold
} PcData;

// Functions defined in AvxPackedIntegerPixelClip.cpp
bool AvxPiPixelClipCpp(PcData* pc_data);

// Functions defined in AvxPackedIntegerPixelClip.asm
extern "C" bool AvxPiPixelClip_(PcData* pc_data);

// Functions defined in AvxPackedIntegerPixelClipTimed.cpp
void AvxPackedIntegerPixelClipTimed(void);

```

Listing 15-6. AvxPackedIntegerPixelClip.cpp

```

#include "stdafx.h"
#include "AvxPackedIntegerPixelClip.h"
#include <malloc.h>
#include <memory.h>
#include <stdlib.h>

bool AvxPiPixelClipCpp(PcData* pc_data)
{
    UInt32 num_pixels = pc_data->NumPixels;
    UInt8* src = pc_data->Src;
    UInt8* des = pc_data->Des;

    if ((num_pixels < 32) || ((num_pixels & 0x1f) != 0))
        return false;

    if (((uintptr_t)src & 0x1f) != 0)
        return false;
    if (((uintptr_t)des & 0x1f) != 0)
        return false;
}

```

```

    Uint8 thresh_lo = pc_data->ThreshLo;
    Uint8 thresh_hi = pc_data->ThreshHi;
    Uint32 num_clipped_pixels = 0;

    for (Uint32 i = 0; i < num_pixels; i++)
    {
        Uint8 pixel = src[i];

        if (pixel < thresh_lo)
        {
            des[i] = thresh_lo;
            num_clipped_pixels++;
        }
        else if (pixel > thresh_hi)
        {
            des[i] = thresh_hi;
            num_clipped_pixels++;
        }
        else
            des[i] = src[i];
    }

    pc_data->NumClippedPixels = num_clipped_pixels;
    return true;
}

void AvxPackedIntegerPixelClip(void)
{
    const Uint8 thresh_lo = 10;
    const Uint8 thresh_hi = 245;
    const Uint32 num_pixels = 4 * 1024 * 1024;
    Uint8* src = (Uint8*)_aligned_malloc(num_pixels, 32);
    Uint8* des1 = (Uint8*)_aligned_malloc(num_pixels, 32);
    Uint8* des2 = (Uint8*)_aligned_malloc(num_pixels, 32);

    srand(157);
    for (int i = 0; i < num_pixels; i++)
        src[i] = (Uint8)(rand() % 256);

    PcData pc_data1;
    PcData pc_data2;

    pc_data1.Src = pc_data2.Src = src;
    pc_data1.Des = des1;
    pc_data2.Des = des2;
    pc_data1.NumPixels = pc_data2.NumPixels = num_pixels;
    pc_data1.ThreshLo = pc_data2.ThreshLo = thresh_lo;
    pc_data1.ThreshHi = pc_data2.ThreshHi = thresh_hi;
}

```

```

    AvxPiPixelClipCpy(&pc_data1);
    AvxPiPixelClip_(&pc_data2);

    printf("Results for AvxPackedIntegerPixelClip\n");

    if (pc_data1.NumClippedPixels != pc_data2.NumClippedPixels)
        printf(" NumClippedPixels compare error!\n");

    printf(" NumClippedPixels1: %u\n", pc_data1.NumClippedPixels);
    printf(" NumClippedPixels2: %u\n", pc_data2.NumClippedPixels);

    if (memcmp(des1, des2, num_pixels) == 0)
        printf(" Destination buffer memory compare passed\n");
    else
        printf(" Destination buffer memory compare failed!\n");

    _aligned_free(src);
    _aligned_free(des1);
    _aligned_free(des2);
}

int _tmain(int argc, _TCHAR* argv[])
{
    AvxPackedIntegerPixelClip();
    AvxPackedIntegerPixelClipTimed();
    return 0;
}

```

Listing 15-7. AvxPackedIntegerPixelClip_.asm

```

.model flat,c

; The following structure must match the structure that's declared
; in the file AvxPackedIntegerPixelClip.h.

PcData          struct
Src              dword ?           ;source buffer
Des             dword ?           ;destination buffer
NumPixels       dword ?           ;number of pixels
NumClippedPixels dword ?         ;number of clipped pixels
ThreshLo        byte ?            ;low threshold
ThreshHi        byte ?            ;high threshold
PcData          ends

; Custom segment for constant values
PcConstVals segment readonly align(32) public

PixelScale byte 32 dup(80h)        ;Pixel Uint8 to Int8 scale value

```

```

; The following values defined are for illustrative purposes only
; Note that the align 32 directive does not work in a .const section
Test1      dword 10
Test2      qword -20
           align 32
Test3      byte 32 dup(7fh)
PcConstVals ends
           .code

; extern "C" bool AvxPiPixelClip_(PcData* pc_data);
;
; Description: The following function clips the pixels of an image
;              buffer to values between ThreshLo and ThreshHi.
;
; Requires:    AVX2, POPCNT

AvxPiPixelClip_ proc
    push ebp
    mov ebp,esp
    push ebx
    push esi
    push edi

; Load and validate arguments
    xor eax,eax
    mov ebx,[ebp+8]           ;ebx = pc_data
    mov ecx,[ebx+PcData.NumPixels] ;ecx = num_pixels
    cmp ecx,32
    jl BadArg                ;jump if num_pixels < 32
    test ecx,1fh
    jnz BadArg                ;jump if num_pixels % 32 != 0

    mov esi,[ebx+PcData.Src]   ;esi = Src
    test esi,1fh
    jnz BadArg                ;jump if Src is misaligned

    mov edi,[ebx+PcData.Des]   ;edi = Des
    test edi,1fh
    jnz BadArg                ;jump if Des is misaligned

; Create packed thresh_lo and thresh_hi data values
    vmovdqa ymm5,ymmword ptr [PixelScale]

    vpbroadcastb ymm0,[ebx+PcData.ThreshLo] ;ymm0 = thresh_lo
    vpbroadcastb ymm1,[ebx+PcData.ThreshHi] ;ymm1 = thresh_hi

    vpsubb ymm6,ymm0,ymm5      ;ymm6 = scaled thresh_lo
    vpsubb ymm7,ymm1,ymm5      ;ymm7 = scaled thresh_hi

```

```

        xor edx,edx                ;edx = num_clipped_pixels
        shr ecx,5                 ;ecx = number of 32-byte blocks

; Sweep through the image buffer and clip pixels to threshold values
@@:    vmovdqa ymm0,ymmword ptr [esi] ;ymm0 = unscaled pixels
        vpsubb ymm0,ymm0,ymm5      ;ymm0 = scaled pixels

        vpcmpgtb ymm1,ymm0,ymm7    ;mask of pixels GT thresh_hi
        vpand ymm2,ymm1,ymm7      ;new values for GT pixels

        vpcmpgtb ymm3,ymm6,ymm0    ;mask of pixels LT thresh_lo
        vpand ymm4,ymm3,ymm6      ;new values for LT pixels

        vpor ymm1,ymm1,ymm3        ;mask of all clipped pixels

        vpor ymm2,ymm2,ymm4        ;clipped pixels
        vpandn ymm3,ymm1,ymm0      ;unclipped pixels

        vpor ymm4,ymm3,ymm2        ;final scaled clipped pixels
        vpaddb ymm4,ymm4,ymm5      ;final unscaled clipped pixels

        vmovdqa ymmword ptr [edi],ymm4 ;save clipped pixels

; Update num_clipped_pixels
        vpmovmskb eax,ymm1        ;eax = clipped pixel mask
        popcnt eax,eax            ;count clipped pixels
        add edx,eax               ;update num_clipped_pixels
        add esi,32
        add edi,32
        dec ecx
        jnz @B

; Save num_clipped_pixels
        mov eax,1                 ;set success return code
        mov [ebx+PcData.NumClippedPixels],edx
        vzeroupper

BadArg: pop edi
        pop esi
        pop ebx
        pop ebp
        ret
AvxPiPixelClip_ endp
end

```

The C++ header file `AvxPackedIntegerPixelClip.h` (see Listing 15-5) declares a structure named `PcData`. This structure and its assembly language equivalent are used to maintain the pixel-clipping algorithm's data items. Toward the top of the `AvxPackedIntegerPixelClip.cpp`

file (see Listing 15-6) is a function named `AvxPiPixelClipC++`, which clips the pixels of the source image buffer using the provided threshold limits. The function starts by performing a validation check of `num_pixels` for the correct size and even divisibility by 32. Restricting the algorithm to images that contain an even multiple of 32 pixels is not as inflexible as it might appear. Most digital camera images are sized using multiples of 64 pixels due to the processing requirements of the JPEG compression technique. The image buffers `src` and `des` are then checked for proper alignment.

The algorithm used by the main processing loop is straightforward. Any pixel in the source image buffer determined to be below `thresh_lo` or above `thresh_hi` is replaced in the destination image buffer with the corresponding threshold value. Source image buffer pixels between the two threshold limits are copied to the destination buffer unaltered. The processing loop also counts the number of clipped pixels for comparison purposes with the assembly language version of the algorithm.

Listing 15-6 also includes a C++ function `AvxPackedIntegerPixelClip`, which starts its processing by dynamically allocating storage space for simulated source and destination image buffers. It then initializes each pixel in the source image buffer using a random value between 0 and 255. Following initialization of the `PcData` structure variables `pc_data1` and `pc_data2`, the function invokes the C++ and assembly language versions of the pixel-clipping algorithm. It then compares the results for any discrepancies.

Listing 15-7 shows the assembly language implementation of the pixel-clipping algorithm. It begins by declaring an assembly language version of the structure `PcData`. Next, a discrete memory segment named `PcConstVals` is defined, which contains the constant values required by the algorithm. A discrete memory segment is used here instead of a `.const` section since the latter does not allow its data items to be aligned on a 32-byte boundary. The `PcConstVals` segment `readonly align(32) public` statement defines a read-only memory segment that permits 32-byte aligned data values. Note that the first data value in this memory segment, `PixelScale`, is automatically aligned to a 32-byte boundary. Proper alignment of 256-bit wide packed values enables use of the `vmovdq` instruction. The remaining data values in `PcConstVals` are included for illustrative purposes only.

Following its prolog, the function `AvxPiPixelClip_` performs the same pixel size and buffer alignment validations as its C++ counterpart. A `vmovdq ymm5,ymmword ptr [PixelScale]` instruction loads the pixel scale value into register YMM5. This value is used to rescale image pixel values from [0, 255] to [-128, 127]. The next instruction, `vpbroadcastb ymm0, [ebx+PcData.ThreshLo]` (Broadcast Integer Data), copies the source operand byte `ThreshLo` to all 32 byte elements in YMM0. Another `vpbroadcastb` instruction performs the same operation using register YMM1 and `ThreshHi`. Both of these values are then rescaled by `PixelScale` using a `vpsubb` instruction.

Figure 15-4 highlights the sequence of instructions that carry out the pixel-clipping procedure. Each iteration of the main processing loop starts by loading a block of 32 pixels from the source image buffer into register YMM0 using a `vmovdq` instruction. The function then rescales the pixels in YMM0 using a `vpsubb ymm0,ymm0,ymm5` instruction (recall that YMM5 contains `PixelScale`). This facilitates use of the `vpcmpgtb` instruction, which computes a mask of all pixels greater than `ThreshHi`. Note that the `vpcmpgtb` instruction performs its byte compares using signed integer arithmetic, and explains the previous pixel rescaling operations. A second `vpcmpgtb` instruction calculates a mask of all pixels less than `ThreshLo`. It is important to note here that the source operands are reversed (i.e., the first operand contains the threshold values and the second operand contains the pixel values), which is required by `vpcmpgtb` in order to compute a mask of pixels less than `ThreshLo`. The function uses these threshold masks

and some packed Boolean algebra to replace all pixels above or below the threshold with the corresponding threshold limits. The updated pixel block is then saved to the destination buffer.

PixelScale									
80h	80h	80h	80h	80h	80h	80h	80h	ymm5	
Scaled ThreshLo (Unscaled = 0Ah)									
8Ah	8Ah	8Ah	8Ah	8Ah	8Ah	8Ah	8Ah	ymm6	
Scaled ThreshHi (Unscaled = F5h)									
75h	75h	75h	75h	75h	75h	75h	75h	ymm7	
vmovdqa ymm0, ymmword ptr [esi]									
21h	06h	FBh	FAh	44h	16h	08h	11h	ymm0	Unscaled Pixels
vpsubb ymm0, ymm0, ymm5									
A1h	86h	7Bh	7Ah	C4h	96h	88h	91h	ymm0	Scaled Pixels
vpcmpgtb ymm1, ymm0, ymm7									
00h	00h	FFh	FFh	00h	00h	00h	00h	ymm1	Mask of Pixels GT ThreshHi
vpand ymm2, ymm1, ymm7									
00h	00h	75h	75h	00h	00h	00h	00h	ymm2	New Values for Pixels GT ThreshHi
vpcmpgtb ymm3, ymm6, ymm0									
00h	FFh	00h	00h	00h	00h	FFh	00h	ymm3	Mask of Pixels LT ThreshLo
vpand ymm4, ymm3, ymm6									
00h	8Ah	00h	00h	00h	00h	8Ah	00h	ymm4	New Values for Pixels LT ThreshLo
vpor ymm1, ymm1, ymm3									
00h	FFh	FFh	FFh	00h	00h	FFh	00h	ymm1	Mask of All Clipped Pixels
vpor ymm2, ymm2, ymm4									
00h	8Ah	75h	75h	00h	00h	8Ah	00h	ymm2	Clipped Pixels
vpandn ymm3, ymm1, ymm0									
A1h	00h	00h	00h	C4h	96h	00h	91h	ymm3	Unclipped Pixels
vpor ymm4, ymm3, ymm2									
A1h	8Ah	75h	75h	C4h	96h	8Ah	91h	ymm4	Final Scaled Clipped Pixels
vpaddb ymm4, ymm4, ymm5									
21h	0Ah	F5h	F5h	44h	16h	0Ah	11h	ymm4	Final Unscaled Clipped Pixels

Note: The instruction sequence shown above shows only the low-order eight bytes of each YMM register.

Figure 15-4. X86-AVX instruction sequence used to perform pixel clipping

A `vpmovmskb eax,ymm1` instruction creates a mask of clipped pixels and saves this mask to register EAX (the operation performed by `vpmovmskb` corresponds to `eax[i] = ymm1[i*8+7]` for `i = 0,1,2, ... 31`). This is followed by a `popcnt eax,eax` instruction, which counts and saves the number of clipped pixels in the current pixel block to EAX. An `add edx,eax` then updates the total number of clipped pixels that's maintained in EDX. Upon completion of the main processing loop, register EDX is saved to `PcData` structure member `NumClippedPixels`.

The results of the sample program `AvxPackedIntegerPixelClip` are shown in Output 15-3. Table 15-1 presents timing measurements for the C++ and assembly language versions of the pixel-clipping algorithm using an 8MB image buffer. Unlike earlier timing measurement tables in this book, Table 15-1 does not include benchmark times for an Intel Core i3-2310M since this processor doesn't support the AVX2 instruction set.

Output 15-3. Sample Program `AvxPackedIntegerPixelClip`

Results for `AvxPackedIntegerPixelClip`

```
NumClippedPixels1: 327228
NumClippedPixels2: 327228
Destination buffer memory compare passed
```

Benchmark times saved to file `__AvxPackedIntegerPixelClipTimed.csv`

Table 15-1. Mean Execution Times (in Microseconds) for `AvxPiPixelClip` Functions

CPU	<code>AvxPiPixelClipCpp (C++)</code>	<code>AvxPiPixelClip_ (x86-AVX)</code>
Intel Core i7-4770	8866	1075
Intel Core i7-4600U	10235	1201

Image Threshold Part Deux

In Chapter 10, you examined a sample program named `SsePackedIntegerThreshold`, which used the x86-SSE instruction set to perform image thresholding of a grayscale image. It also calculated the mean intensity value of the grayscale pixels that exceeded the threshold value. In this section, an x86-AVX compatible version of the image-thresholding program is presented. The updated sample program, which is named `AvxPackedIntegerThreshold`, also substantiates the performance benefits of x86-AVX versus x86-SSE. The source code for this sample program is presented in Listings 15-8, 15-9, and 15-10.

Listing 15-8. AvxPackedIntegerThreshold.h

```

#pragma once
#include "ImageBuffer.h"

// Image threshold data structure. This structure must agree with the
// structure that's defined in AvxPackedIntegerThreshold.asm.
typedef struct
{
    UInt8* PbSrc;           // Source image pixel buffer
    UInt8* PbMask;         // Mask mask pixel buffer
    UInt32 NumPixels;      // Number of source image pixels
    UInt8 Threshold;      // Image threshold value
    UInt8 Pad[3];          // Available for future use
    UInt32 NumMaskedPixels; // Number of masked pixels
    UInt32 SumMaskedPixels; // Sum of masked pixels
    double MeanMaskedPixels; // Mean of masked pixels
} ITD;

// Functions defined in AvxPackedIntegerThreshold.cpp
extern bool AvxPiThresholdCpp(ITD* itd);
extern bool AvxPiCalcMeanCpp(ITD* itd);

// Functions defined in AvxPackedIntegerThreshold.asm
extern "C" bool AvxPiThreshold_(ITD* itd);
extern "C" bool AvxPiCalcMean_(ITD* itd);

// Functions defined in AvxPackedIntegerThresholdTimed.cpp
extern void AvxPiThresholdTimed(void);

// Miscellaneous constants
const UInt8 TEST_THRESHOLD = 96;

```

Listing 15-9. AvxPackedIntegerThreshold.cpp

```

#include "stdafx.h"
#include "AvxPackedIntegerThreshold.h"
#include <stddef.h>

extern "C" UInt32 NUM_PIXELS_MAX = 16777216;

bool AvxPiThresholdCpp(ITD* itd)
{
    UInt8* pb_src      = itd->PbSrc;
    UInt8* pb_mask     = itd->PbMask;
    UInt8 threshold    = itd->Threshold;
    UInt32 num_pixels  = itd->NumPixels;

```

```

// Make sure num_pixels is valid
if ((num_pixels == 0) || (num_pixels > NUM_PIXELS_MAX))
    return false;
if ((num_pixels & 0x1f) != 0)
    return false;

// Make sure image buffers are properly aligned
if (((uintptr_t)pb_src & 0x1f) != 0)
    return false;
if (((uintptr_t)pb_mask & 0x1f) != 0)
    return false;

// Threshold the image
for (UInt32 i = 0; i < num_pixels; i++)
    *pb_mask++ = (*pb_src++ > threshold) ? 0xff : 0x00;

return true;
}

bool AvxPiCalcMeanCpp(ITD* itd)
{
    UInt8* pb_src = itd->PbSrc;
    UInt8* pb_mask = itd->PbMask;
    UInt32 num_pixels = itd->NumPixels;

    // Make sure num_pixels is valid
    if ((num_pixels == 0) || (num_pixels > NUM_PIXELS_MAX))
        return false;
    if ((num_pixels & 0x1f) != 0)
        return false;

    // Make sure image buffers are properly aligned
    if (((uintptr_t)pb_src & 0x1f) != 0)
        return false;
    if (((uintptr_t)pb_mask & 0x1f) != 0)
        return false;

    // Calculate mean of masked pixels
    UInt32 sum_masked_pixels = 0;
    UInt32 num_masked_pixels = 0;

    for (UInt32 i = 0; i < num_pixels; i++)
    {
        UInt8 mask_val = *pb_mask++;
        num_masked_pixels += mask_val & 1;
        sum_masked_pixels += (*pb_src++ & mask_val);
    }
}

```

```

    itd->NumMaskedPixels = num_masked_pixels;
    itd->SumMaskedPixels = sum_masked_pixels;

    if (num_masked_pixels > 0)
        itd->MeanMaskedPixels = (double)sum_masked_pixels /
num_masked_pixels;
    else
        itd->MeanMaskedPixels = -1.0;

    return true;
}

void AvxPiThreshold()
{
    wchar_t* fn_src = L"..\\..\\..\\DataFiles\\TestImage2.bmp";
    wchar_t* fn_mask1 = L"__TestImage2_Mask1.bmp";
    wchar_t* fn_mask2 = L"__TestImage2_Mask2.bmp";
    ImageBuffer* im_src = new ImageBuffer(fn_src);
    ImageBuffer* im_mask1 = new ImageBuffer(*im_src, false);
    ImageBuffer* im_mask2 = new ImageBuffer(*im_src, false);
    ITD itd1, itd2;

    itd1.PbSrc = (UInt8*)im_src->GetPixelBuffer();
    itd1.PbMask = (UInt8*)im_mask1->GetPixelBuffer();
    itd1.NumPixels = im_src->GetNumPixels();
    itd1.Threshold = TEST_THRESHOLD;

    itd2.PbSrc = (UInt8*)im_src->GetPixelBuffer();
    itd2.PbMask = (UInt8*)im_mask2->GetPixelBuffer();
    itd2.NumPixels = im_src->GetNumPixels();
    itd2.Threshold = TEST_THRESHOLD;

    bool rc1 = AvxPiThresholdCpp(&itd1);
    bool rc2 = AvxPiThreshold_(&itd2);

    if (!rc1 || !rc2)
    {
        printf("Bad Threshold return code: rc1=%d, rc2=%d\n", rc1, rc2);
        return;
    }

    im_mask1->SaveToBitmapFile(fn_mask1);
    im_mask2->SaveToBitmapFile(fn_mask2);

    // Calculate mean of masked pixels
    rc1 = AvxPiCalcMeanCpp(&itd1);
    rc2 = AvxPiCalcMean_(&itd2);
}

```

```

if (!rc1 || !rc2)
{
    printf("Bad CalcMean return code: rc1=%d, rc2=%d\n", rc1, rc2);
    return;
}

printf("Results for AvxPackedIntegerThreshold\n\n");
printf("                C++                X86-AVX\n");
printf("-----\n");
printf("SumPixelsMasked: ");
printf("%12u %12u\n", itd1.SumMaskedPixels, itd2.SumMaskedPixels);
printf("NumPixelsMasked: ");
printf("%12u %12u\n", itd1.NumMaskedPixels, itd2.NumMaskedPixels);
printf("MeanPixelsMasked: ");
printf("%12.6lf %12.6lf\n", itd1.MeanMaskedPixels, ←
itd2.MeanMaskedPixels);

delete im_src;
delete im_mask1;
delete im_mask2;
}

int _tmain(int argc, _TCHAR* argv[])
{
    try
    {
        AvxPiThreshold();
        AvxPiThresholdTimed();
    }

    catch (...)
    {
        printf("Unexpected exception has occurred!\n");
        printf("File: %s (_tmain)\n", __FILE__);
    }

    return 0;
}

```

Listing 15-10. AvxPackedIntegerThreshold.asm

```

.model flat,c
extern NUM_PIXELS_MAX:dword

; Image threshold data structure (see AvxPackedIntegerThreshold.h)
ITD                struct
PbSrc              dword ?
PbMask            dword ?
NumPixels         dword ?

```

```

Threshold      byte ?
Pad            byte 3 dup(?)
NumMaskedPixels dword ?
SumMaskedPixels dword ?
MeanMaskedPixels real8 ?
ITD           ends

; Custom segment for constant values
ItConstVals segment readonly align(32) public
PixelScale     byte 32 dup(80h)           ;uint8 to int8 scale value
R8_MinusOne    real8 -1.0                 ;invalid mean value
ItConstVals    ends

                .code

; extern "C" bool AvxPiThreshold_(ITD* itd);
;
; Description: The following function performs image thresholding
;              of an 8 bits-per-pixel grayscale image.
;
; Returns:     0 = invalid size or unaligned image buffer
;              1 = success
;
; Requires:    AVX2

AvxPiThreshold_ proc
    push ebp
    mov ebp,esp
    push esi
    push edi

; Load and verify the argument values in ITD structure
    mov edx,[ebp+8]           ;edx = 'itd'
    xor eax,eax              ;set error return code
    mov ecx,[edx+ITD.NumPixels] ;ecx = NumPixels
    test ecx,ecx
    jz Done                  ;jump if num_pixels == 0
    cmp ecx,[NUM_PIXELS_MAX] ;jump if num_pixels too big
    ja Done
    test ecx,1fh
    jnz Done                 ;jump if num_pixels % 32 != 0
    shr ecx,5                ;ecx = number of packed pixels

    mov esi,[edx+ITD.PbSrc]   ;esi = PbSrc
    test esi,1fh
    jnz Done                 ;jump if misaligned
    mov edi,[edx+ITD.PbMask] ;edi = PbMask

```

```

    test edi,1fh
    jnz Done                ;jump if misaligned

; Initialize packed threshold
    vpbroadcastb ymm0,[edx+ITD.Threshold] ;ymm0 = packed threshold
    vmovdqqa ymm7,ymmword ptr [PixelScale] ;ymm7 = uint8 to int8 SF
    vpsubb ymm2,ymm0,ymm7 ;ymm1 = scaled threshold

; Create the mask image
@@:   vmovdqqa ymm0,ymmword ptr [esi] ;load next packed pixel
      vpsubb ymm1,ymm0,ymm7 ;ymm1 = scaled image pixels
      vpcmpgtb ymm3,ymm1,ymm2 ;compare against threshold
      vmovdqqa ymmword ptr [edi],ymm3 ;save packed threshold mask

      add esi,32
      add edi,32
      dec ecx
      jnz @B ;repeat until done
      mov eax,1 ;set return code

Done:  pop edi
      pop esi
      pop ebp
      ret

AvxPiThreshold_ endp

; Marco AvxPiCalcMeanUpdateSums
;
; Description: The following macro updates sum_masked_pixels in ymm4.
;              It also resets any necessary intermediate values in
;              order to prevent an overflow condition.
;
; Register contents:
;   ymm3:ymm2 = packed word sum_masked_pixels
;   ymm4 = packed dword sum_masked_pixels
;   ymm7 = packed zero
;
; Temp registers:
;   ymm0, ymm1, ymm5, ymm6

AvxPiCalcMeanUpdateSums macro

; Promote packed word sum_masked_pixels to dword
    vpunpcklwd ymm0,ymm2,ymm7
    vpunpcklwd ymm1,ymm3,ymm7
    vpunpckhwd ymm5,ymm2,ymm7
    vpunpckhwd ymm6,ymm3,ymm7

```

```

; Update packed dword sums in sum_masked_pixels
    vpaddd ymm0,ymm0,ymm1
    vpaddd ymm5,ymm5,ymm6
    vpaddd ymm4,ymm4,ymm0
    vpaddd ymm4,ymm4,ymm5

; Reset intermediate values
    xor edx,edx                ;reset update counter
    vpxor ymm2,ymm2,ymm2     ;reset sum_masked_pixels lo
    vpxor ymm3,ymm3,ymm3     ;reset sum_masked_pixels hi
    endm

; extern "C" bool AvxPiCalcMean_(ITD* itd);
;
; Description: The following function calculates the mean value of all
;             above-threshold image pixels using the mask created by
;             function AvxPiThreshold_.
;
; Returns:    0 = invalid image size or unaligned image buffer
;            1 = success
;
; Requires:   AVX2, POPCNT

AvxPiCalcMean_ proc
    push ebp
    mov ebp,esp
    push ebx
    push esi
    push edi

; Load and verify the argument values in ITD structure
    mov eax,[ebp+8]           ;eax = 'itd'
    mov ecx,[eax+ITD.NumPixels] ;ecx = NumPixels
    test ecx,ecx
    jz Error                  ;jump if num_pixels == 0
    cmp ecx,[NUM_PIXELS_MAX]
    ja Error                  ;jump if num_pixels too big
    test ecx,1fh
    jnz Error                 ;jump if num_pixels % 32 != 0
    shr ecx,5                 ;ecx = number of packed pixels

    mov edi,[eax+ITD.PbMask]  ;edi = PbMask
    test edi,1fh
    jnz Error                 ;jump if PbMask not aligned
    mov esi,[eax+ITD.PbSrc]   ;esi = PbSrc
    test esi,1fh
    jnz Error                 ;jump if PbSrc not aligned

```

```

; Initialize values for mean calculation
    xor edx,edx                ;edx = update counter
    vpxor ymm7,ymm7,ymm7      ;ymm7 = packed zero
    vmovdqa ymm2,ymm7         ;ymm2 = sum_masked_pixels (16 words)
    vmovdqa ymm3,ymm7         ;ymm3 = sum_masked_pixels (16 words)
    vmovdqa ymm4,ymm7         ;ymm4 = sum_masked_pixels (8 dwords)
    xor ebx,ebx                ;ebx = num_masked_pixels (1 dword)

; Register usage for processing loop
; esi = PbSrc, edi = PbMask, eax = scratch register
; ebx = num_pixels_masked, ecx = NumPixels / 32, edx = update counter
;
; ymm0 = packed pixel, ymm1 = packed mask
; ymm3:ymm2 = sum_masked_pixels (32 words)
; ymm4 = sum_masked_pixels (8 dwords)
; ymm5 = scratch register
; ymm6 = scratch register
; ymm7 = packed zero

@@:    vmovdqa ymm0,ymmword ptr [esi]    ;load next packed pixel
        vmovdqa ymm1,ymmword ptr [edi]    ;load next packed mask

; Update num_masked_pixels
    vpmovmskb eax,ymm1
    popcnt eax,eax
    add ebx,eax

; Update sum_masked_pixels (word values)
    vpad ymm6,ymm0,ymm1        ;set non-masked pixels to zero
    vpunpcklbw ymm0,ymm6,ymm7
    vpunpckhbw ymm1,ymm6,ymm7    ;ymm1:ymm0 = masked pixels (words)
    vpaddw ymm2,ymm2,ymm0
    vpaddw ymm3,ymm3,ymm1        ;ymm3:ymm2 = sum_masked_pixels

; Check and see if it's necessary to update the dword sum_masked_pixels
; in xmm4 and num_masked_pixels in ebx
    inc edx
    cmp edx,255
    jb NoUpdate
    AvxPiCalcMeanUpdateSums
NoUpdate:
    add esi,32
    add edi,32
    dec ecx
    jnz @B                        ;repeat loop until done

```



```

; Main processing loop is finished. If necessary, perform final update
; of sum_masked_pixels in xmm4 & num_masked_pixels in ebx.
    test edx,edx
    jz @F
    AvxPiCalcMeanUpdateSums

; Compute and save final sum_masked_pixels & num_masked_pixels
@@:    vextracti128 xmm0,ymm4,1
        vpaddd xmm1,xmm0,xmm4
        vphadd xmm2,xmm1,xmm7
        vphadd xmm3,xmm2,xmm7
        vmovd  edx,xmm3                ;edx = final sum_mask_pixels

        mov  eax,[ebp+8]                ;eax = 'itd'
        mov  [eax+ITD.SumMaskedPixels],edx ;save final sum_masked_pixels
        mov  [eax+ITD.NumMaskedPixels],ebx ;save final num_masked_pixels

; Compute mean of masked pixels
        test ebx,ebx                    ;is num_mask_pixels zero?
        jz  NoMean                       ;if yes, skip calc of mean
        vcvttsi2sd xmm0,xmm0,edx        ;xmm0 = sum_masked_pixels
        vcvttsi2sd xmm1,xmm1,ebx        ;xmm1 = num_masked_pixels
        vdivsd  xmm0,xmm0,xmm1          ;xmm0 = mean_masked_pixels
        jmp  @F

NoMean: vmovsd  xmm0,[R8_MinusOne]      ;use -1.0 for no mean
@@:    vmovsd  [eax+ITD.MeanMaskedPixels],xmm0 ;save mean
        mov  eax,1                       ;set return code
        vzeroupper

Done:   pop  edi
        pop  esi
        pop  ebx
        pop  ebp
        ret

Error:  xor  eax,eax                     ;set error return code
        jmp Done

AvxPiCalcMean_  endp
end

```

The C++ code for the sample program `AvxPackedIntegerThreshold` (see Listings 15-8 and 15-9) is nearly identical to the C++ code in `SsePackedIntegerThreshold`. The most notable change is that `num_pixels` is now tested to determine if it's an even multiple of 32 instead of 16 in functions `AvxPiThresholdCpp` and `AvxPiCalcMeanCpp`. These functions also check the source and destination image buffers for proper alignment on a 32-byte boundary.

The assembly language code in the `AvxPackedIntegerThreshold.asm` file (see Listing 15-10) contains a number of modifications that warrant discussion. The most obvious difference between the original x86-SSE implementation and the new x86-AVX version is the latter's use of the YMM registers instead of the XMM registers. This means the algorithms can process pixel blocks of 32 instead of 16. The x86-AVX version also uses instructions not supported by SSSE3, which was the level of x86-SSE used to code the original image-thresholding and mean-calculating algorithms. A custom memory segment named `ItConstVals` is also defined in order to facilitate proper alignment of the 256-bit wide constant value `PixelScale`.

The `AvxPiThreshold_` function includes some minor changes compared to its corresponding x86-SSE function. The value of structure member `NumPixels` is now tested for even divisibility by 32 instead of 16. The source and destination image buffers, `PbSrc` and `PbDes`, are also checked for 32-byte alignment. Finally, a `vpbroadcastb ymm0, [edx+ITD.Threshold]` instruction creates the packed threshold value instead of a `vpsshufb` instruction.

The original x86-SSE version included a private function named `SsePiCalcMeanUpdateSums`, which periodically updated the intermediate doubleword pixels sums and pixel counts maintained by the algorithm. The x86-AVX implementation of the algorithm implements `AvxPiCalcMeanUpdateSums` as a macro since it has fewer processing requirements. The primary reason for the reduced processing requirements is a more efficient method of counting the masked pixels.

The `AvxPiCalcMean_` function also includes the aforementioned sizes and alignment checks of `NumPixels` and the image buffers. The main processing loop now uses the `vpmovmskb` and `popcnt` instructions to count the number of masked pixels. This change eliminated a couple of data transfer instructions and also simplified the coding of the `AvxPiCalcMeanUpdateSums` macro. Following the main processing loop, a `vextracti128` instruction is now used in the sequence of instructions that calculates the final value of `SumMaskedPixels`, as illustrated in Figure 15-5. The last change involves the `vcvtsi2sd` instruction, which requires two source operands. Like all other x86-AVX scalar double-precision floating-point instructions, the upper quadword of the first source operand is copied to the upper quadword of the destination operand. The second source operand contains the signed integer value that is converted to double-precision floating-point. This result is saved to the lower quadword of the destination operand. Output 15-4 shows the results of `AvxPackedIntegerThreshold`.

Initial value of SumMaskedPixels (8 doublewords)

1200	520	750	210	425	1475	330	940	ymm4
------	-----	-----	-----	-----	------	-----	-----	------

vextracti128 xmm0,ymm4,1

0	0	0	0	1200	520	750	210	ymm0
---	---	---	---	------	-----	-----	-----	------

vpadd xmm1,xmm0,xmm4

0	0	0	0	1625	1995	1080	1150	ymm1
---	---	---	---	------	------	------	------	------

vphadd xmm2,xmm1,xmm7

0	0	0	0	0	0	3620	2230	ymm2
---	---	---	---	---	---	------	------	------

vphadd xmm3,xmm2,xmm7

0	0	0	0	0	0	0	5850	ymm3
---	---	---	---	---	---	---	------	------

vmovd edx,ymm3

5850	edx
------	-----

Note: Register XMM7 contains all zeros.

Figure 15-5. Instruction sequence used to calculate the final value of SumMaskedPixels

Output 15-4. Sample Program AvxPackedIntegerThreshold

Results for AvxPackedIntegerThreshold

	C++	X86-AVX

SumPixelsMasked:	23813043	23813043
NumPixelsMasked:	138220	138220
MeanPixelsMasked:	172.283628	172.283628

Benchmark times saved to file __AvxPackedImageThresholdTimed.csv

Table 15-2 presents some timing measurements for the C++ and x86-AVX assembly language versions of the thresholding algorithms. It also contains timing measurements for the x86-SSE implementation of the algorithm that were reported in Table 10-2.

Table 15-2. Mean Execution Times (in Microseconds) of Image-Thresholding Algorithms Using *TestImage2.bmp*

CPU	C++	X86-AVX	X86-SSE
Intel Core i7-4770	518	39	49
Intel Core i7-4600U	627	50	60

Summary

This chapter illustrated how to use the packed integer capabilities of x86-AVX. You learned how to perform basic arithmetic operations using 256-bit wide packed integer operands. You also examined a couple of sample programs that employed the x86-AVX instruction set to carry out common image-processing techniques. The sample programs in this chapter and the two previous chapters accentuated many of the differences between x86-SSE and x86-AVX when working with packed integer, packed floating-point, and scalar floating-point operands. In the next chapter, you learn how to exploit some of the new instructions that were introduced with AVX2 and its concomitant feature set extensions.



X86-AVX Programming - New Instructions

In the previous three chapters, you learned how to manipulate scalar floating-point, packed floating-point, and packed integer operands using the x86-AVX instruction set. In this chapter you how to use some of the new programming features included with x86-AVX. The chapter begins with a sample program that illustrates the use of the `cpuid` instruction, which can be used to determine if the processor supports x86-SSE, x86-AVX, or a specific instruction-group feature extension. This is followed by collection of sample programs that explain how to use x86-AVX's advanced data-manipulation instructions. The final section of this chapter describes some of the x86's new general-purpose register instructions.

Detecting Processor Features (CPUID)

When writing software that exploits an x86 processor feature extension such as x86-SSE, x86-AVX, or one of the instruction group enhancements, you should never assume that the corresponding instruction set is available based on the processor's microarchitecture, model number, or brand name. You should always test for a specific feature using the `cpuid` (CPU Identification) instruction. The sample program of this section, called `AvxCpuid`, illustrates how to use this instruction to detect specific processor extensions and features. Listings 16-1 and 16-2 show the C++ and assembly language source for this sample program.

Listing 16-1. `AvxCpuid.cpp`

```
#include "stdafx.h"
#include "MiscDefs.h"
#include <memory.h>

// This structure is used to save cpuid instruction results. It must
// match the structure that's defined in AvxCpuid_.asm.
```

```

typedef struct
{
    Uint32 EAX;
    Uint32 EBX;
    Uint32 ECX;
    Uint32 EDX;
} CpuIdRegs;

// This structure contains status flags for cpuid reportable features
// used in this book.
typedef struct
{
    // General information
    Uint32 MaxEAX;        // Maximum EAX value supported by cpuid
    char VendorId[13];   // Processor vendor id string

    // Processor feature flags. Set to 'true' if feature extension
    // or instruction group is available for use.
    bool SSE;
    bool SSE2;
    bool SSE3;
    bool SSSE3;
    bool SSE4_1;
    bool SSE4_2;
    bool AVX;
    bool AVX2;
    bool F16C;
    bool FMA;
    bool POPCNT;
    bool BMI1;
    bool BMI2;
    bool LZCNT;
    bool MOVBE;

    // OS enabled feature information
    bool OSXSAVE;        // True if XSAVE feature set is enabled by the OS
    bool SSE_STATE;     // True if XMM state is enabled by the OS
    bool AVX_STATE;     // True if YMM state is enabled by the OS
} CpuIdFeatures;

extern "C" Uint32 CpuId(Uint32 r_eax, Uint32 r_ecx, CpuIdRegs* out);
extern "C" void Xgetbv_(Uint32 r_ecx, Uint32* r_eax, Uint32* r_edx);

// This function will not work on older CPUs, especially
// those introduced before 2006. It has been tested using
// only Windows 7 (SP1) and Windows 8.1.

```

```

void GetCpuidFeatures(CpuidFeatures* cf)
{
    CpuidRegs r_out;

    memset(cf, 0, sizeof(CpuidFeatures));

    // Get MaxEAX and VendorID
    Cpuid_(0, 0, &r_out);
    cf->MaxEAX = r_out.EAX;
    *(UInt32*)(cf->VendorId + 0) = r_out.EBX;
    *(UInt32*)(cf->VendorId + 4) = r_out.EDX;
    *(UInt32*)(cf->VendorId + 8) = r_out.ECX;
    cf->VendorId[12] = '\0';

    // Quit if processor is too old
    if (cf->MaxEAX < 10)
        return;

    // Get CPUID.01H feature flags
    Cpuid_(1, 0, &r_out);
    UInt32 cpuid01_ecx = r_out.ECX;
    UInt32 cpuid01_edx = r_out.EDX;

    // Get CPUID (EAX = 07H, ECX = 00H) feature flags
    Cpuid_(7, 0, &r_out);
    UInt32 cpuid07_ebx = r_out.EBX;

    // CPUID.01H:EDX.SSE[bit 25]
    cf->SSE = (cpuid01_edx & (0x1 << 25)) ? true : false;

    // CPUID.01H:EDX.SSE2[bit 26]
    if (cf->SSE)
        cf->SSE2 = (cpuid01_edx & (0x1 << 26)) ? true : false;

    // CPUID.01H:ECX.SSE3[bit 0]
    if (cf->SSE2)
        cf->SSE3 = (cpuid01_ecx & (0x1 << 0)) ? true : false;

    // CPUID.01H:ECX.SSSE3[bit 9]
    if (cf->SSE3)
        cf->SSSE3 = (cpuid01_ecx & (0x1 << 9)) ? true : false;

    // CPUID.01H:ECX.SSE4.1[bit 19]
    if (cf->SSSE3)
        cf->SSE4_1 = (cpuid01_ecx & (0x1 << 19)) ? true : false;
}

```

```

// CPUID.01H:ECX.SSE4.2[bit 20]
if (cf->SSE4_1)
    cf->SSE4_2 = (cpuid01_ecx & (0x1 << 20)) ? true : false;

// CPUID.01H:ECX.POPCNT[bit 23]
if (cf->SSE4_2)
    cf->POPCNT = (cpuid01_ecx & (0x1 << 23)) ? true : false;

// CPUID.01H:ECX.OSXSAVE[bit 27]
cf->OSXSAVE = (cpuid01_ecx & (0x1 << 27)) ? true : false;

// Test OSXSAVE status to verify XGETBV is enabled
if (cf->OSXSAVE)
{
    // Use XGETBV to obtain following information
    // XSAVE uses SSE state if (XCRO[1] == 1) is true
    // XSAVE uses AVX state if (XCRO[2] == 1) is true

    Uint32 xgetbv_eax, xgetbv_edx;

    Xgetbv(0, &xgetbv_eax, &xgetbv_edx);
    cf->SSE_STATE = (xgetbv_eax & (0x1 << 1)) ? true : false;
    cf->AVX_STATE = (xgetbv_eax & (0x1 << 2)) ? true : false;

    // Is SSE and AVX state information supported by the OS?
    if (cf->SSE_STATE && cf->AVX_STATE)
    {
        // CPUID.01H:ECX.AVX[bit 28] = 1
        cf->AVX = (cpuid01_ecx & (0x1 << 28)) ? true : false;

        if (cf->AVX)
        {
            // CPUID.01H:ECX.F16C[bit 29]
            cf->F16C = (cpuid01_ecx & (0x1 << 29)) ? true : false;

            // CPUID.01H:ECX.FMA[bit 12]
            cf->FMA = (cpuid01_ecx & (0x1 << 12)) ? true : false;

            // CPUID.(EAX = 07H, ECX = 00H):EBX.AVX2[bit 5]
            cf->AVX2 = (cpuid07_ebx & (0x1 << 5)) ? true : false;
        }
    }
}
}

```



```

// CPUID.(EAX = 07H, ECX = 00H):EBX.BMI1[bit 3]
cf->BMI1 = (cpuid07_ebx & (0x1 << 3)) ? true : false;

// CPUID.(EAX = 07H, ECX = 00H):EBX.BMI2[bit 8]
cf->BMI2 = (cpuid07_ebx & (0x1 << 8)) ? true : false;

// CPUID.80000001H:ECX.LZCNT[bit 5]
Cpuid_(0x80000001, 0, &r_out);
cf->LZCNT = (r_out.ECX & (0x1 << 5)) ? true : false;

// Get MOVBE
// CPUID.01H:ECX.MOVBE[bit 22]
cf->MOVBE = cpuid01_ecx & (0x1 << 22) ? true : false;
}

int _tmain(int argc, _TCHAR* argv[])
{
    CpuIdFeatures cf;

    GetCpuIdFeatures(&cf);
    printf("Results for AvxCpuId\n");
    printf("MaxEAX:    %d\n", cf.MaxEAX);
    printf("VendorId:    %s\n", cf.VendorId);
    printf("SSE:         %d\n", cf.SSE);
    printf("SSE2:        %d\n", cf.SSE2);
    printf("SSE3:        %d\n", cf.SSE3);
    printf("SSSE3:       %d\n", cf.SSSE3);
    printf("SSE4_1:      %d\n", cf.SSE4_1);
    printf("SSE4_2:      %d\n", cf.SSE4_2);
    printf("POPCNT:      %d\n", cf.POPCNT);
    printf("AVX:         %d\n", cf.AVX);
    printf("F16C:        %d\n", cf.F16C);
    printf("FMA:         %d\n", cf.FMA);
    printf("AVX2:        %d\n", cf.AVX2);
    printf("BMI1         %d\n", cf.BMI1);
    printf("BMI2         %d\n", cf.BMI2);
    printf("LZCNT        %d\n", cf.LZCNT);
    printf("MOVBE        %d\n", cf.MOVBE);
    printf("\n");
    printf("OSXSAVE      %d\n", cf.OSXSAVE);
    printf("SSE_STATE    %d\n", cf.SSE_STATE);
    printf("AVX_STATE    %d\n", cf.AVX_STATE);

    return 0;
}

```

Listing 16-2. AvxCpuid_.asm

```

.model flat,c

; This structure must match the structure that's defined
; in AvxCpuid.cpp

CpuidRegs struct
RegEAX      dword ?
RegEBX      dword ?
RegECX      dword ?
RegEDX      dword ?
CpuidRegs   ends
.code

; extern "C" UInt32 Cpuid_(UInt32 r_eax, UInt32 r_ecx, CpuidRegs* r_out);
;
; Description: The following function uses the CPUID instruction to
;              query processor identification and feature information.
;
; Returns:     eax == 0      Unsupported CPUID leaf
;              eax != 0     Supported CPUID leaf
;
;              The return code is valid only if r_eax <= MaxEAX.

Cpuid_ proc
    push ebp
    mov ebp,esp
    push ebx
    push esi

; Load eax and ecx with provided values, then use cpuid
    mov eax,[ebp+8]
    mov ecx,[ebp+12]
    cpuid

; Save results
    mov esi,[ebp+16]
    mov [esi+CpuidRegs.RegEAX],eax
    mov [esi+CpuidRegs.RegEBX],ebx
    mov [esi+CpuidRegs.RegECX],ecx
    mov [esi+CpuidRegs.RegEDX],edx

; Test for unsupported CPUID leaf
    or eax,ebx
    or ecx,edx
    or eax,ecx                                ;eax = return code

```

```

        pop esi
        pop ebx
        pop ebp
        ret
Cpuid_ endp

; extern "C" void Xgetbv_(UInt32 r_ecx, UInt32* r_eax, UInt32* r_edx);
;
; Description: The following function uses the XGETBV instruction to
;              obtain the contents of the extended control register
;              that's specified by r_ecx.
;
; Notes:      A processor exception will occur if r_ecx is invalid
;              or if the XSAVE feature set is disabled.

Xgetbv_ proc
    push ebp
    mov ebp,esp

    mov ecx,[ebp+8]                ;ecx = extended control reg
    xgetbv

    mov ecx,[ebp+12]
    mov [ecx],eax                 ;save result (low dword)
    mov ecx,[ebp+16]
    mov [ecx],edx                 ;save result (high dword)

    pop ebp
    ret
Xgetbv_ endp
end

```

Before examining the source code, you need to understand the basics of how the `cpuid` instruction works. Prior to using this instruction, register EAX must be loaded with a “leaf” value that specifies what type of information the `cpuid` instruction should return. A second or “sub-leaf” value also may be required in register ECX depending on the leaf value in EAX. The `cpuid` instruction returns its results in registers EAX, EBX, ECX, and EDX. The sample program of this section focuses on using the `cpuid` instruction to detect architectural features and instruction groups that are allied with this book’s content. You should refer to the Intel or AMD reference manuals and application notes listed in Appendix C if you’re interested in learning how to use the `cpuid` instruction to identify additional processor features and hardware capabilities.

Toward the top of the `AvxCpuid.cpp` file (see Listing 16-1), two C++ structures are declared. The first structure is called `CpuidRegs` and is used to save the results returned by the `cpuid` instruction. The second structure, named `CpuidFeatures`, contains various flags that indicate whether or not a particular processor feature is available for use.

Following the structure declarations are two declaration statements for the assembly language functions `Cpuid_` and `Xgetbv_`, which are used to execute the `cpuid` and `xgetbv` (Get Value of Extended Control Register) instructions, respectively.

In the function `GetCpuidFeatures`, the statement `Cpuid_(0, 0, &r_out)` determines the maximum EAX value that is supported by the `cpuid` instruction. The first two arguments of `Cpuid_` are used to initialize registers EAX and ECX prior to execution of the `cpuid` instruction; the third argument designates a `CpuidRegs` structure for the results from `cpuid`. Note that in the function `GetCpuidFeatures`, the value supplied for register ECX is ignored by the `cpuid` instruction, except when EAX is equal to seven. Upon return from `Cpuid_`, `r_out.EAX` contains the maximum allowable EAX value supported by the `cpuid` instruction, and `r_out.EBX`, `r_out.ECX`, and `r_out.EDX` comprise a processor vendor ID string. All of these values are saved to the specified `CpuidFeatures` structure.

In order to keep the remaining logic reasonable, the `GetCpuidFeatures` function terminates if it detects that it's running on an older processor. Next, the function `Cpuid_` is called twice to obtain the necessary `cpuid` feature status flags. The `cpuid` status flags related to x86-SSE are then decoded and saved.

An application program can use the computational resources of x86-AVX only if it's supported by *both* the processor and its host operating system. The processor's `OSXSAVE` flag indicates whether or not the operating system saves x86-AVX state information during a task switch. An `OSXSAVE` flag state of true also indicates that it's safe to use the `xgetbv` instruction in order to determine operating system state support for the XMM and YMM registers. Once this information is established, the `GetCpuidFeatures` function proceeds to decode the `cpuid` status flags related to x86-AVX and its concomitant feature extensions. It also ascertains the presence of several instruction groups whose availability is independent of operating system state support for x86-AVX.

Near the top of the `AvxCpuid_.asm` file (see Listing 16-2) is the assembly language version of the `CpuidRegs` structure. The code for function `Cpuid_` is straightforward: It loads registers EAX and ECX with the provided argument values, executes the `cpuid` instruction, and saves the results to the designated location in memory. Note that if the leaf value supplied in EAX is invalid and less than or equal to the maximum leaf value supported by the processor, the `cpuid` instruction returns zeroes in registers EAX, EBX, ECX, and EDX.

The code for function `Xgetbv_` is also straight forward. It's important to note, however, that the processor will generate an exception if the extended control register that's specified in `r_ecx` is invalid or if the processor's `OSXSAVE` status flag is set to false. This explains why `OSXSAVE` was tested in the C++ function `GetCpuidFeatures` prior to calling `Xgetbv_`. Table 16-1 summarizes the results generated by the `AvxCpuid` sample program using several different processors.

Table 16-1. Summary of Results from Sample Program *AvxCpuId*

Feature	E6700	Q9650	i3-2310M	i7-4600U	i7-4770
MaxEAX	10	13	13	13	13
VendorId	GenuineIntel	GenuineIntel	GenuineIntel	GenuineIntel	GenuineIntel
SSE	1	1	1	1	1
SSE2	1	1	1	1	1
SSE3	1	1	1	1	1
SSSE3	1	1	1	1	1
SSE4_1	0	1	1	1	1
SSE4_2	0	0	1	1	1
POPCNT	0	0	1	1	1
AVX	0	0	1	1	1
F16C	0	0	0	1	1
FMA	0	0	0	1	1
AVX2	0	0	0	1	1
BMI1	0	0	0	1	1
BMI2	0	0	0	1	1
LZCNT	0	0	0	1	1
MOVBE	0	0	0	1	1

Data-Manipulation Instructions

X86-AVX includes a variety of enhanced data-manipulation instructions that can be used with either packed floating-point or packed integer operands. Many of these instructions are structured to be a more efficient substitute for an existing x86-SSE instruction or sequence of instructions. Enhanced data manipulations include broadcast, blend, permute, and gather operations. The sample code in this section demonstrates how to use representative instructions from each of these groups.

Data Broadcast

The first sample program of this section, named *AvxBroadcast*, demonstrates how to use some of x86-AVX's integer and floating-point broadcast instructions. A broadcast instruction copies a single data value to each element of the destination operand. These instructions are often used to create packed constant values. Listings 16-3 and 16-4 show the C++ and assembly language source for sample program *AvxBroadcast*.

Listing 16-3. AvxBroadcast.cpp

```

#include "stdafx.h"
#include "XmmVal.h"
#include "YmmVal.h"
#include <memory.h>
#define _USE_MATH_DEFINES
#include <math.h>

// The order of values in the following enum must match the table
// that's defined in AvxBroadcast.asm.
enum Brop : unsigned int
{
    Byte, Word, Dword, Qword
};

extern "C" void AvxBroadcastIntegerYmm_(YmmVal* des, const XmmVal* src, Brop op);
extern "C" void AvxBroadcastFloat_(YmmVal* des, float val);
extern "C" void AvxBroadcastDouble_(YmmVal* des, double val);

void AvxBroadcastInteger(void)
{
    char buff[512];
    __declspec(align(16)) XmmVal src;
    __declspec(align(32)) YmmVal des;

    memset(&src, 0, sizeof(XmmVal));

    src.i16[0] = 42;
    AvxBroadcastIntegerYmm_(&des, &src, Brop::Word);

    printf("\nResults for AvxBroadcastInteger() - Brop::Word\n");
    printf("src   %s\n", src.ToString_i16(buff, sizeof(buff)));
    printf("des lo %s\n", des.ToString_i16(buff, sizeof(buff), false));
    printf("des hi %s\n", des.ToString_i16(buff, sizeof(buff), true));

    src.i64[0] = -80;
    AvxBroadcastIntegerYmm_(&des, &src, Brop::Qword);

    printf("\nResults for AvxBroadcastInteger() - Brop::Qword\n");
    printf("src: %s\n", src.ToString_i64(buff, sizeof(buff)));
    printf("des lo: %s\n", des.ToString_i64(buff, sizeof(buff), false));
    printf("des hi: %s\n", des.ToString_i64(buff, sizeof(buff), true));
}

```

```

void AvxBroadcastFloatingPoint(void)
{
    char buff[512];
    __declspec(align(32)) YmmVal des;

    AvxBroadcastFloat_(&des, (float)M_SQRT2);
    printf("\nResults for AvxBroadcastFloatingPoint() - float\n");
    printf("des lo: %s\n", des.ToString_r32(buff, sizeof(buff), false));
    printf("des hi: %s\n", des.ToString_r32(buff, sizeof(buff), true));

    AvxBroadcastDouble_(&des, M_PI);
    printf("\nResults for AvxBroadcastFloatingPoint() - double\n");
    printf("des lo: %s\n", des.ToString_r64(buff, sizeof(buff), false));
    printf("des hi: %s\n", des.ToString_r64(buff, sizeof(buff), true));
}

int _tmain(int argc, _TCHAR* argv[])
{
    AvxBroadcastInteger();
    AvxBroadcastFloatingPoint();
    return 0;
}

```

Listing 16-4. AvxBroadcast_.asm

```

.model flat,c
.code

; extern "C" void AvxBroadcastIntegerYmm_(YmmVal* des, const XmmVal* src,
Brop op);
;
; Description: The following function demonstrates use of the
;               vpbroadcastX instruction.
;
; Requires:     AVX2

AvxBroadcastIntegerYmm_ proc
    push ebp
    mov ebp,esp

; Make sure op is valid
    mov eax,[ebp+16]           ;eax = op
    cmp eax,BropTableCount
    jae BadOp                 ;jump if op is invalid

```

```

; Load parameters and jump to specified instruction
mov ecx,[ebp+8]           ;ecx = des
mov edx,[ebp+12]        ;edx = src
vmovdq xmm0,xmmword ptr [edx] ;xmm0 = broadcast value (low item)
mov edx,[BropTable+eax*4]
jmp edx

```

```

; Perform byte broadcast

```

```

BropByte:
vpbroadcastb ymm1,xmm0
vmovdq ymmword ptr [ecx],ymm1
vzeroupper
pop ebp
ret

```

```

; Perform word broadcast

```

```

BropWord:
vpbroadcastw ymm1,xmm0
vmovdq ymmword ptr [ecx],ymm1
vzeroupper
pop ebp
ret

```

```

; Perform dword broadcast

```

```

BropDword:
vpbroadcastd ymm1,xmm0
vmovdq ymmword ptr [ecx],ymm1
vzeroupper
pop ebp
ret

```

```

; Perform qword broadcast

```

```

BropQword:
vpbroadcastq ymm1,xmm0
vmovdq ymmword ptr [ecx],ymm1
vzeroupper
pop ebp
ret

```

```

BadOp: pop ebp
ret

```

```

; The order of values in the following table must match the enum Brop
; that's defined in AvxBroadcast.cpp.

```

```

align 4
BropTable dword BropByte, BropWord, BropDword, BropQword
BropTableCount equ ($ - BropTable) / size dword

```



```

AvxBroadcastIntegerYmm_ endp

; extern "C" void AvxBroadcastFloat_(YmmVal* des, float val);
;
; Description: The following function demonstrates use of the
;               vbroadcastss instruction.
;
; Requires:    AVX

AvxBroadcastFloat_ proc
    push ebp
    mov ebp,esp

; Broadcast val to all elements of des
    mov eax,[ebp+8]
    vbroadcastss ymm0,real4 ptr [ebp+12]
    vmovaps ymmword ptr [eax],ymm0

    vzeroupper
    pop ebp
    ret
AvxBroadcastFloat_ endp

; extern "C" void AvxBroadcastDouble_(YmmVal* des, double val);
;
; Description: The following function demonstrates use of the
;               vbroadcastsd instruction.
;
; Requires:    AVX

AvxBroadcastDouble_ proc
    push ebp
    mov ebp,esp

; Broadcast val to all elements of des.
    mov eax,[ebp+8]
    vbroadcastsd ymm0,real8 ptr [ebp+12]
    vmovapd ymmword ptr [eax],ymm0

    vzeroupper
    pop ebp
    ret
AvxBroadcastDouble_ endp
end

```

The C++ file `AvxBroadcast.cpp` (see Listing 16-3) includes two functions that initialize test cases for integer and floating-point broadcast operations. The first function, `AvxBroadcastInteger`, invokes the assembly language function `AvxBroadcastInteger_` to illustrate integer broadcasts using words and quadwords. The second function, `AvxBroadcastFloat`, employs two assembly language functions that demonstrate broadcast operations using single-precision and double-precision floating-point values.

The assembly language file `AvxBroadcast_.asm` (see Listing 16-4) contains the functions that perform the actual broadcast operations. The function named `AvxBroadcastInteger_` illustrates use of the `vpbroadcast(b| w| d| q)` (byte, word, doubleword, and quadword) instructions. The source operand for these instructions must be an XMM register (the low-order element) or a memory location. The destination operand can be either an XMM or YMM register. Besides the `vpbroadcast(b| w| d| q)` instructions, the x86-AVX instruction set also includes a `vbroadcasti128` instruction, which broadcasts 128 bits of integer data from a memory location to the lower and upper 128 bits of a YMM register.

The functions `AvxBroadcastFloat_` and `AvxBroadcastDouble_` illustrate use of the `vbroadcastss` and `vbroadcastsd` (Broadcast Floating-Point Data) instructions. The source operands for these instructions must be a memory location or an XMM register. Note that AVX2 is required to use these instructions with an XMM source operand. The destination operand of the `vbroadcastss` instruction can be an XMM or YMM register; the destination operand of the `vbroadcastsd` instruction must be a YMM register. The x86-AVX instruction set also supports a 128-bit broadcast instruction named `vbroadcastf128` for floating-point data. Output 16-1 shows the results for sample program `AvxBroadcast`.

Output 16-1. Sample Program `AvxBroadcast`

Results for `AvxBroadcastInteger()` - `Brop::Word`

src	42	0	0	0		0	0	0	0
des lo	42	42	42	42		42	42	42	42
des hi	42	42	42	42		42	42	42	42

Results for `AvxBroadcastInteger()` - `Brop::Qword`

src:	-80		0
des lo:	-80		-80
des hi:	-80		-80

Results for `AvxBroadcastFloatingPoint()` - `float`

des lo:	1.414214	1.414214		1.414214	1.414214
des hi:	1.414214	1.414214		1.414214	1.414214

Results for `AvxBroadcastFloatingPoint()` - `double`

des lo:	3.141592653590		3.141592653590
des hi:	3.141592653590		3.141592653590

Data Blend

A data blend operation conditionally copies the elements of two packed source operands to a packed destination operand using a control value that specifies which elements to copy. The next sample program is called `AvxBBlend` and it demonstrates the use of two x86-AVX blend instructions using packed floating-point and packed integer operands. Listings 16-5 and 16-6 show the C++ and assembly language source code for `AvxBBlend`.

Listing 16-5. `AvxBBlend.cpp`

```
#include "stdafx.h"
#include "YmmVal.h"

extern "C" void AvxBBlendFloat_(YmmVal* des, YmmVal* src1, YmmVal* src2,
YmmVal* src3);
extern "C" void AvxBBlendByte_(YmmVal* des, YmmVal* src1, YmmVal* src2,
YmmVal* src3);

void AvxBBlendFloat(void)
{
    char buff[256];
    const Uint32 select1 = 0x00000000;
    const Uint32 select2 = 0x80000000;
    __declspec(align(32)) YmmVal des, src1, src2, src3;

    src1.r32[0] = 100.0f;      src2.r32[0] = -1000.0f;
    src1.r32[1] = 200.0f;      src2.r32[1] = -2000.0f;
    src1.r32[2] = 300.0f;      src2.r32[2] = -3000.0f;
    src1.r32[3] = 400.0f;      src2.r32[3] = -4000.0f;
    src1.r32[4] = 500.0f;      src2.r32[4] = -5000.0f;
    src1.r32[5] = 600.0f;      src2.r32[5] = -6000.0f;
    src1.r32[6] = 700.0f;      src2.r32[6] = -7000.0f;
    src1.r32[7] = 800.0f;      src2.r32[7] = -8000.0f;

    src3.u32[0] = select2;
    src3.u32[1] = select2;
    src3.u32[2] = select1;
    src3.u32[3] = select2;
    src3.u32[4] = select1;
    src3.u32[5] = select1;
    src3.u32[6] = select2;
    src3.u32[7] = select1;

    AvxBBlendFloat_(&des, &src1, &src2, &src3);

    printf("\nResults for AvxBBlendFloat()\n");
    printf("src1 lo: %s\n", src1.ToString_r32(buff, sizeof(buff), false));
    printf("src1 hi: %s\n", src1.ToString_r32(buff, sizeof(buff), true));
}
```

```

    printf("src2 lo: %s\n", src2.ToString_r32(buff, sizeof(buff), false));
    printf("src2 hi: %s\n", src2.ToString_r32(buff, sizeof(buff), true));
    printf("\n");
    printf("src3 lo: %s\n", src3.ToString_x32(buff, sizeof(buff), false));
    printf("src3 hi: %s\n", src3.ToString_x32(buff, sizeof(buff), true));
    printf("\n");
    printf("des lo: %s\n", des.ToString_r32(buff, sizeof(buff), false));
    printf("des hi: %s\n", des.ToString_r32(buff, sizeof(buff), true));
}

```

```
void AvxBBlendByte(void)
```

```

{
    char buff[256];
    __declspec(aligned(32)) YmmVal des, src1, src2, src3;

    // Control values required to perform doubleword blend
    // using vpbldvb instruction
    const UInt32 select1 = 0x00000000;    // select src1
    const UInt32 select2 = 0x80808080;    // select src2

    src1.i32[0] = 100;    src2.i32[0] = -1000;
    src1.i32[1] = 200;    src2.i32[1] = -2000;
    src1.i32[2] = 300;    src2.i32[2] = -3000;
    src1.i32[3] = 400;    src2.i32[3] = -4000;
    src1.i32[4] = 500;    src2.i32[4] = -5000;
    src1.i32[5] = 600;    src2.i32[5] = -6000;
    src1.i32[6] = 700;    src2.i32[6] = -7000;
    src1.i32[7] = 800;    src2.i32[7] = -8000;

    src3.u32[0] = select1;
    src3.u32[1] = select1;
    src3.u32[2] = select2;
    src3.u32[3] = select1;
    src3.u32[4] = select2;
    src3.u32[5] = select2;
    src3.u32[6] = select1;
    src3.u32[7] = select2;

    AvxBBlendByte_(&des, &src1, &src2, &src3);

    printf("\nResults for AvxBBlendByte() - doublewords\n");
    printf("src1 lo: %s\n", src1.ToString_i32(buff, sizeof(buff), false));
    printf("src1 hi: %s\n", src1.ToString_i32(buff, sizeof(buff), true));
    printf("src2 lo: %s\n", src2.ToString_i32(buff, sizeof(buff), false));
    printf("src2 hi: %s\n", src2.ToString_i32(buff, sizeof(buff), true));
    printf("\n");
    printf("src3 lo: %s\n", src3.ToString_x32(buff, sizeof(buff), false));
}

```

```

printf("src3 hi: %s\n", src3.ToString_x32(buff, sizeof(buff), true));
printf("\n");
printf("des lo: %s\n", des.ToString_i32(buff, sizeof(buff), false));
printf("des hi: %s\n", des.ToString_i32(buff, sizeof(buff), true));
}

int _tmain(int argc, _TCHAR* argv[])
{
    AvxBleedFloat();
    AvxBleedByte();
    return 0;
}

```

Listing 16-6. AvxBleed_.asm

```

.model flat,c
.code

; extern "C" void AvxBleedFloat_(YmmVal* des, YmmVal* src1, YmmVal* src2,
YmmVal* src3);
;
; Description: The following function demonstrates use of the vblendvps
;               instruction using YMM registers.
;
; Requires:     AVX

AvxBleedFloat_ proc
    push ebp
    mov  ebp,esp

; Load argument values
    mov  eax,[ebp+12]           ;eax = ptr to src1
    mov  ecx,[ebp+16]           ;ecx = ptr to src2
    mov  edx,[ebp+20]           ;edx = ptr to src3

    vmovaps ymm1,ymmword ptr [eax]   ;ymm1 = src1
    vmovaps ymm2,ymmword ptr [ecx]   ;ymm2 = src2
    vmovdqa ymm3,ymmword ptr [edx]   ;ymm3 = src3

; Perform variable SPFP blend
    vblendvps ymm0,ymm1,ymm2,ymm3    ;ymm0 = blend result
    mov  eax,[ebp+8]
    vmovaps ymmword ptr [eax],ymm0   ;save blend result

    vzeroupper
    pop  ebp
    ret
AvxBleedFloat_ endp

```

```

; extern "C" void AvxBBlendByte_(YmmVal* des, YmmVal* src1, YmmVal* src2,
YmmVal* src3);
;
; Description: The following function demonstrates use of the vpbblendvb
; instruction.
;
; Requires: AVX2

AvxBBlendByte_ proc
    push ebp
    mov ebp,esp

; Load argument values
    mov eax,[ebp+12]           ;eax = ptr to src1
    mov ecx,[ebp+16]           ;ecx = ptr to src2
    mov edx,[ebp+20]           ;edx = ptr to src3

    vmovdqa ymm1,ymmword ptr [eax] ;ymm1 = src1
    vmovdqa ymm2,ymmword ptr [ecx] ;ymm2 = src2
    vmovdqa ymm3,ymmword ptr [edx] ;ymm3 = src3

; Perform variable byte blend
    vpbblendvb ymm0,ymm1,ymm2,ymm3 ;ymm0 = blend result
    mov eax,[ebp+8]
    vmovdqa ymmword ptr [eax],ymm0 ;save blend result
    vzeroupper
    pop ebp
    ret
AvxBBlendByte_ endp
end

```

The C++ file `AvxBBlend.cpp` (see Listing 16-5) contains a function named `AvxBBlendFloat` that initializes `YmmVal` variables `src1` and `src2` using single-precision floating-point values. It also initializes a third `YmmVal` instance named `src3` for use as a blend control value. The high-order bit of each doubleword element in `src3` specifies whether the corresponding element from `src1` (high-order bit = 0) or `src2` (high-order bit = 1) is copied to the destination operand. The three source operands are used by the `vblendvps` (Variable Blend Packed Single-Precision Floating-Point Values) instruction, which is executed by the assembly language function `AvxBBlendFloat_`. Following execution of this function, a series of `printf` statements displays the results.

The `AvxBBlend.cpp` file also contains a function named `AvxBBlendInt32`, which initializes `YmmVal` variables `src1` and `src2` in order to demonstrate a packed doubleword integer blend operation. This function also uses a third source operand to specify which source operand elements are copied to the destination operand. The values `src1`, `src2`, and `src3` are ultimately used by the `vpblendvb` (Variable Blend Packed Bytes) instruction, which is contained in the assembly language function `AvxBBlendInt32_`.

The `AvxBleedFloat_` function (see Listing 16-6) begins by loading argument values `src1`, `src2`, and `src3` into registers `YMM1`, `YMM2`, and `YMM3`, respectively. It then executes a `vblendvps ymm0,ymm1,ymm2,ymm3` instruction to carry out the floating-point blend operation, as shown in Figure 16-1. The `vblendvps` instruction and its double-precision counterpart `vblendvpd` are examples of x86-AVX instructions that require three source operands. Floating-point blend operations using an immediate control value are possible with the `vblendps` and `vblendpd` instructions.

`vblendvps ymm0,ymm1,ymm2,ymm3`

	800.0	700.0	600.0	500.0	400.0	300.0	200.0	100.0	ymm 1
	-8000.0	-7000.0	-6000.0	-5000.0	-4000.0	-3000.0	-2000.0	-1000.0	ymm 2
	00000000	80000000	00000000	00000000	80000000	00000000	80000000	80000000	ymm 3
	800.0	-7000.0	600.0	500.0	-4000.0	300	-2000.0	-1000.0	ymm 0

Note: Each doubleword element of `YMM3` is a hexadecimal value.

Figure 16-1. Execution of the `vblendvps` instruction

X86-AVX includes several instructions that can be used to carry out integer blend operations. The `vblendw` (Blend Packed Words) and `vblendd` (Blend Packed Dwords) instructions perform packed integer blends using words and doublewords, respectively. Both of these instructions require an 8-bit immediate operand that specifies the blend control value.

The x86-AVX instruction set also includes the `vblendvb` instruction that blends bytes using a variable control value. This instruction uses the high-order bit of each byte in the third source operand to select a byte from one of the first two source operands. The `vblendvb` instruction can also be employed to blend words, doublewords, and quadwords if it's used with a suitable control value. For example, in order to blend doublewords, the `AvxBleedInt32_` function (see Listing 16-6) uses the control value `0x00000000` or `0x80808080` to select a doubleword element from the first or second source operand, respectively. Output 16-2 contains the results for sample program `AvxBleed`.

Output 16-2. Sample Program `AvxBleed`

```
Results for AvxBleedFloat()
src1 lo: 100.000000 200.000000 | 300.000000 400.000000
src1 hi: 500.000000 600.000000 | 700.000000 800.000000
src2 lo: -1000.000000 -2000.000000 | -3000.000000 -4000.000000
src2 hi: -5000.000000 -6000.000000 | -7000.000000 -8000.000000

src3 lo: 80000000 80000000 | 00000000 80000000
src3 hi: 00000000 00000000 | 80000000 00000000
```

```
des lo:  -1000.000000 -2000.000000 |  300.000000 -4000.000000
des hi:   500.000000  600.000000 | -7000.000000  800.000000
```

Results for AvxBlendByte() - doublewords

```
src1 lo:      100          200 |           300          400
src1 hi:      500          600 |           700          800
src2 lo:     -1000        -2000 |         -3000        -4000
src2 hi:     -5000        -6000 |         -7000        -8000
```

```
src3 lo: 00000000 00000000 | 80808080 00000000
src3 hi: 80808080 80808080 | 00000000 80808080
```

```
des lo:      100          200 |         -3000          400
des hi:     -5000        -6000 |           700        -8000
```

Data Permute

The x86-AVX instruction set includes several data permute instructions, which rearrange the elements of a packed data value according to a control value. The sample program of this section, named `AvxPermute`, explains how to use a few of these instructions.

Listings 16-7 and 16-8 present the source code for sample program `AvxPermute`.

Listing 16-7. `AvxPermute.cpp`

```
#include "stdafx.h"
#include "YmmVal.h"
#include <math.h>

extern "C" void AvxPermuteInt32_(YmmVal* des, YmmVal* src, YmmVal* ind);
extern "C" void AvxPermuteFloat_(YmmVal* des, YmmVal* src, YmmVal* ind);
extern "C" void AvxPermuteFloatI1_(YmmVal* des, YmmVal* src, YmmVal* ind);

void AvxPermuteInt32(void)
{
    __declspec(align(32)) YmmVal des, src, ind;

    src.i32[0] = 10;      ind.i32[0] = 3;
    src.i32[1] = 20;      ind.i32[1] = 7;
    src.i32[2] = 30;      ind.i32[2] = 0;
    src.i32[3] = 40;      ind.i32[3] = 4;
    src.i32[4] = 50;      ind.i32[4] = 6;
    src.i32[5] = 60;      ind.i32[5] = 6;
    src.i32[6] = 70;      ind.i32[6] = 1;
    src.i32[7] = 80;      ind.i32[7] = 2;

    AvxPermuteInt32_(&des, &src, &ind);
}
```



```

printf("\nResults for AvxPermuteInt32()\n");
for (int i = 0; i < 8; i++)
{
    printf("des[%d]: %5d  ", i, des.i32[i]);
    printf("ind[%d]: %5d  ", i, ind.i32[i]);
    printf("src[%d]: %5d  ", i, src.i32[i]);
    printf("\n");
}

void AvxPermuteFloat(void)
{
    __declspec(align(32)) YmmVal des, src, ind;

    // src1 indices must be between 0 and 7.
    src.r32[0] = 800.0f;    ind.i32[0] = 3;
    src.r32[1] = 700.0f;    ind.i32[1] = 7;
    src.r32[2] = 600.0f;    ind.i32[2] = 0;
    src.r32[3] = 500.0f;    ind.i32[3] = 4;
    src.r32[4] = 400.0f;    ind.i32[4] = 6;
    src.r32[5] = 300.0f;    ind.i32[5] = 6;
    src.r32[6] = 200.0f;    ind.i32[6] = 1;
    src.r32[7] = 100.0f;    ind.i32[7] = 2;

    AvxPermuteFloat_(&des, &src, &ind);

    printf("\nResults for AvxPermuteFloat()\n");
    for (int i = 0; i < 8; i++)
    {
        printf("des[%d]: %8.1f  ", i, des.r32[i]);
        printf("ind[%d]: %5d  ", i, ind.i32[i]);
        printf("src[%d]: %8.1f  ", i, src.r32[i]);
        printf("\n");
    }
}

void AvxPermuteFloatIl(void)
{
    __declspec(align(32)) YmmVal des, src, ind;

    // Lower lane
    src.r32[0] = sqrt(10.0f);    ind.i32[0] = 3;
    src.r32[1] = sqrt(20.0f);    ind.i32[1] = 2;
    src.r32[2] = sqrt(30.0f);    ind.i32[2] = 2;
    src.r32[3] = sqrt(40.0f);    ind.i32[3] = 0;

```

```

// Upper lane
src.r32[4] = sqrt(50.0f);      ind.i32[4] = 1;
src.r32[5] = sqrt(60.0f);      ind.i32[5] = 3;
src.r32[6] = sqrt(70.0f);      ind.i32[6] = 3;
src.r32[7] = sqrt(80.0f);      ind.i32[7] = 2;

AvxPermuteFloatIl_(&des, &src, &ind);

printf("\nResults for AvxPermuteFloatIl()\n");
for (int i = 0; i < 8; i++)
{
    if (i == 0)
        printf("Lower lane\n");
    else if (i == 4)
        printf("Upper lane\n");

    printf("des[%d]: %8.4f ", i, des.r32[i]);
    printf("ind[%d]: %5d ", i, ind.i32[i]);
    printf("src[%d]: %8.4f ", i, src.r32[i]);
    printf("\n");
}
}

int _tmain(int argc, _TCHAR* argv[])
{
    AvxPermuteInt32();
    AvxPermuteFloat();
    AvxPermuteFloatIl();
    return 0;
}

```

Listing 16-8. AvxPermute.asm

```

.model flat,c
.code

; extern "C" void AvxPermuteInt32_(YmmVal* des, YmmVal* src, YmmVal* ind);
;
; Description: The following function demonstrates use of the
;             vpermd instruction.
;
; Requires:   AVX2

AvxPermuteInt32_ proc
    push ebp
    mov ebp,esp

```

```

; Load argument values
    mov eax,[ebp+8]           ;eax = ptr to des
    mov ecx,[ebp+12]        ;ecx = ptr to src
    mov edx,[ebp+16]        ;edx = ptr to ind

; Perform dword permutation
    vmovdq ymm1,ymmword ptr [edx] ;ymm1 = ind
    vpermd ymm0,ymm1,ymmword ptr [ecx]
    vmovdq ymmword ptr [eax],ymm0 ;save result

    vzeroupper
    pop ebp
    ret
AvxPermuteInt32_ endp

; extern "C" void AvxPermuteFloat_(YmmVal* des, YmmVal* src, YmmVal* ind);
;
; Description: The following function demonstrates use of the
;               vpermps instruction.
;
; Requires:     AVX2

AvxPermuteFloat_ proc
    push ebp
    mov ebp,esp

; Load argument values
    mov eax,[ebp+8]           ;eax = ptr to des
    mov ecx,[ebp+12]        ;ecx = ptr to src
    mov edx,[ebp+16]        ;edx = ptr to ind

; Perform SPFP permutation
    vmovdq ymm1,ymmword ptr [edx] ;ymm1 = ind
    vpermps ymm0,ymm1,ymmword ptr [ecx]
    vmovaps ymmword ptr [eax],ymm0 ;save result

    vzeroupper
    pop ebp
    ret
AvxPermuteFloat_ endp

; extern "C" void AvxPermuteFloatIl_(YmmVal* des, YmmVal* src, YmmVal* ind);
;
; Description: The following function demonstrates use of the
;               vpermilps instruction.
;
; Requires:     AVX2

```

```

AvxPermuteFloatI1_ proc
    push ebp
    mov ebp,esp

; Load argument values
    mov eax,[ebp+8]           ;eax = ptr to des
    mov ecx,[ebp+12]        ;ecx = ptr to src
    mov edx,[ebp+16]        ;edx = ptr to ind

; Perform in-lane SPFP permutation. Note that the second source
; operand of vpermilps specifies the indices.
    vmovdqa ymm1,ymmword ptr [ecx] ;ymm1 = src
    vpermilps ymm0,ymm1,ymmword ptr [edx]
    vmovaps ymmword ptr [eax],ymm0 ;save result

    vzeroupper
    pop ebp
    ret
AvxPermuteFloatI1_ endp
end

```

The source code file `AvxPermute.cpp` (see Listing 16-7) includes a function named `AvxPermuteInt32` that initializes a test case in order to demonstrate a packed doubleword integer permutation. The variable `ind` contains a set of indices that specifies which elements from `src` are copied to `des`. For example, the statement `ind.i32[0] = 3` signifies that the permute operation should perform `des.i32[0] = src.i32[3]`. Each index in `ind` must lie between zero and seven. An index can be used more than once in `ind` in order to copy an element from `src` to multiple locations in `des`. The function `AvxPermuteFloat` is similar to `AvxPermuteInt32`, except that it establishes a test case for a packed single-precision floating-point permutation.

The source code file `AvxPermute.cpp` also contains a function named `AvxPermuteFloatI1`, which initializes the `YmmVal` variables `src` and `ind` for an in-lane permutation of a packed single-precision floating-point value. An in-lane permutation carries out its operations using two separate 128-bit lanes. The control indices for an in-lane permutation must range between zero and three, and each lane requires its own set of indices.

The assembly language file `AvxPermute_.asm` (see Listing 16-8) contains the `AvxPermuteInt32_` and `AvxPermuteFloat_` functions. These functions use the x86-AVX instructions `vpermd` and `vpermps` to carry out packed doubleword integer and single-precision floating-point permutations. Both instructions require the first source operand to contain the control indices; the second source operand contains the packed data value to permute. The `AvxPermute_.asm` file also includes the `AvxPermuteFloatI1_` function, which demonstrates use of the in-lane permutation instruction `vpermilps`. Note that for this instruction, the first source operand contains the packed data value to permute and the second source operand holds the control indices. Output 16-3 shows the results for sample program `AvxPermute`.

Output 16-3. Sample Program AvxPermute

Results for AvxPermuteInt32()

```

des[0]:  40  ind[0]:  3  src[0]:  10
des[1]:  80  ind[1]:  7  src[1]:  20
des[2]:  10  ind[2]:  0  src[2]:  30
des[3]:  50  ind[3]:  4  src[3]:  40
des[4]:  70  ind[4]:  6  src[4]:  50
des[5]:  70  ind[5]:  6  src[5]:  60
des[6]:  20  ind[6]:  1  src[6]:  70
des[7]:  30  ind[7]:  2  src[7]:  80

```

Results for AvxPermuteFloat()

```

des[0]:  500.0  ind[0]:  3  src[0]:  800.0
des[1]:  100.0  ind[1]:  7  src[1]:  700.0
des[2]:  800.0  ind[2]:  0  src[2]:  600.0
des[3]:  400.0  ind[3]:  4  src[3]:  500.0
des[4]:  200.0  ind[4]:  6  src[4]:  400.0
des[5]:  200.0  ind[5]:  6  src[5]:  300.0
des[6]:  700.0  ind[6]:  1  src[6]:  200.0
des[7]:  600.0  ind[7]:  2  src[7]:  100.0

```

Results for AvxPermuteFloatIl()

Lower lane

```

des[0]:  6.3246  ind[0]:  3  src[0]:  3.1623
des[1]:  5.4772  ind[1]:  2  src[1]:  4.4721
des[2]:  5.4772  ind[2]:  2  src[2]:  5.4772
des[3]:  3.1623  ind[3]:  0  src[3]:  6.3246

```

Upper lane

```

des[4]:  7.7460  ind[4]:  1  src[4]:  7.0711
des[5]:  8.9443  ind[5]:  3  src[5]:  7.7460
des[6]:  8.9443  ind[6]:  3  src[6]:  8.3666
des[7]:  8.3666  ind[7]:  2  src[7]:  8.9443

```

Data Gather

The final sample program of this section, `AvxGather`, illuminates use of the x86-AVX gather instructions. A gather instruction conditionally copies elements from an array in memory to an XMM or YMM register. Each gather instruction requires a set of indices and a control mask that specifies the exact elements to copy from the array. The C++ and assembly language source for sample program `AvxGather` are shown in Listings 16-9 and 16-10.

Listing 16-9. AvxGather.cpp

```

#include "stdafx.h"
#include "XmmVal.h"
#include "YmmVal.h"
#include <stdlib.h>

extern "C" void AvxGatherFloat_(YmmVal* des, YmmVal* indices, YmmVal* mask,
const float* x);
extern "C" void AvxGatherI64_(YmmVal* des, XmmVal* indices, YmmVal* mask,
const Int64* x);

void AvxGatherFloatPrint(const char* msg, YmmVal& des, YmmVal& indices,
YmmVal& mask)
{
    printf("\n%s\n", msg);

    for (int i = 0; i < 8; i++)
    {
        printf("ElementID: %d ", i);
        printf("des: %8.1f ", des.r32[i]);
        printf("indices: %4d ", indices.i32[i]);
        printf("mask: 0x%08X\n", mask.i32[i]);
    }
}

void AvxGatherI64Print(const char* msg, YmmVal& des, XmmVal& indices,
YmmVal& mask)
{
    printf("\n%s\n", msg);

    for (int i = 0; i < 4; i++)
    {
        printf("ElementID: %d ", i);
        printf("des: %8lld ", des.i64[i]);
        printf("indices: %4d ", indices.i32[i]);
        printf("mask: 0x%016lX\n", mask.i64[i]);
    }
}

void AvxGatherFloat(void)
{
    const int merge_no = 0;
    const int merge_yes = 0x80000000;
    const int n = 15;
    float x[n];
    __declspec(align(32)) YmmVal des;
    __declspec(align(32)) YmmVal indices;
    __declspec(align(32)) YmmVal mask;

```

```

// Initialize the test array
srand(22);
for (int i = 0; i < n; i++)
    x[i] = (float)(rand() % 1000);

// Load des with initial values
for (int i = 0; i < 8; i++)
    des.r32[i] = -1.0f;

// Initialize the indices
indices.i32[0] = 2;
indices.i32[1] = 1;
indices.i32[2] = 6;
indices.i32[3] = 5;
indices.i32[4] = 4;
indices.i32[5] = 13;
indices.i32[6] = 11;
indices.i32[7] = 9;

// Initialize the mask value
mask.i32[0] = merge_yes;
mask.i32[1] = merge_yes;
mask.i32[2] = merge_no;
mask.i32[3] = merge_yes;
mask.i32[4] = merge_yes;
mask.i32[5] = merge_no;
mask.i32[6] = merge_yes;
mask.i32[7] = merge_yes;

printf("\nResults for AvxGatherFloat()\n");
printf("Test array\n");
for (int i = 0; i < n; i++)
    printf("x[%02d]: %6.1f\n", i, x[i]);
printf("\n");

const char* s1 = "Values BEFORE call to AvxGatherFloat_()";
const char* s2 = "Values AFTER call to AvxGatherFloat_()";

AvxGatherFloatPrint(s1, des, indices, mask);
AvxGatherFloat_(&des, &indices, &mask, x);
AvxGatherFloatPrint(s2, des, indices, mask);
}

void AvxGatherI64(void)
{
    const Int64 merge_no = 0;
    const Int64 merge_yes = 0x8000000000000000LL;
    const int n = 15;

```

```

    Int64 x[n];
    __declspec(align(32)) YmmVal des;
    __declspec(align(16)) XmmVal indices;
    __declspec(align(32)) YmmVal mask;

    // Initialize the test array
    srand(36);
    for (int i = 0; i < n; i++)
        x[i] = (Int64)(rand() % 1000);

    // Load des with initial values
    for (int i = 0; i < 4; i++)
        des.i64[i] = -1;

    // Initialize the indices and mask elements
    indices.i32[0] = 2;
    indices.i32[1] = 7;
    indices.i32[2] = 9;
    indices.i32[3] = 12;

    mask.i64[0] = merge_yes;
    mask.i64[1] = merge_yes;
    mask.i64[2] = merge_no;
    mask.i64[3] = merge_yes;

    printf("\nResults for AvxGatherI64()\n");
    printf("Test array\n");
    for (int i = 0; i < n; i++)
        printf("x[%02d]: %8lld\n", i, x[i]);
    printf("\n");

    const char* s1 = "Values BEFORE call to AvxGatherI64_()";
    const char* s2 = "Values AFTER call to AvxGatherI64_()";

    AvxGatherI64Print(s1, des, indices, mask);
    AvxGatherI64_(&des, &indices, &mask, x);
    AvxGatherI64Print(s2, des, indices, mask);
}

int _tmain(int argc, _TCHAR* argv[])
{
    AvxGatherFloat();
    AvxGatherI64();
    return 0;
}

```

Listing 16-10. AvxGather_.asm

```

        .model flat,c
        .code

; extern "C" void AvxGatherFloat_(YmmVal* des, YmmVal* indices, YmmVal* mask, ←
mask, const float* x);
;
; Description: The following function demonstrates use of the
;               vgatherdps instruction.
;
; Requires:     AVX2

AvxGatherFloat_proc
    push ebp
    mov ebp,esp
    push ebx

; Load argument values. The contents of des are loaded into ymm0
; prior to execution of the vgatherdps instruction in order to
; demonstrate the conditional effects of the control mask.
    mov eax,[ebp+8]           ;eax = ptr to des
    mov ebx,[ebp+12]         ;ebx = ptr to indices
    mov ecx,[ebp+16]         ;ecx = ptr to mask
    mov edx,[ebp+20]         ;edx = ptr to x
    vmovaps ymm0,ymmword ptr [eax] ;ymm0 = des (initial values)
    vmovdq ymm1,ymmword ptr [ebx] ;ymm1 = indices
    vmovdq ymm2,ymmword ptr [ecx] ;ymm2 = mask

; Perform the gather operation and save the results.
    vgatherdps ymm0,[edx+ymm1*4],ymm2 ;ymm0 = gathered elements
    vmovaps ymmword ptr [eax],ymm0   ;save des
    vmovdq ymmword ptr [ebx],ymm1    ;save indices (unchanged)
    vmovdq ymmword ptr [ecx],ymm2    ;save mask (all zeros)

    vzeroupper
    pop ebx
    pop ebp
    ret
AvxGatherFloat_endp

; extern "C" void AvxGatherI64_(YmmVal* des, XmmVal* indices, YmmVal* mask, ←
const Int64* x);
;
; Description: The following function demonstrates use of the vpgatherdq
;               instruction.
;
; Requires:     AVX2

```

```

AvxGatherI64_ proc
    push ebp
    mov ebp,esp
    push ebx

; Load argument values. Note that the indices are loaded.
; into register XMM1.
    mov eax,[ebp+8]           ;eax = ptr to des
    mov ebx,[ebp+12]        ;ebx = ptr to indices
    mov ecx,[ebp+16]        ;ecx = ptr to mask
    mov edx,[ebp+20]        ;edx = ptr to x
    vmovdqa ymm0,ymmword ptr [eax] ;ymm0 = des (initial values)
    vmovdqa xmm1,xmmword ptr [ebx] ;xmm1 = indices
    vmovdqa ymm2,ymmword ptr [ecx] ;ymm2 = mask

; Perform the gather and save the results. Note that the
; scale factor matches the size of the gathered elements.
    vpgatherdq ymm0,[edx+xmm1*8],ymm2 ;ymm0 = gathered elements
    vmovdqa ymmword ptr [eax],ymm0 ;save des
    vmovdqa xmmword ptr [ebx],xmm1 ;save indices (unchanged)
    vmovdqa ymmword ptr [ecx],ymm2 ;save mask (all zeros)

    vzeroupper
    pop ebx
    pop ebp
    ret
AvxGatherI64_ endp
end

```

Chapter 12 presented an overview of the x86-AVX gather instructions, including a graphic (see Figure 12-4) that illustrated execution of a gather instruction. You may find it helpful to review that material prior to perusing the comments and sample code in this section.

The C++ file `AvxGather.cpp` (see Listing 16-9) includes a function named `AvxGatherFloat`, which initializes a test case in order to demonstrate use of the `vgatherdps` (Gather Packed SPFP Values Using Signed Dword Indices) instruction. This function starts by initializing an array of single-precision floating-point values that will be used by the `vgatherdps` instruction as its source array. It then loads the necessary array indices into the `YmmVal` instance `indices`. Note that the values in `indices` are treated as signed integers. The `YmmVal` variable `mask` is initialized next, which selects the values that are ultimately copied from the source array to `des`. The `AvxGather.cpp` file also includes a function named `AvxGatherI64`. This function prepares a test array, a set of indices, and a control mask in order to illustrate use of the `vpgatherdq` (Gather Packed Qword Values Using Signed Dword Indices) instruction.

Listing 16-10 shows the assembly language code for sample program `AvxGather`. The `AvxGatherFloat` _function loads `des`, `indices`, and `mask` into registers `YMM0`, `YMM1`, and `YMM2`, respectively. It also load a pointer to the source array `x` into register `EDX`.

The `vgatherdps ymm0,[edx+ymm1*4],ymm2` instruction performs the actual gather operation. Note that the VSIB operand uses a scale factor of four, which designates that the size of each element in the source array is four bytes. The scale factor also specifies the size of the elements in the control mask. The use of an incorrect scale factor by a gather instruction will yield an invalid result. Following execution of the `vgatherdps` instruction, registers `YMM0`, `YMM1`, and `YMM2` are saved to `des`, `indices`, and `mask`. The organization of assembly language function `AvxGatherI64_` is similar to `AvxGatherFloat_`. One noteworthy difference between these two functions is the former's use of `XMM1` to hold the indices. The `vpgatherdq ymm0,[edx+xmm1*8],ymm2` instruction uses a scale factor of eight since the instruction is gathering quadword values from the source array.

Output 16-4 shows the results for sample program `AvxGather`. The x86-AVX gather instructions are somewhat atypical in that they modify the source operand register that contains the control mask. This is illustrated in the output. The control mask register of a gather instruction is set to all zeros if the instruction completes its execution without causing a processor exception.

Output 16-4. Sample Program `AvxGather`

Results for `AvxGatherFloat()`

Test array

```
x[00]: 110.0
x[01]: 808.0
x[02]: 34.0
x[03]: 542.0
x[04]: 399.0
x[05]: 649.0
x[06]: 303.0
x[07]: 653.0
x[08]: 257.0
x[09]: 427.0
x[10]: 599.0
x[11]: 70.0
x[12]: 446.0
x[13]: 852.0
x[14]: 245.0
```

Values BEFORE call to `AvxGatherFloat_()`

```
ElementID: 0 des: -1.0 indices: 2 mask: 0x80000000
ElementID: 1 des: -1.0 indices: 1 mask: 0x80000000
ElementID: 2 des: -1.0 indices: 6 mask: 0x00000000
ElementID: 3 des: -1.0 indices: 5 mask: 0x80000000
ElementID: 4 des: -1.0 indices: 4 mask: 0x80000000
ElementID: 5 des: -1.0 indices: 13 mask: 0x00000000
ElementID: 6 des: -1.0 indices: 11 mask: 0x80000000
ElementID: 7 des: -1.0 indices: 9 mask: 0x80000000
```

Values AFTER call to AvxGatherFloat_()

```
ElementID: 0 des:      34.0 indices:   2 mask: 0x00000000
ElementID: 1 des:     808.0 indices:   1 mask: 0x00000000
ElementID: 2 des:     -1.0 indices:   6 mask: 0x00000000
ElementID: 3 des:     649.0 indices:   5 mask: 0x00000000
ElementID: 4 des:     399.0 indices:   4 mask: 0x00000000
ElementID: 5 des:     -1.0 indices:  13 mask: 0x00000000
ElementID: 6 des:      70.0 indices:  11 mask: 0x00000000
ElementID: 7 des:     427.0 indices:   9 mask: 0x00000000
```

Results for AvxGatherI64()

Test array

```
x[00]:    156
x[01]:    446
x[02]:    988
x[03]:    748
x[04]:    731
x[05]:     87
x[06]:    109
x[07]:    207
x[08]:     43
x[09]:    890
x[10]:    528
x[11]:    686
x[12]:    710
x[13]:    125
x[14]:    255
```

Values BEFORE call to AvxGatherI64_()

```
ElementID: 0 des:     -1 indices:   2 mask: 0x8000000000000000
ElementID: 1 des:     -1 indices:   7 mask: 0x8000000000000000
ElementID: 2 des:     -1 indices:   9 mask: 0x0000000000000000
ElementID: 3 des:     -1 indices:  12 mask: 0x8000000000000000
```

Values AFTER call to AvxGatherI64_()

```
ElementID: 0 des:    988 indices:   2 mask: 0x0000000000000000
ElementID: 1 des:    207 indices:   7 mask: 0x0000000000000000
ElementID: 2 des:     -1 indices:   9 mask: 0x0000000000000000
ElementID: 3 des:    710 indices:  12 mask: 0x0000000000000000
```

Fused-Multiply-Add Programming

Fused-multiply-add operations are suitable for use in a wide variety of algorithmic domains, including computer graphics and signal processing. The sample program of this section, called `AvxFma`, demonstrates how to implement a common signal-processing technique using FMA instructions. Listings 16-11 and 16-12 contain the C++ and assembly language source code for sample program `AvxFma`.

Listing 16-11. AvxFma.cpp

```

#include "stdafx.h"
#include "AvxFma.h"
#include <stdio.h>
#include <malloc.h>
#define _USE_MATH_DEFINES
#include <math.h>
#include <stdlib.h>

bool AvxFmaInitX(float* x, Uint32 n)
{
    const float degtorad = (float)(M_PI / 180.0);
    const float t_start = 0;
    const float t_step = 0.002f;
    const Uint32 m = 3;
    const float amp[m] = {1.0f, 0.80f, 1.20f};
    const float freq[m] = {5.0f, 10.0f, 15.0f};
    const float phase[m] = {0.0f, 45.0f, 90.0f};
    float t = t_start;

    srand(97);

    for (Uint32 i = 0; i < n; i++, t += t_step)
    {
        float x_total = 0;

        for (Uint32 j = 0; j < m; j++)
        {
            float omega = 2.0f * (float)M_PI * freq[j];
            float x_temp1 = amp[j] * sin(omega * t + phase[j] * degtorad);
            float noise = (float)((rand() % 300) - 150) / 10.0f;
            float x_temp2 = x_temp1 + x_temp1 * noise / 100.0f;

            x_total += x_temp2;
        }

        x[i] = x_total;
    }

    return true;
}

```

```

void AvxFmaSmooth5Cpp(float* y, const float*x, Uint32 n, const float*
sm5_mask)
{
    for (Uint32 i = 2; i < n - 2; i++)
    {
        float sum = 0;

        sum += x[i - 2] * sm5_mask[0];
        sum += x[i - 1] * sm5_mask[1];
        sum += x[i + 0] * sm5_mask[2];
        sum += x[i + 1] * sm5_mask[3];
        sum += x[i + 2] * sm5_mask[4];
        y[i] = sum;
    }
}

void AvxFma(void)
{
    const Uint32 n = 512;
    float* x = (float*)_aligned_malloc(n * sizeof(float), 32);
    float* y_cpp = (float*)_aligned_malloc(n * sizeof(float), 32);
    float* y_a = (float*)_aligned_malloc(n * sizeof(float), 32);
    float* y_b = (float*)_aligned_malloc(n * sizeof(float), 32);
    float* y_c = (float*)_aligned_malloc(n * sizeof(float), 32);
    const float sm5_mask[] = { 0.0625f, 0.25f, 0.375f, 0.25f, 0.0625f };

    printf("Results for AvxFma\n");

    if (!AvxFmaInitX(x, n))
    {
        printf("Data initialization failed\n");
        return;
    }

    AvxFmaSmooth5Cpp(y_cpp, x, n, sm5_mask);
    AvxFmaSmooth5a_(y_a, x, n, sm5_mask);
    AvxFmaSmooth5b_(y_b, x, n, sm5_mask);
    AvxFmaSmooth5b_(y_c, x, n, sm5_mask);

    FILE* fp;
    const char* fn = "__AvxFmaRawData.csv";

    if (fopen_s(&fp, fn, "wt") != 0)
    {
        printf("File open failed (%s)\n", fn);
        return;
    }
}

```

```

fprintf(fp, "i, x, y_cpp, y_a, y_b, y_c, ");
fprintf(fp, "diff_ab, diff_ac, diff_bc\n");

Uint32 num_diff_ab = 0, num_diff_ac = 0, num_diff_bc = 0;

for (Uint32 i = 2; i < n - 2; i++)
{
    bool diff_ab = false, diff_ac = false, diff_bc = false;

    if (y_a[i] != y_b[i])
    {
        diff_ab = true;
        num_diff_ab++;
    }

    if (y_a[i] != y_c[i])
    {
        diff_ac = true;
        num_diff_ac++;
    }

    if (y_b[i] != y_c[i])
    {
        diff_bc = true;
        num_diff_bc++;
    }

    const char* fs1 = "%15.8f, ";
    fprintf(fp, "%4d, ", i);
    fprintf(fp, fs1, x[i]);
    fprintf(fp, fs1, y_cpp[i]);
    fprintf(fp, fs1, y_a[i]);
    fprintf(fp, fs1, y_b[i]);
    fprintf(fp, fs1, y_c[i]);
    fprintf(fp, "%d, %d, %d, ", diff_ab, diff_ac, diff_bc);
    fprintf(fp, "\n");
}

fclose(fp);
printf("\nRaw data saved to file %s\n", fn);
printf("\nNumber of data point differences between\n");
printf("  y_a and y_b: %u\n", num_diff_ab);
printf("  y_a and y_c: %u\n", num_diff_ac);
printf("  y_b and y_c: %u\n", num_diff_bc);

```

```

    _aligned_free(x);
    _aligned_free(y_cpp);
    _aligned_free(y_a);
    _aligned_free(y_b);
    _aligned_free(y_c);
}

int _tmain(int argc, _TCHAR* argv[])
{
    try
    {
        AvxFma();
        AvxFmaTimed();
    }

    catch (...)
    {
        printf("Unexpected exception has occurred!\n");
        printf("File: %s (_tmain)\n", __FILE__);
    }

    return 0;
}

```

Listing 16-12. AvxFma.asm

```

.model flat,c
.code

; void AvxFmaSmooth5a_(float* y, const float*x, Uint32 n, const float*
sm5_mask);
;
; Description: The following function applies a weighted-average
;               smoothing transformation to the input array x using
;               scalar SPFP multiplication and addition.
;
; Requires:     AVX

AvxFmaSmooth5a_proc
    push ebp
    mov ebp,esp
    push esi
    push edi

; Load argument values
    mov edi,[ebp+8]           ;edi = ptr to y
    mov esi,[ebp+12]        ;esi = ptr to x
    mov ecx,[ebp+16]        ;ecx = n
    mov eax,[ebp+20]        ;eax = ptr to sm5_mask

```



```

    add esi,8                ;adjust pointers and
    add edi,8                ;counter to skip first 2
    sub ecx,4                ;and last 2 elements
    align 16

; Apply smoothing operator to each element of x
@@:   vxorps xmm6,xmm6,xmm6    ;x_total=0

; Compute x_total += x[i-2]*sm5_mask[0]
    vmovss xmm0,real4 ptr [esi-8]
    vmulss xmm1,xmm0,real4 ptr [eax]
    vaddss xmm6,xmm6,xmm1

; Compute x_total += x[i-1]*sm5_mask[1]
    vmovss xmm2,real4 ptr [esi-4]
    vmulss xmm3,xmm2,real4 ptr [eax+4]
    vaddss xmm6,xmm6,xmm3

; Compute x_total += x[i]*sm5_mask[2]
    vmovss xmm0,real4 ptr [esi]
    vmulss xmm1,xmm0,real4 ptr [eax+8]
    vaddss xmm6,xmm6,xmm1

; Compute x_total += x[i+1]*sm5_mask[3]
    vmovss xmm2,real4 ptr [esi+4]
    vmulss xmm3,xmm2,real4 ptr [eax+12]
    vaddss xmm6,xmm6,xmm3

; Compute x_total += x[i+2]*sm5_mask[4]
    vmovss xmm0,real4 ptr [esi+8]
    vmulss xmm1,xmm0,real4 ptr [eax+16]
    vaddss xmm6,xmm6,xmm1

; Save x_total
    vmovss real4 ptr [edi],xmm6

    add esi,4
    add edi,4
    sub ecx,1
    jnz @B

    pop edi
    pop esi
    pop ebp
    ret
AvxFmaSmooth5a_ endp

```

```
; void AvxFmaSmooth5b_(float* y, const float*x, Uint32 n, const float*
sm5_mask);
```

```
;
; Description: The following function applies a weighted-average
; smoothing transformation to the input array x using
; scalar SPFP fused-multiply-add operations.
;
; Requires: AVX2, FMA
```

```
AvxFmaSmooth5b_proc
```

```
    push ebp
    mov  ebp,esp
    push esi
    push edi
```

```
; Load argument values
```

```
    mov  edi,[ebp+8]           ;edi = ptr to y
    mov  esi,[ebp+12]        ;esi = ptr to x
    mov  ecx,[ebp+16]        ;ecx = n
    mov  eax,[ebp+20]        ;eax = ptr to sm5_mask
```

```
    add  esi,8                ;adjust pointers and
    add  edi,8                ;counter to skip first 2
    sub  ecx,4                ;and last 2 elements
    align 16
```

```
; Apply smoothing operator to each element of x
```

```
@@:  vxorps xmm6,xmm6,xmm6    ;set x_total1 = 0
      vxorps xmm7,xmm7,xmm7    ;set x_total2 = 0
```

```
; Compute x_total1 = x[i-2] * sm5_mask[0] + x_total1
```

```
    vmovss xmm0,real4 ptr [esi-8]
    vfmadd231ss xmm6,xmm0,real4 ptr [eax]
```

```
; Compute x_total2 = x[i-1] * sm5_mask[1] + x_total2
```

```
    vmovss xmm2,real4 ptr [esi-4]
    vfmadd231ss xmm7,xmm2,real4 ptr [eax+4]
```

```
; Compute x_total1 = x[i] * sm5_mask[2] + x_total1
```

```
    vmovss xmm0,real4 ptr [esi]
    vfmadd231ss xmm6,xmm0,real4 ptr [eax+8]
```

```
; Compute x_total2 = x[i+1] * sm5_mask[3] + x_total2
```

```
    vmovss xmm2,real4 ptr [esi+4]
    vfmadd231ss xmm7,xmm2,real4 ptr [eax+12]
```

```

; Compute x_total1 = x[i+2] * sm5_mask[4] + x_total1
    vmovss xmm0,real4 ptr [esi+8]
    vfmadd231ss xmm6,xmm0,real4 ptr [eax+16]

```

```

; Compute final x_total and save result
    vaddss xmm5,xmm6,xmm7
    vmovss real4 ptr [edi],xmm5

```

```

    add esi,4
    add edi,4
    sub ecx,1
    jnz @B

```

```

    pop edi
    pop esi
    pop ebp
    ret

```

AvxFmaSmooth5b_ endp

```

; void AvxFmaSmooth5c_(float* y, const float*x, Uint32 n, const float*
sm5_mask);

```

```

; Description: The following function applies a weighted-average
;              smoothing transformation to the input array x using
;              scalar SPFP fused-multiply-add operations.
;
; Requires:    AVX2, FMA

```

```

AvxFmaSmooth5c_ proc
    push ebp
    mov  ebp,esp
    push esi
    push edi

```

```

; Load argument values
    mov  edi,[ebp+8]           ;edi = ptr to y
    mov  esi,[ebp+12]        ;esi = ptr to x
    mov  ecx,[ebp+16]        ;ecx = n
    mov  eax,[ebp+20]        ;eax = ptr to sm5_mask

    add  esi,8                ;adjust pointers and
    add  edi,8                ;counter to skip first 2
    sub  ecx,4                ;and last 2 elements
    align 16

```

```

; Apply smoothing operator to each element of x, save result to y
@@:   vxorps xmm6,xmm6,xmm6           ;set x_total = 0

; Compute x_total = x[i-2] * sm5_mask[0] + x_total
      vmovss xmm0,real4 ptr [esi-8]
      vfmadd231ss xmm6,xmm0,real4 ptr [eax]

; Compute x_total = x[i-1] * sm5_mask[1] + x_total
      vmovss xmm0,real4 ptr [esi-4]
      vfmadd231ss xmm6,xmm0,real4 ptr [eax+4]

; Compute x_total = x[i] * sm5_mask[2] + x_total
      vmovss xmm0,real4 ptr [esi]
      vfmadd231ss xmm6,xmm0,real4 ptr [eax+8]

; Compute x_total = x[i+1] * sm5_mask[3] + x_total
      vmovss xmm0,real4 ptr [esi+4]
      vfmadd231ss xmm6,xmm0,real4 ptr [eax+12]

; Compute x_total = x[i+2] * sm5_mask[4] + x_total
      vmovss xmm0,real4 ptr [esi+8]
      vfmadd231ss xmm6,xmm0,real4 ptr [eax+16]

; Save result
      vmovss real4 ptr [edi],xmm6

      add esi,4
      add edi,4
      sub ecx,1
      jnz @B

      pop edi
      pop esi
      pop ebp
      ret
AvxFmaSmooth5c_ endp
end

```

Smoothing transformations are often used to reduce the amount of noise that's present in a signal, as shown in Figure 16-2. In this figure, the raw signal in the top graph contains a fair amount of noise. The signal in the bottom graph presents the data subsequent to the application of a smoothing operator. A smoothing operator is a set of constant weight values that are applied to each raw signal data point and its adjacent neighbors. Figure 16-3 illustrates this technique in greater detail. The application of a smoothing operator to each raw signal data point normally involves successive multiplications and additions. This means that data-smoothing algorithms are ideal for implementation using FMA operations.

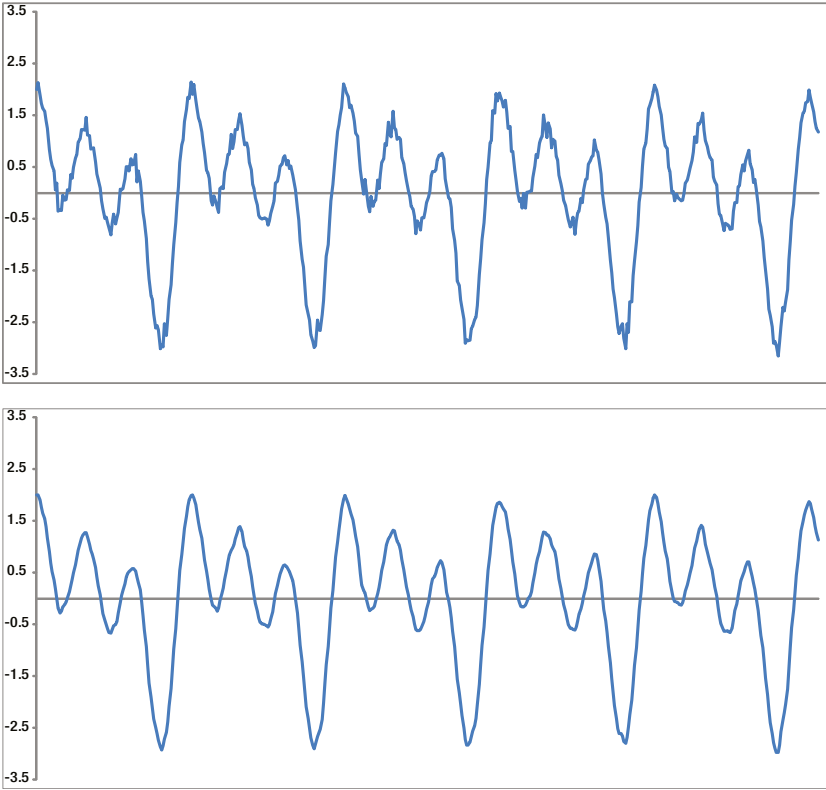

Figure 16-2. Illustration of a raw data signal (top) and its smoothed counterpart (bottom)

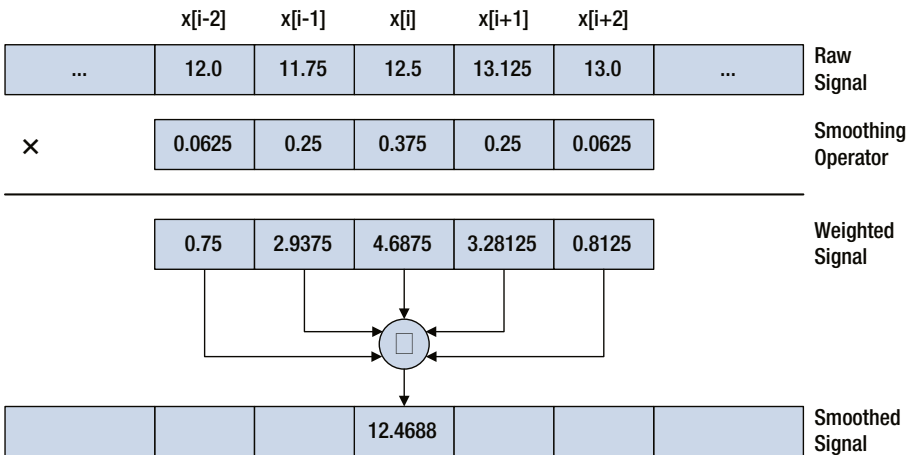

Figure 16-3. Application of a smoothing operator to a raw signal data point

The C++ file `AvxFma.cpp` (see Listing 16-11) contains a function named `AvxFmaInitX`. This function constructs a synthetic raw data signal and saves the corresponding data points to an array for test purposes. The raw data signal consists of three sinusoidal waveforms that are summed along with some random noise. The raw data signal corresponds to the top graph in Figure 16-2. Following `AvxFmaInitX` is a function named `AvxFmaSmooth5Cpp`, which applies the smoothing operator to the raw data signal `x`. Note that the smoothing operator is not applied to the first two and last two data points in `x` in order to simplify both the C++ and assembly language versions of the algorithm.

The other function of note in `AvxFma.cpp` is called `AvxFma`. This function allocates space for the required signal arrays, invokes the various smoothing functions, and saves the results. Besides the function `AvxFmaSmooth5Cpp`, `AvxFma` also calls the smoothing functions `AvxFmaSmooth5a_`, `AvxFmaSmooth5b_`, and `AvxFmaSmooth5c_`. These functions implement the smoothing algorithm using different assembly language instruction sequences.

Listing 16-12 shows the source code for the aforementioned assembly language smoothing functions. The `AvxFmaSmooth5a_` function carries out the smoothing technique using a series of `vmulss` and `vaddss` instructions. Note that when performing multiplication, the `AvxFmaSmooth5a_` function alternates between XMM register pairs, which improves performance. The `AvxFmaSmooth5b_` function takes advantage of the `vmadd231ss` (Fused Multiply-Add of Scalar Single-Precision Floating-Point Values) instruction to perform data smoothing. This function employs multiple XMM registers to compute two intermediate FMA results. These intermediate values are then summed using a `vaddss` instruction, which generates the final result.

Effective use of the FMA instructions often requires a bit of programming diligence in order to avoid inadvertent performance delays. For example, the `AvxFmaSmooth5c_` function also employs the `vmadd231ss` instruction, but each instruction uses XMM6 as its destination register. This creates a detrimental data dependency that prevents the processor from fully exploiting all of its FMA execution units (processor execution units are discussed in Chapter 21).

Table 16-2 contains timing measurements for the various smoothing functions in sample program `AvxFma`. Note that the mean execution time of the `Smooth5b_` function, which uses FMA instructions, is about 5% faster than the non-FMA function `Smooth5a_`. In other words, performing five FMA operations is noticeably faster than five discrete multiplications and additions. Also note that the intentional data dependency added to `Smooth5c_` causes it to execute about 7% slower than `Smooth5b_`, even though both functions use the `vmadd231ss` instruction. The `Smooth5c_` function is also slower than the non-FMA function `Smooth5a_`. The lesson of sample program `AvxFma` is that simple replacement of discrete multiplications and additions with an equivalent FMA instruction is not guaranteed to improve performance, and may actually be slower if the code contains critical data dependencies.

Table 16-2. Mean Execution Times (in Microseconds) of the Smoothing Functions (50,000 Data Points)

CPU	C++	Smooth5a_ vmulss,vaddss	Smooth5b_ vfmadd231ss	Smooth5c_ vfmadd231ss (One XMM reg.)
Intel Core i7-4770	76.4	73.7	70.2	75.1
Intel Core i7-4600U	116.7	109.1	104.5	112.4

Not surprisingly, a function that performs its calculations using FMA operations normally generates slightly different results than an equivalent function using discrete multiplication and addition. This is confirmed by the results of sample program `AvxFma` (see Output 16-5), which shows the number of data point differences between the various result arrays. The output file `__AvxFmaRawData.csv` contains the raw data points along with the smoothed values computed by each implementation of the algorithm. Table 16-3 contains a few examples of data points from this file that are different. For this sample program, the magnitudes of these differences are insignificant given that the smoothing algorithm performs only five multiply-add operations per data point. The benefits of FMA's improved precision are likely to be more apparent in algorithms that require numerous multiply-add operations or in programs where the accumulation of rounding errors must be kept to a minimum.

Output 16-5. Sample Program `AvxFma`

Results for `AvxFma`

Raw data saved to file `__AvxFmaRawData.csv`

Number of data point differences between

`y_a` and `y_b`: 178

`y_a` and `y_c`: 178

`y_b` and `y_c`: 0

Benchmark times saved to file `__AvxFmaTimed.csv`

Table 16-3. Examples of Data Point Values Using Various Smoothing Algorithms

Index	x	C++	Smooth5a_	Smooth5b_	Smooth5c_
4	1.89155102	1.90318263	1.90318263	1.90318251	1.90318251
17	-0.323192	-0.28281462	-0.28281462	-0.28281465	-0.28281465
120	-0.37265474	-0.19113629	-0.19113629	-0.19113627	-0.19113627
135	1.30851579	1.29426527	1.29426527	1.29426503	1.29426503
482	-2.9402566	-2.96991372	-2.96991372	-2.96991324	-2.96991324

General-Purpose Register Instructions

Processors based on recent micro architectures such as Has well include several new general-purpose register instructions. These instructions can be used to carry out flagless multiplication and shift operations, which are faster than their flag-based counterparts. Instructions are also available that support enhanced bit-manipulation operations. The sample code in this section illustrates how to perform flagless multiplications and shifts. It also demonstrates use of several enhanced bit-manipulation instructions.

Flagless Multiplication and Bit Shifts

In this section, you examine a sample program named `AvxGprMulxShiftx`, which illustrates use of the flagless unsigned integer multiplication and shift instructions. Listings 16-13 and 16-14 show the C++ and assembly language source code for sample program `AvxGprMulxShiftx`.

Listing 16-13. `AvxGprMulxShiftx.cpp`

```
#include "stdafx.h"
#include "MiscDefs.h"

extern "C" UInt64 AvxGprMulx_(UInt32 a, UInt32 b, UInt8 flags[2]);
extern "C" void AvxGprShiftx_(Int32 x, UInt32 count, Int32 results[3]);

void AvxGprMulx(void)
{
    const int n = 3;
    UInt32 a[n] = {64, 3200, 100000000};
    UInt32 b[n] = {1001, 12, 250000000};

    printf("Results for AvxGprMulx()\n");
    for (int i = 0; i < n; i++)
    {
        UInt8 flags[2];
        UInt64 c = AvxGprMulx_(a[i], b[i], flags);

        printf("Test case %d\n", i);
        printf(" a: %u b: %u c: %llu\n", a[i], b[i], c);
        printf(" status flags before mulx: 0x%02X\n", flags[0]);
        printf(" status flags after mulx: 0x%02X\n", flags[1]);
    }
}

void AvxGprShiftx(void)
{
    const int n = 4;
    Int32 x[n] = { 0x00000008, 0x80000080, 0x00000040, 0xfffffc10 };
    UInt32 count[n] = { 2, 5, 3, 4 };
}
```



```

printf("\nResults for AvxGprShiftx()\n");
for (int i = 0; i < n; i++)
{
    Int32 results[3];

    AvxGprShiftx_(x[i], count[i], results);
    printf("Test case %d\n", i);
    printf(" x:   0x%08X (%11d) count: %u\n", x[i], x[i], count[i]);
    printf(" sarx: 0x%08X (%11d)\n", results[0], results[0]);
    printf(" shlx: 0x%08X (%11d)\n", results[1], results[1]);
    printf(" shrx: 0x%08X (%11d)\n", results[2], results[2]);
}
}

int _tmain(int argc, _TCHAR* argv[])
{
    AvxGprMulx();
    AvxGprShiftx();
    return 0;
}

```

Listing 16-14. AvxGprMulxShiftx_.asm

```

.model flat,c
.code

; extern "C" UInt64 AvxGprMulx_(UInt32 a, UInt32 b, UInt8 flags[2]);
;
; Description: The following function demonstrates use of the
;               flagless unsigned integer multiply instruction mulx.
;
; Requires     BMI2.

AvxGprMulx_ proc
    push ebp
    mov ebp,esp

; Save copy of status flags before mulx
    mov ecx,[ebp+16]
    lahf
    mov byte ptr [ecx],ah

; Perform flagless multiplication. The mulx instruction below computes
; the product of explicit source operand [ebp+8] and implicit source
; operand edx. The 64-bit result is saved to the register pair edx:eax.
    mov edx,[ebp+12]                ;edx = b
    mulx edx,eax,[ebp+8]            ;edx:eax = [ebp+8] * edx

```

```

; Save copy of status flags after mulx
    push eax
    lahf
    mov byte ptr [ecx+1],ah
    pop eax

    pop ebp
    ret
AvxGprMulx_ endp

; extern "C" void AvxGprShiftx_(Int32 x, Uint32 count, Int32 results[3]);
;
; Description: The following function demonstrates use of the flagless
;              shift instructions sarx, shlx, and shrx.
;
; Requires     BMI2

AvxGprShiftx_ proc
    push ebp
    mov ebp,esp

; Load argument values and perform shifts. Note that each shift
; instruction requires three operands: DesOp, SrcOp, and CountOp.
    mov ecx,[ebp+12]        ;ecx = shift bit count
    mov edx,[ebp+16]        ;edx = ptr to results

    sarx eax,[ebp+8],ecx    ;shift arithmetic right
    mov [edx],eax
    shlx eax,[ebp+8],ecx    ;shift logical left
    mov [edx+4],eax
    shrx eax,[ebp+8],ecx    ;shift logical right
    mov [edx+8],eax

    pop ebp
    ret
AvxGprShiftx_ endp
end

```

The `AvxGprMulxShiftx.cpp` file (see Listing 16-13) contains two functions named `AvxGprMulx` and `AvxGprShiftx`. These functions set up test cases that demonstrate flagless multiplication and shift operations, respectively. In function `AvxGprMulx`, the `flags` array contains the values of the status bits in `EFLAGS` before and after each flagless multiplication operation.

Listing 16-14 shows the assembly language code for sample program `AvxGprMulxShiftx`. The `AvxGprMulx_` function uses a `mulx edx, eax, [ebp+8]` (Unsigned Multiply Without Affecting Flags) instruction to perform flagless multiplication. This instruction multiplies the contents of memory location `[ebp+8]` by implicit operand `EDX`

and saves the 64-bit unsigned product to register pair EDX:EAX. Note that a `lahf` (Load Status Flags into AH register) instruction is used before and after `mulx` in order to verify that the status bits in EFLAGS were not modified.

The `AvxGprShift_` function includes examples of the `sarx`, `shlx`, and `shrx` (Shift Without Affecting Flags) instructions. These instructions shift the first source operand by the count value that's specified in the second source operand. The result is then saved to the destination operand. Output 16-6 shows the results for sample program `AvxGprMulxShiftx`.

Output 16-6. Sample Program `AvxGprMulxShiftx`

Results for `AvxGprMulx()`

Test case 0

```
a: 64 b: 1001 c: 64064
status flags before mulx: 0x46
status flags after mulx: 0x46
```

Test case 1

```
a: 3200 b: 12 c: 38400
status flags before mulx: 0x93
status flags after mulx: 0x93
```

Test case 2

```
a: 100000000 b: 250000000 c: 25000000000000000
status flags before mulx: 0x97
status flags after mulx: 0x97
```

Results for `AvxGprShiftx()`

Test case 0

```
x: 0x00000008 ( 8) count: 2
sarx: 0x00000002 ( 2)
shlx: 0x00000020 ( 32)
shrx: 0x00000002 ( 2)
```

Test case 1

```
x: 0x80000080 (-2147483520) count: 5
sarx: 0xFC000004 (-67108860)
shlx: 0x00001000 ( 4096)
shrx: 0x04000004 ( 67108868)
```

Test case 2

```
x: 0x00000040 ( 64) count: 3
sarx: 0x00000008 ( 8)
shlx: 0x00000200 ( 512)
shrx: 0x00000008 ( 8)
```

Test case 3

```
x: 0xFFFFFC10 (-1008) count: 4
sarx: 0xFFFFFC1 (-63)
shlx: 0xFFFFC100 (-16128)
shrx: 0x0FFFFFC1 ( 268435393)
```

Enhanced Bit Manipulation

The final sample program in this chapter, `AvxGprBitManip`, illustrates how to use some of the new bit-manipulation instructions. It also demonstrates an alternative method of accessing argument values on the stack. The source code for sample program `AvxGprBitManip` is shown in Listings 16-15 and 16-16.

Listing 16-15. `AvxGprBitManip.cpp`

```
#include "stdafx.h"
#include "MiscDefs.h"

extern "C" void AvxGprCountZeroBits_(UInt32 x, UInt32* lzcnt, UInt32* tzcnt);
extern "C" UInt32 AvxGprBextr_(UInt32 x, UInt8 start, UInt8 length);
extern "C" UInt32 AvxGprAndNot_(UInt32 x, UInt32 y);

void AvxGprCountZeroBits(void)
{
    const int n = 5;
    UInt32 x[n] = { 0x001000008, 0x00008000, 0x8000000, 0x00000001, 0 };

    printf("\nResults for AvxGprCountZeroBits()\n");
    for (int i = 0; i < n; i++)
    {
        UInt32 lzcnt, tzcnt;

        AvxGprCountZeroBits_(x[i], &lzcnt, &tzcnt);
        printf("x: 0x%08X ", x[i]);
        printf("lzcnt: %2u ", lzcnt);
        printf("tzcnt: %2u\n", tzcnt);
    }
}

void AvxGprExtractBitField(void)
{
    const int n = 3;
    UInt32 x[n] = { 0x12345678, 0x80808080, 0xfedcba98 };
    UInt8 start[n] = { 4, 7, 24 };
    UInt8 len[n] = { 16, 9, 8 };

    printf("\nResults for AvxGprExtractBitField()\n");
    for (int i = 0; i < n; i++)
    {
        UInt32 bextr = AvxGprBextr_(x[i], start[i], len[i]);

        printf("x: 0x%08X ", x[i]);
        printf("start: %2u ", start[i]);
    }
}
```

```

        printf("len: %2u ", len[i]);
        printf("bextr: 0x%08X\n", bextr);
    }
}

void AvxGprAndNot(void)
{
    const int n = 3;
    Uint32 x[n] = { 0xf000000f, 0xff00ff00, 0xaaaaaaaa };
    Uint32 y[n] = { 0x12345678, 0x12345678, 0xfffaa5500 };

    printf("\nResults for AvxGprAndNot()\n");
    for (int i = 0; i < n; i++)
    {
        Uint32 andn = AvxGprAndNot_(x[i], y[i]);
        printf("x: 0x%08X y: 0x%08X z: 0x%08X\n", x[i], y[i], andn);
    }
}

int _tmain(int argc, _TCHAR* argv[])
{
    AvxGprCountZeroBits();
    AvxGprExtractBitField();
    AvxGprAndNot();
    return 0;
}

```

Listing 16-16. AvxGrpBitManip_.asm

```

        .model flat,c
        .code

; extern "C" void AvxGprCountZeroBits_(Uint32 x, Uint32* lzcnt, Uint32* tzcnt);
;
; Description: The following function demonstrates use of the lzcnt and
;               tzcnt instructions.
;
; Requires:     BMI1, LZCNT

AvxGprCountZeroBits_ proc
    mov eax,[esp+4]                ;eax = x

    lzcnt ecx,eax                 ;count leading zeros
    mov edx,[esp+8]
    mov [edx],ecx                 ;save result

```

```

        tzcnt ecx,eax                ;count trailing zeros
        mov  edx,[esp+8]
        mov  [edx],ecx              ;save result
        ret
AvxGprCountZeroBits_ endp

; extern "C" Uint32 AvxGprBextr_(Uint32 x, Uint8 start, Uint8 length);
;
; Description: The following function demonstrates use of the
;              bextr instruction.
;
; Requires:    BMI1

AvxGprBextr_ proc
        mov  cl,[esp+8]             ;cl = start index
        mov  ch,[esp+12]           ;ch = length of bit field
        bextr eax,[esp+4],ecx      ;eax = extracted bit field
        ret
AvxGprBextr_ endp

; extern "C" Uint32 AvxGprAndNot_(Uint32 x, Uint32 y);
;
; Description: The following function demonstrates use of the
;              andn instruction.
;
; Requires:    BMI1

AvxGprAndNot_ proc
        mov  ecx,[esp+4]
        andn eax,ecx,[esp+8]      ;eax = ~ecx & [esp+8]
        ret
AvxGprAndNot_ endp
end

```

Most of the new bit-manipulation instructions are geared toward improving the performance of specialized algorithms such as data encryption and decryption. They also can be employed to simplify bit-manipulation operations in more mundane algorithms. The sample program `AvxGprBitManip` demonstrates how to use some of the bit-manipulation instructions that have broad generic applications.

The C++ file `AvxGprBitManip.cpp` (see Listing 16-15) contains three short functions that set up test cases for the assembly language functions. The first function, named `AvxGprCountZeroBits`, initializes an array of test values for use with the `lzcnt` (Count the Number of Leading Zero Bits) and `tzcnt` (Count the Number of Trailing Zero Bits) instructions. The second function, called `AvxGprExtractBitField`, demonstrates the `bextr` (Bit Field Extract) instruction. The final function in `AvxGprBitManip` is called `AvxGprAndNot` and it prepares several test values for use with the `andn` (Logical AND NOT) instruction.

The assembly language functions that exercise the aforementioned bit-manipulation instructions are located in the `AvxGprBitManip.asm` file (see Listing 16-16). The `AvxGprCountZeroBits_` function demonstrates use of the `lzcnt` and `tzcnt` instructions, which count the number of leading and trailing zero bits, respectively, in the source operand. It also illustrates an alternative method of accessing argument values on the stack using the ESP register instead of EBP. Figure 16-4 shows the contents of the stack prior to execution of the `mov eax, [esp+4]` instruction, which uses the ESP register as a base pointer to access the argument `x` on the stack. This approach is suitable for short leaf functions (i.e., functions that do not call other functions). Note that register EBP is still considered a volatile register and its contents must be preserved. The drawback of using ESP instead of EBP is that the argument value offsets are not fixed; changing the value of ESP changes the offsets of any argument values (and local variables) on the stack.

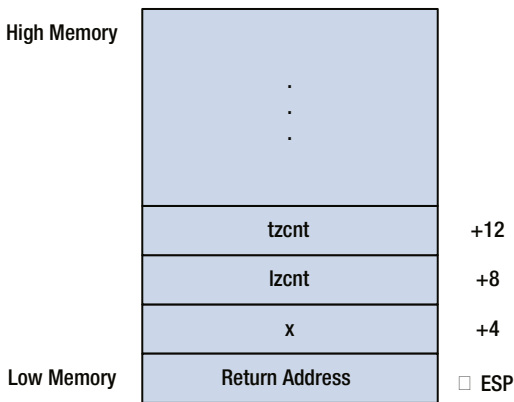

Figure 16-4. Stack contents at entry to function `AvxGprCountZeroBits_`

The `AvxGprBextr_` function exercises the `bextr` instruction. This instruction extracts a contiguous bit field from the first source operand using the start index and length specified by the second source operand. Note that the `AvxGprBextr_` function uses the instructions `mov cl, [esp+8]` and `mov ch, [esp+12]` to transfer the start index and length into the correct positions of the second source operand. The last assembly language function is named `AvxGprAndNot_`. This function shows how to use the `andn` instruction, which computes `DesOp = ~SrcOp1 & SrcOp2`. The `andn` instruction is often used to simplify Boolean masking operations. Output 16-7 presents the results for sample program `AvxGprBitManip`.

Output 16-7. Sample Program `AvxGprBitManip`

```
Results for AvxGprCountZeroBits()
x: 0x01000008  lzcnt: 7  tzcnt: 3
x: 0x00008000  lzcnt: 16  tzcnt: 15
x: 0x08000000  lzcnt: 4  tzcnt: 27
x: 0x00000001  lzcnt: 31  tzcnt: 0
x: 0x00000000  lzcnt: 32  tzcnt: 32
```

Results for AvxGprExtractBitField()

```
x: 0x12345678 start: 4 len: 16 bextr: 0x00004567
x: 0x80808080 start: 7 len: 9 bextr: 0x00000101
x: 0xFEDCBA98 start: 24 len: 8 bextr: 0x000000FE
```

Results for AvxGprAndNot()

```
x: 0xF000000F y: 0x12345678 z: 0x02345670
x: 0xFF00FF00 y: 0x12345678 z: 0x00340078
x: 0xAAAAAAAA y: 0xFFAA5500 z: 0x55005500
```

Summary

In this chapter, you learned how to use the `cpuid` instruction to detect processor support for x86-SSE, x86-AVX, and other x86 instruction set extensions. You also discovered how to exploit some of x86-AVX's data-manipulation instructions. Finally, you examined sample code that highlighted use of several new general-purpose instructions, including flagless operations and enhanced bit manipulations.

Thus far, this book's instructive material and sample code book has focused exclusively on x86-32 assembly language programming. This changes in the next chapter, where the focus shifts to learning about the x86's 64-bit computational resources and programming environment.



X86-64 Core Architecture

Chapter 17 explores the fundamentals of the x86-64 core architecture. It begins with an overview of its internal architecture, which includes details of the execution units, general-purpose registers, instruction operands, and memory addressing modes. Next is a discussion of the differences between the x86-64 and x86-32 execution environments that programmers need to be aware of when coding assembly language functions. The final section of this chapter encapsulates the x86-64 instruction set. All of the material in this chapter assumes that you have a basic understanding of the x86-32 core architecture and the x86-32 instruction set.

Internal Architecture

From the perspective of an application program, the internal architecture of an x86-64 processor can be logically partitioned into several distinct execution units, as shown in Figure 17-1. The core execution unit includes the general-purpose registers, RFLAGS register, and the RIP (or instruction pointer) register. Other execution units include the x87 FPU and the computational elements that perform SIMD operations. An executing task always uses the resources of the core execution unit; use of the x87 FPU or a SIMD resource is optional.

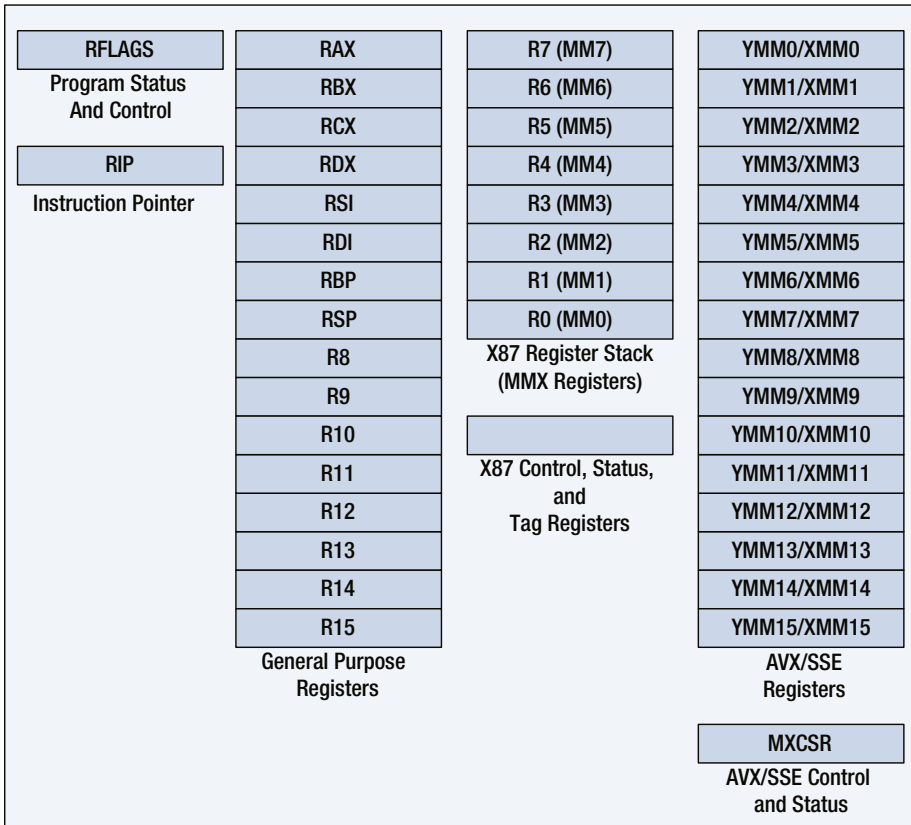

Figure 17-1. X86-64 internal architecture

The remainder of this section explores the x86-64 core execution unit in greater detail. It focuses on the execution elements that an application program uses, including the general-purpose registers, RFLAGS register, and the instruction pointer. Following this is an examination of x86-64 instruction operands and memory addressing modes. Use of the x87 FPU and MMX execution units by an x86-64 assembly language function is also mentioned later in this chapter. Chapter 19 discusses the x86-64 SIMD execution units.

General-Purpose Registers

The x86-64 core execution unit contains 16 64-bit general-purpose registers, which are used to perform arithmetic, logical, and address calculations. They also can be employed as pointers to reference data items in memory. The low-order doubleword, word, and byte of each 64-bit register are independently accessible and can be used to manipulate 32-bit, 16-bit, and 8-bit wide operands. Figure 17-2 shows the complete set of general-purpose registers.

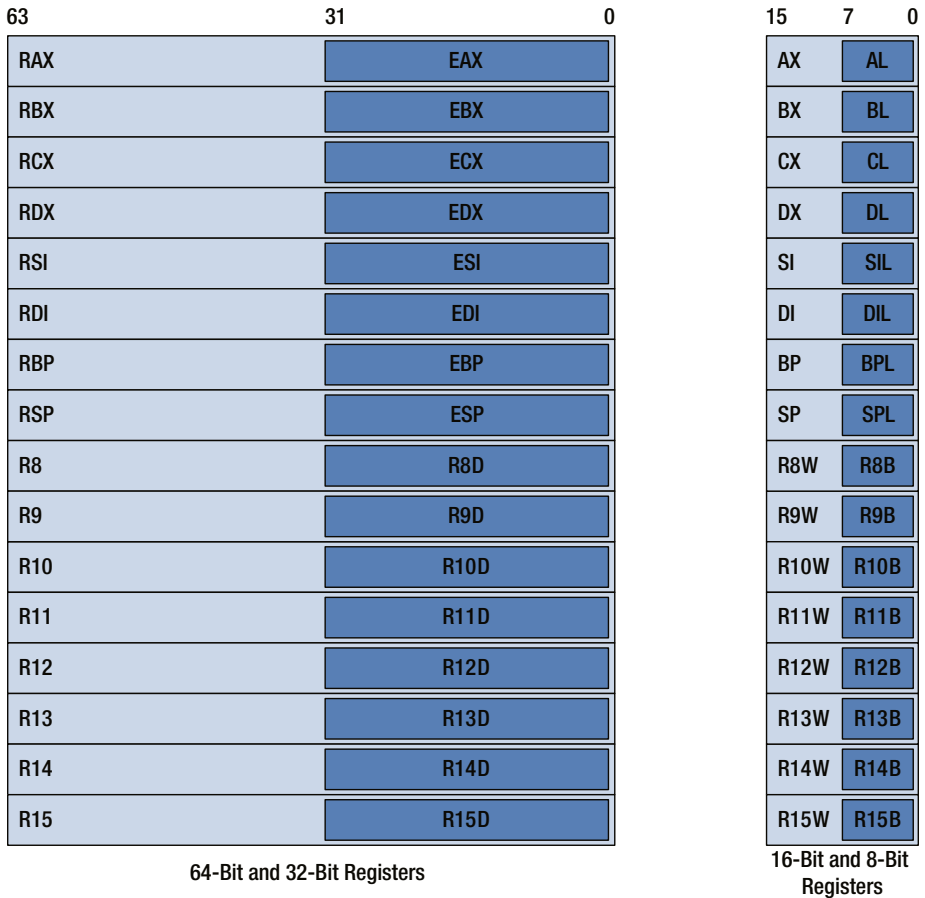

Figure 17-2. X86-64 general-purpose registers

It should be noted that a discrepancy exists regarding the names of the eight new byte registers. The Intel documentation refers to these registers as R8L-R15L. However, the Microsoft 64-bit assembler requires instructions to use the names that are shown in Figure 17-2. This book uses the names R8B-R15B in order to maintain consistency between the text and the sample code. The x86-64 platform also supports use of the legacy registers AH, BH, CH, and DH, albeit with some restrictions. These restrictions are discussed later in this chapter.

Similar to the x86-32 instruction set, the x86-64 instruction set includes some constraints on how the 64-bit registers can be used. For example, the single operand version of the `imul` instruction always returns a 128-bit product in register pair RDX:RAX. The `idiv` instruction requires its 128-bit dividend to be loaded in register pair RDX:RAX;

the 64-bit quotient and remainder are saved to RAX and RDX, respectively. All string instructions must use RSI and RDI as pointers to the source and destination strings, and any string instruction that employs a repeat prefix must use register RCX as the counter. Finally, the 64-bit rotate and shift instructions are required to use register CL to carry out variable-bit operations.

The processor uses the stack pointer register RSP to support function calls and returns. The `call` and `ret` instructions carry out their stack write and read operations using 64-bit wide operands. The `push` and `pop` instructions also use 64-bit operands. This means that the location of the stack in memory is usually aligned to an 8-byte boundary. Some run-time environments align the stack and RSP to a 16-byte boundary in order to enable aligned data transfers to and from an XMM register. Register RBP can be used as a stack frame pointer or as a general-purpose register.

RFLAGS Register

The RFLAGS register is a 64-bit wide register that contains various processor status flags and control bits. The low-order 32 bits of this register correspond to the EFLAGS register; the function of the auxiliary carry flag (AF), carry flag (CF), overflow flag (OF), parity flag (PF), sign flag (SF), and zero flag (ZF) are unchanged. The high-order 32-bits of RFLAGS are reserved for future use. The `pushfq` and `popfq` instructions can be used to push or pop RFLAGS onto or from the stack, respectively.

Instruction Pointer Register

The 64-bit RIP register contains the offset of the next instruction to be executed. Like its 32-bit counterpart, RIP is implicitly manipulated by the control-transfer instructions `call`, `ret`, `jmp`, and `jcc`. The processor also uses the RIP register to support a new memory operand addressing mode, which is discussed later in this chapter. It is not possible for a task to directly access the RIP register.

Instruction Operands

Most x86-64 instructions use operands, which designate the specific values that are acted upon. Nearly all instructions require a single destination operand along with one or more source operands. Most instructions require explicit specification of the source and destination operands. However, a number of x86-64 instructions use implicit or forced operands. X86-64 mode supports the same three basic operand types as x86-32 mode: immediate, register, and memory. Table 17-1 shows examples of instructions that illustrate the various operand types.

Table 17-1. Examples of Basic Operand Types

Type	Example	Equivalent C/C++ Statement
Immediate	<code>mov rax,42</code>	<code>rax = 42</code>
	<code>imul r12,-47</code>	<code>r12 *= -47</code>
	<code>shl r15,8</code>	<code>r15 <<= 8</code>
	<code>xor ecx,80000000h</code>	<code>ecx ^= 0x80000000</code>
	<code>sub r9b,14</code>	<code>r9b -= 14</code>
Register	<code>mov rax,rbx</code>	<code>rax = rbx</code>
	<code>add rbx,r10</code>	<code>rbx += r10</code>
	<code>mul rbx</code>	<code>rdx:rax = rax * rbx</code>
	<code>and r8w,0ff00h</code>	<code>r8w &= 0xff00</code>
Memory	<code>mov rax,[r13]</code>	<code>rax = *r13</code>
	<code>or rcx,[rbx+r10*8]</code>	<code>rcx = *(rbx+r10*8)</code>
	<code>mov qword ptr [r8],17</code>	<code>*(long long*)r8 = 17</code>
	<code>shl word ptr [r12],2</code>	<code>*(short*)r12 <<= 2</code>

Memory Addressing Modes

The x86-64 instruction set requires up to four separate components in order to specify the location of an operand in memory. The four components include a constant displacement value, a base register, an index register, and a scale factor. Using these components, the processor calculates an effective address for a memory operand as follows:

$$\text{EffectiveAddress} = \text{BaseReg} + \text{IndexReg} * \text{ScaleFactor} + \text{Disp}$$

When calculating an x86-64 effective address, the processor uses the four effective address components in a manner that's similar to an x86-32 effective address calculation. The base register (BaseReg) can be any general-purpose register. The index register (IndexReg) can be any general-purpose register except RSP. Valid scale factors (ScaleFactor) include 1, 2, 4, and 8. Finally, the displacement (Disp) is a constant 8-bit, 16-bit or 32-bit signed offset that's encoded within the instruction. Table 17-2 illustrates the various x86-64 memory addressing modes using different forms of the `mov` instruction. Note that it is not necessary to explicitly specify all of the components required for an effective address calculation. The final size of an effective address calculation is always 64 bits.

Table 17-2. X86-64 Memory Operand Addressing Forms

Addressing Form	Example
RIP + Disp	mov rax,[Val]
BaseReg	mov rax,[rbx]
BaseReg + Disp	mov rax,[rbx+16]
IndexReg * SF + Disp	mov rax,[r15*8+48]
BaseReg + IndexReg	mov rax,[rbx+r15]
BaseReg + IndexReg + Disp	mov rax,[rbx+r15+32]
BaseReg + IndexReg * SF	mov rax,[rbx+r15*8]
BaseReg + IndexReg * SF + Disp	mov rax,[rbx+r15*8+64]

The x86-64 instruction set also uses a new addressing mode to compute the effective address of a static operand in memory. The `mov rax,[Val]` instruction that's shown in the first row of Table 17-2 is an example of RIP-relative (or instruction pointer relative) addressing. With RIP-relative addressing, the processor calculates an effective address using the contents of the RIP register and a signed 32-bit displacement value that's encoded within the instruction. Figure 17-3 illustrates this calculation in greater detail. RIP-relative addressing allows the processor to reference a static operand using a 32-bit displacement instead of a 64-bit displacement, which saves code space. It also facilitates position-independent code. (The little-endian byte ordering that's shown in Figure 17-3 is discussed in Chapter 1 and illustrated in Figure 1-1.)

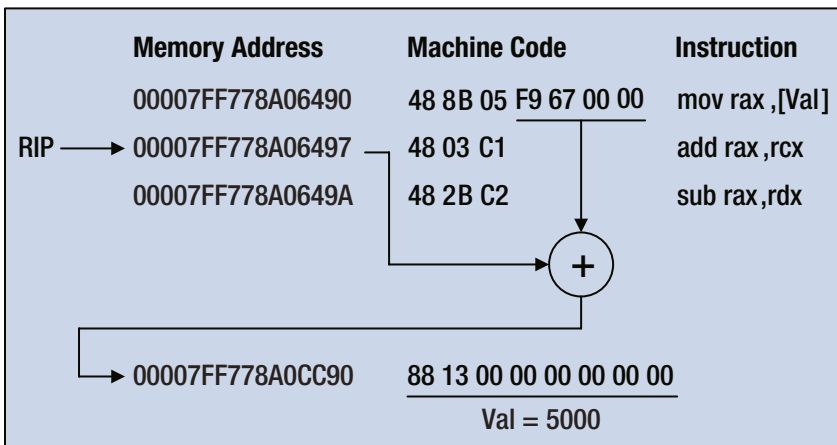

Note: Machine code uses little-endian byte ordering for displacement of Val.

Figure 17-3. Illustration of RIP-relative effective address calculation

The one limitation of RIP-relative addressing is that the target operand must reside within a ± 2 GB address window of the RIP register. For most programs, this limitation is rarely a concern. The calculation of a RIP-relative displacement value is usually determined automatically by the assembler during code generation. This means that you can use instructions such as `mov eax, [MyVal]` without having to worry about the details of the displacement value calculation.

Differences Between X86-64 and X86-32

Most existing x86-32 instructions have an x86-64 equivalent instruction that enables a function to exploit 64-bit wide addresses and operands. An x86-64 function can also perform calculations using instructions that manipulate 8-bit, 16-bit, or 32-bit registers and operands. Except for the `mov` instruction, the maximum size of an x86-64 mode immediate value is 32 bits. If an instruction manipulates a 64-bit wide register or memory operand, any specified 32-bit immediate value is signed-extended to 64 bits prior to its use.

The immediate value size limitation warrants some extra discussion since it affects the instruction sequences that a program must use to carry out certain operations. Figure 17-4 contains a few examples of instructions that use a 64-bit register with an immediate operand. In the first example, the `mov rax, 100` instruction loads an immediate value into the RAX register. Note that the machine code uses only 32 bits to encode the immediate value 100. This value is signed-extended to 64 bits and saved in RAX. The `add rax, 200` instruction that follows also sign-extends its immediate value to 64 bits prior to performing the addition. The next example opens with a `mov rcx, -2000` instruction that loads a negative immediate value into RCX. The machine code for this instruction also uses only 32 bits to encode the immediate value -2000, which is signed-extended to 64 bits and saved in RCX. The subsequent `add rcx, 1000` instruction yields a 64-bit result of -1000.

Machine Code	Instruction	DesOp Result
48 C7 C0 <u>64 00 00 00</u>	mov rax,100	0000000000000064h
48 05 C0 <u>C8 00 00 00</u>	add rax,200	000000000000012Ch
48 C7 C1 <u>30 F8 FF FF</u>	mov rcx,-2000	FFFFFFFFFFFFFF830h
48 81 C1 <u>E8 03 00 00</u>	add rcx,1000	FFFFFFFFFFFFFFC18h
48 C7 C2 <u>FF 00 00 00</u>	mov rdx,0ffh	00000000000000FFh
48 81 CA <u>00 00 00 80</u>	or rdx,80000000h	FFFFFFFF800000FFh
48 C7 C2 <u>FF 00 00 00</u>	mov rdx,0ffh	00000000000000FFh
49 B8 <u>00 00 00 80 00 00 00 00</u>	mov r8,80000000h	0000000080000000h
49 0B D0	or rdx,r8	00000000800000FFh

Note: Machine code immediate values are underlined.

Figure 17-4. Examples of using 64-bit registers with immediate operands

The third example employs a `mov rdx,0ffh` instruction to initialize register RDX. This is followed by an `or rdx,80000000h` instruction that sign-extends the immediate value `0x80000000` to `0xFFFFFFFF80000000`, and then performs a logical bitwise inclusive OR operation. The value that's shown for RDX is almost certainly not the intended result. The final example illustrates how to carry out an operation that requires a 64-bit immediate value. A `mov r8,80000000h` instruction loads the 64-bit value `0x0000000080000000` into R8. As mentioned earlier in this section, the `mov` instruction is the only instruction that supports 64-bit immediate operands. Execution of the ensuing `or rdx,r8` instruction yields the correct value.

The 32-bit size limitation for immediate values also applies to `jmp` and `call` instructions that specify relative-displacement targets. In these cases, the target of a `jmp` or `call` instruction must reside within a ± 2 GB address window of the current RIP register. Program transfer control targets whose relative displacements exceed this window can only be accessed using a `jmp` or `call` instruction that employs an indirect operand (for example, `jmp qword ptr [FuncPtr]` or `call rax`). Like RIP-relative addressing, the size limitations described in this paragraph are unlikely to present obstacles for most assembly language functions.

Another difference between x86-32 and x86-64 mode is the effect that some instructions have on the upper 32 bits of a 64-bit general-purpose register. When using instructions that manipulate 32-bit registers and operands, high-order 32 bits of the corresponding 64-bit general-purpose register are zeroed during execution. For example, assume that register RAX contains the value `0x8000000000000000`. Execution of the

instruction `add eax,10` generates a result of `0x000000000000000A` in RAX. However, when working with 8-bit or 16-bit registers and operands, the upper 56 or 48 bits of the corresponding 64-bit general-purpose register are not modified. Assuming again that if RAX contains `0x8000000000000000`, execution of the instructions `add al,20` or `add ax,40` would yield RAX values of `0x8000000000000014` or `0x8000000000000028`, respectively.

The final x86-64 versus x86-32 difference worthy of mention involves the 8-bit registers AH, BH, CH, and DH. These registers cannot be used with instructions that also reference one of the new 8-bit registers (that is, SIL, DIL, BPL, SPL, and R8B-15B). Instructions that reference the original 8-bit registers such as `mov ah,bl` and `add dh,bl` can still be used by x86-64 programs. However, `mov ah,r8b` and `add dh,r8b` are invalid instructions.

Instruction Set Overview

The following section presents an overview of the x86-64 instruction set. It begins with a synopsis of basic instruction use. Next is a short summary of instructions that are no longer valid in x86-64 mode. This is followed by a quick review of instructions that are either new or whose operation is somewhat different in x86-64 mode. The section concludes with a discussion of deprecated x86-64 computational resources.

Basic Instruction Use

The x86-64 instruction set is a logical extension of the x86-32 instruction set. Most x86-32 instructions have been promoted to support 64-bit operands. In addition, 64-bit assembly language functions can still use instructions with 8-bit, 16-bit, and 32-bit operands, as illustrated in Table 17-3. Note that the memory operands in these example instructions are referenced using 64-bit registers, which is required in order to access the entire 64-bit effective address space. While it is possible in x86-64 mode to reference a memory operand using a 32-bit register (for example, `mov r10,[eax]`), the location of the operand must reside in the low 4GB portion of the 64-bit effective address space. Using 32-bit registers to access memory operands in x86-64 mode is not recommended since it introduces unnecessary code obfuscations and complicates software testing and debugging.

Table 17-3. Examples of X86-64 Instructions Using Various Operand Sizes

8-Bit	16-Bit	32-Bit	64-Bit
<code>add al,bl</code>	<code>add ax,bx</code>	<code>add eax,ebx</code>	<code>add rax,rbx</code>
<code>cmp dl,[r15]</code>	<code>cmp dx,[r15]</code>	<code>cmp edx,[r15]</code>	<code>cmp rdx,[r15]</code>
<code>mul r10b</code>	<code>mul r10w</code>	<code>mul r10d</code>	<code>mul r10</code>
<code>or [r8+rdi],al</code>	<code>or [r8+rdi*2],ax</code>	<code>or [r8+rdi*4],eax</code>	<code>or [r8+rdi*8],rax</code>
<code>shl r9b,cl</code>	<code>shl r9w,cl</code>	<code>shl r9d,cl</code>	<code>shl r9,cl</code>

Except for a few differences that are discussed later in this section, most of the x86-32 instruction descriptions presented in Chapter 1 also are applicable to x86-64 instruction use. Additional information regarding the x86-64 instruction set is available in the reference manuals published by Intel and AMD, which can be downloaded from their respective websites. Appendix C contains a list of these manuals.

Invalid Instructions

A handful of rarely used x86-32 instructions are invalid for use in x86-64 mode. Table 17-4 lists these instructions. Somewhat surprisingly, early-generation x86-64 processors did not support the `lahf` (Load Status Flags into AH Register) and `sahf` (Store AH into Flags) instructions in x86-64 mode (they still worked in x86-32 mode). Fortunately, these instructions were reinstated and should be available in most AMD and Intel processors marketed since 2006. A program can confirm processor support for the `lahf` and `sahf` instructions in x86-64 mode by testing the `cpuid` feature flag `LAHF/SAHF`.

Table 17-4. *X86-64 Mode Invalid Instructions*

Mnemonic	Name
<code>aaa</code>	ASCII Adjust After Addition
<code>aad</code>	ASCII Adjust Before Division
<code>aam</code>	ASCII Adjust After Multiplication
<code>aas</code>	ASCII Adjust After Subtraction
<code>bound</code>	Check Array Index Against Bounds
<code>daa</code>	Decimal Adjust After Addition
<code>das</code>	Decimal Adjust After Subtraction
<code>into</code>	Interrupt if EFLAGS.OF is 1
<code>popa/popad</code>	Pop All General-Purpose Registers
<code>pusha/pushad</code>	Push All General-Purpose Registers

New Instructions

The x86 instruction set includes a number of new instructions that carry out their operations using 64-bit wide operands. It also modifies the behavior of a few existing instructions. Table 17-5 summarizes these instructions and uses the acronym GPR for general-purpose register.

Table 17-5. X86-64 New Instructions

Mnemonic	Description
cdqe	Sign-extends the doubleword value in EAX and saves the result to RAX.
cmpsb cmpsw cmpsd cmpsq	Compares the values at the memory locations pointed to by registers RSI and RDI; sets the status flags to indicate the results.
cmpxchg16b	Compares RDX:RAX with an 16-byte memory operand and performs an exchange based on the results.
cqo	Sign-extends the contents of RAX to RDX:RAX.
jrcxz	Performs a jump to the specified memory location if the condition RCX == 0 is true.
lodsb lodsw lodsd lodsq	Loads the value at the memory location pointed to by register RSI into the AL, AX, EAX, or RAX register.
movsb movsw movsd movsq	Copies the value of the memory location specified by register RSI to the memory location specified by register RDI.
movxsb	Copies and sign-extends a doubleword value from the source operand and saves it to the destination operand.
pop	Pops the top-most item from the stack. This instruction copies the contents of the memory location pointed to by RSP to the specified GPR or memory location; RSP is then automatically adjusted to reflect the pop. This instruction cannot be used with 32-bit wide operands.
popfq	Pops the top-most quadword from the stack and saves the low-order doubleword to the low-order 32 bits of RFLAGS. The high-order 32 bits of RFLAGS are set to zero. This instruction does not modify reserved bits and certain control bits in RFLAGS.
push	Pushes a GPR, memory location, or immediate value onto the stack; RSP is automatically adjusted to reflect the push. This instruction cannot be used with 32-bit wide operands.
pushfq	Pushes RFLAGS onto the stack.

(continued)

Table 17-5. (continued)

Mnemonic	Description
rep repe/repz repne/repnz	Repeats the specified string instruction while $RCX \neq 0$ and the specified compare condition are true.
scasb scasw scasd scasq	Compares the value of the memory location specified by register RDI with the value contained in register AL, AX, EAX, or RAX; sets the status flags based on the comparison results.
stosb stosw stosd stosq	Stores the contents of register AL, AX, EAX, or RAX to the memory location specified by register RDI.

Deprecated Resources

Processors that support the x86-64 instruction set also include the computational resources of SSE2. This means that x86-64 programs can safely use the packed integer capabilities of SSE2 instead of MMX. It also means that x86-64 programs can use the scalar floating-point resources of SSE2 instead of the x87 FPU. Programs can still take advantage of the MMX and x87 FPU instruction sets in an x86-64 execution environment, and such use might be appropriate in a legacy code migration situation. For new software development, however, use of the MMX and x87 FPU instruction sets is not recommended.

Summary

In this chapter, you learned about the core architecture of the x86-64 platform, including its execution units, general-purpose registers, instruction operands, and memory-addressing modes. You also acquired important knowledge about the differences between the x86-64 and x86-32 execution environments and their associated instruction sets. In Chapter 18, you'll focus on learning the fundamentals of x86-64 assembly language programming using sample code that elucidates most of the topics presented in this chapter.



X86-64 Core Programming

In the previous chapter, you learned about the core architecture of the x86-64 platform, including its execution units, general-purpose registers, instruction operands, and memory-addressing modes. You also became versed regarding the differences between the x86-32 and x86-64 execution environments and their corresponding instruction sets. In this chapter, you focus on the basics of x86-64 assembly language programming.

The content of this chapter is organized as follows:

- The first section explains the basics of x86-64 assembly language programming, including how to perform integer arithmetic, use memory-addressing modes, and carry out scalar floating-point arithmetic.
- The next section elucidates the calling conventions that must be observed by an x86-64 assembly language function in order to be callable from a high-level language such as C++.
- The last section demonstrates x86-64 programming techniques using arrays and text strings.

All of the sample code in this chapter requires an x86-64 compatible processor and operating system.

X86-64 Programming Fundamentals

This section introduces the essentials of x86-64 assembly language programming. It begins with a brief overview of the calling convention that must be observed in order to call an x86-64 assembly language function from C++. This is followed by a sample program that illustrates how to perform basic integer arithmetic using the x86-64 instruction set. The second sample program exemplifies use of commonly-used memory-addressing modes. The final two sample programs elucidate use of integer operands and scalar floating-point arithmetic in an x86-64 function.

Like its 32-bit counterpart, the Visual C++ 64-bit run-time environment defines a calling convention that must be observed by an x86-64 assembly language function. The calling convention designates each processor general-purpose register as volatile or non-volatile. It also applies a volatile or non-volatile classification to each XMM register. An x86-64 assembly language function can modify the contents of any volatile register,

but it must preserve the contents of the non-volatile registers. Table 18-1 lists the 64-bit volatile and non-volatile registers. Other aspects of the Visual C++ calling convention are explained throughout this chapter. Appendix B also contains a complete summary of the calling convention.

Table 18-1. Visual C++ 64-bit Volatile and Non-Volatile Registers

Register Type	Volatile Registers	Non-Volatile Registers
General-purpose	RAX, RCX, RDX, R8, R9, R10, R11	RBX, RSI, RDI, RBP, RSP, R12, R13, R14, R15
X86-SSE XMM	XMM0-XMM5	XMM6-XMM15

On systems that support x86-AVX, the upper 128 bits of each YMM register are classified as volatile. Visual C++ 64-bit programs normally don't use the x87 FPU. X86-64 assembly language functions that use this resource are not required to preserve the contents of the x87 FPU register stack, which means that the entire register stack should be considered volatile.

Compared to the 32-bit calling convention, the Visual C++ 64-bit calling convention imposes stricter programming requirements on assembly language functions. These requirements vary depending on whether the function is a leaf or non-leaf function. Leaf functions are functions that:

- Do not call any other functions.
- Do not modify the contents of the RSP register.
- Do not allocate any local stack space.
- Do not modify any of the non-volatile general-purpose or XMM registers.
- Do not use exception handling.

X86-64 assembly language leaf functions are easier to code, but they're only suitable for relatively simple computational tasks. A non-leaf function can use the entire x86-64 register set, create a stack frame, allocate local stack space, or call other functions provided it complies with the calling convention's precise requirements for prologs and epilogs. The sample code in this section consists of leaf functions that illustrate the fundamentals of x86-64 assembly language programming. You learn how to create non-leaf functions later in this chapter.

Integer Arithmetic

The first sample program that you examine is called `IntegerArithmetic`, which demonstrates how to perform basic integer arithmetic using the x86-64 instruction set. This sample program also illustrates use of the fundamental conventions that specify

how argument values are passed from a C++ function to an x86-64 assembly language function. Listings 18-1 and 18-2 show the C++ and assembly language source code for sample program `IntegerArithmetic`.

Listing 18-1. `IntegerArithmetic.cpp`

```
#include "stdafx.h"
#include "MiscDefs.h"

extern "C" Int64 IntegerAdd_(Int64 a, Int64 b, Int64 c, Int64 d, Int64 e,
Int64 f);
extern "C" Int64 IntegerMul_(Int8 a, Int16 b, Int32 c, Int64 d, Int8 e,
Int16 f, Int32 g, Int64 h);
extern "C" void IntegerDiv_(Int64 a, Int64 b, Int64 quo_rem_ab[2], Int64 c,
Int64 d, Int64 quo_rem_cd[2]);

void IntegerAdd(void)
{
    Int64 a = 100;
    Int64 b = 200;
    Int64 c = -300;
    Int64 d = 400;
    Int64 e = -500;
    Int64 f = 600;

    // Calculate a + b + c + d + e + f
    Int64 sum = IntegerAdd_(a, b, c, d, e, f);

    printf("\nResults for IntegerAdd\n");
    printf("a: %5lld b: %5lld c: %5lld\n", a, b, c);
    printf("d: %5lld e: %5lld f: %5lld\n", d, e, f);
    printf("sum: %lld\n", sum);
}

void IntegerMul(void)
{
    Int8 a = 2;
    Int16 b = -3;
    Int32 c = 8;
    Int64 d = 4;
    Int8 e = 3;
    Int16 f = -7;
    Int32 g = -5;
    Int64 h = 10;

    // Calculate a * b * c * d * e * f * g * h
    Int64 result = IntegerMul_(a, b, c, d, e, f, g, h);
}
```

```

    printf("\nResults for IntegerMul\n");
    printf("a: %5d b: %5d c: %5d d: %5lld\n", a, b, c, d);
    printf("e: %5d f: %5d g: %5d h: %5lld\n", e, f, g, h);
    printf("result: %5lld\n", result);
}

void IntegerDiv(void)
{
    Int64 a = 102;
    Int64 b = 7;
    Int64 quo_rem_ab[2];
    Int64 c = 61;
    Int64 d = 9;
    Int64 quo_rem_cd[2];

    // Calculate a / b and c / d
    IntegerDiv_(a, b, quo_rem_ab, c, d, quo_rem_cd);

    printf("\nResults for IntegerDiv\n");
    printf("a: %5lld b: %5lld ", a, b);
    printf("quo: %5lld rem: %5lld\n", quo_rem_ab[0], quo_rem_ab[1]);
    printf("c: %5lld d: %5lld ", c, d);
    printf("quo: %5lld rem: %5lld\n", quo_rem_cd[0], quo_rem_cd[1]);
}

int _tmain(int argc, _TCHAR* argv[])
{
    IntegerAdd();
    IntegerMul();
    IntegerDiv();
    return 0;
}

```

Listing 18-2. IntegerArithmetic.asm

```

    .code

; extern "C" Int64 IntegerAdd_(Int64 a, Int64 b, Int64 c, Int64 d, Int64 e,
Int64 f)
;
; Description: The following function demonstrates 64-bit integer
;              addition.

IntegerAdd_proc

; Calculate sum of argument values
    add rcx,rdx                ;rcx = a + b
    add r8,r9                 ;r8 = c + d

```



```

    mov rax,[rsp+40]           ;rax = e
    add rax,[rsp+48]         ;rax = e + f

    add rcx,r8               ;rcx = a + b + c + d
    add rax,rcx              ;rax = a + b + c + d + e + f

    ret
IntegerAdd_ endp

; extern "C" Int64 IntegerMul_(Int8 a, Int16 b, Int32 c, Int64 d, Int8 e,
Int16 f, Int32 g, Int64 h);
;
; Description: The following function demonstrates 64-bit signed
;               integer multiplication.

IntegerMul_ proc

; Calculate a * b
    movsx r10,cl              ;r10 = sign_extend(a)
    movsx r11,dx              ;r11 = sign_extend(b)
    imul r10,r11              ;r10 = a * b

;Calculate c * d
    movsxd rcx,r8d            ;rcx = sign_extend(c)
    imul rcx,r9               ;rcx = c * d

; Calculate e * f
    movsx r8,byte ptr [rsp+40] ;r8 = sign_extend(e)
    movsx r9,word ptr [rsp+48] ;r9 = sign_extend(f)
    imul r8,r9                ;r8 = e * f

; Calculate g * h
    movsxd rax,dword ptr [rsp+56] ;rax = sign_extend (g)
    imul rax,[rsp+64]          ;rax = g * h

; Compute final result
    imul r10,rcx              ;r10 = a * b * c * d
    imul rax,r8                ;rax = e * f * g * h
    imul rax,r10               ;rax = final product

    ret
IntegerMul_ endp

; extern "C" void IntegerDiv_(Int64 a, Int64 b, Int64 quo_rem_ab[2],
Int64 c, Int64 d, Int64 quo_rem_cd[2]);
;
; Description: The following function demonstrates 64-bit signed
;               integer division.

```

IntegerDiv_ proc

```

; Calculate a / b, save quotient and remainder
    mov [rsp+16],rdx          ;save b
    mov rax,rcx              ;rax = a
    cqo                      ;rdx:rax = sign_extend(a)
    idiv qword ptr [rsp+16]  ;rax = quo a/b, rdx = rem a/b
    mov [r8],rax             ;save quotient
    mov [r8+8],rdx          ;save remainder

; Calculate c / d, save quotient and remainder
    mov rax,r9               ;rax = c
    cqo                      ;rdx:rax = sign_extend(c)
    idiv qword ptr [rsp+40]  ;rax = quo c/d, rdx = rem c/d
    mov r10,[rsp+48]         ;r10 = ptr to quo_rem_cd
    mov [r10],rax            ;save quotient
    mov [r10+8],rdx         ;save remainder

    ret
IntegerDiv_ endp
end

```

The C++ file `IntegerArithmetic.cpp` (see Listing 18-1) includes the header file `MiscDefs.h`, which contains a series of typedef statements for sized integer types. This is the same header file that was used by the 32-bit C++ sample code. The remainder of `IntegerArithmetic.cpp` contains three simple functions that perform test variable initialization, assembly language function execution, and results presentation. The primary purpose of the assembly language functions is to illustrate 64-bit argument passing, the layout of the stack, and 64-bit integer arithmetic.

Listing 18-2 shows the x86-64 assembly language code for sample program `IntegerArithmetic`. Toward the top of the `IntegerArithmetic_asm` file is a `.code` directive, which defines the start of a code block. The `.model` directive that was used in the x86-32 assembly language source files is neither required nor supported by the 64-bit version of MASM. The `IntegerAdd_ proc` statement defines the entry point for the assembly language function `IntegerAdd_`, and the end of this function's code section is demarcated by the `IntegerAdd_ endp` statement.

The first four integer or pointer arguments of a 64-bit Visual C++ function are passed in registers RCX, RDX, R8, and R9. Any additional arguments are passed via the stack. The Visual C++ 64-bit calling convention requires the caller of a function to allocate 32 bytes of stack space for use by the called function. This *uninitialized* stack space, which is called the home area (or space), is primarily intended as a temporary storage area for argument values that are passed in registers. The home space can also be used by a called function to store other transient values. It should be noted that the caller of a function must always allocate 32 bytes of home space regardless of the number of actual argument values. Figure 18-1 illustrates layout of the stack and the argument registers at entry to `IntegerAdd_`.

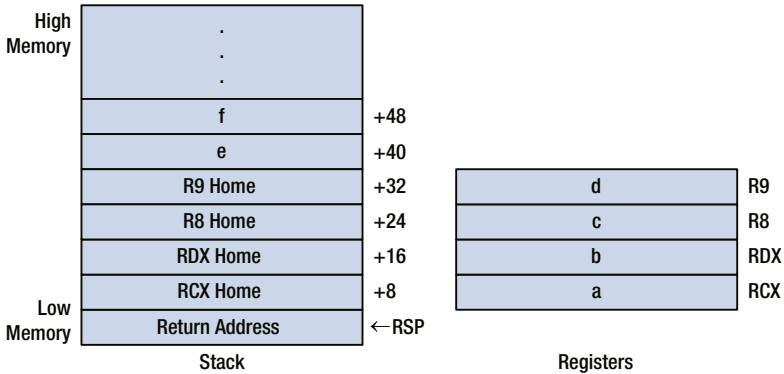

Figure 18-1. Stack layout and register contents at entry to function `IntegerAdd_`

The `IntegerAdd_` function returns the sum of its six 64-bit signed integer argument values. The first two instructions of this function, `add rcx, rdx` and `add r8, r9`, compute the sums `a + b` and `c + d`, respectively. A `mov rax, [rsp+40]` instruction then loads argument value `e` into register RAX. This is followed by an `add rax, [rsp+48]` instruction, which computes `e + f`. The next two instructions, `add rcx, r8` and `add rax, rcx`, compute the final sum. A 64-bit assembly language function must use the RAX register to return a 64-bit integer value to its caller. Since RAX already contains the final result, no additional `mov` instructions are necessary. The final instruction of `IntegerAdd_` is a `ret` instruction.

The next assembly language function, `IntegerMul_`, demonstrates how to perform integer multiplication. Figure 18-2 illustrates layout of the stack and argument registers at entry to `IntegerMul_`. Note that argument values shorter than 64 bits are right-justified, either in a register or on the stack, and the high-order bits are undefined.

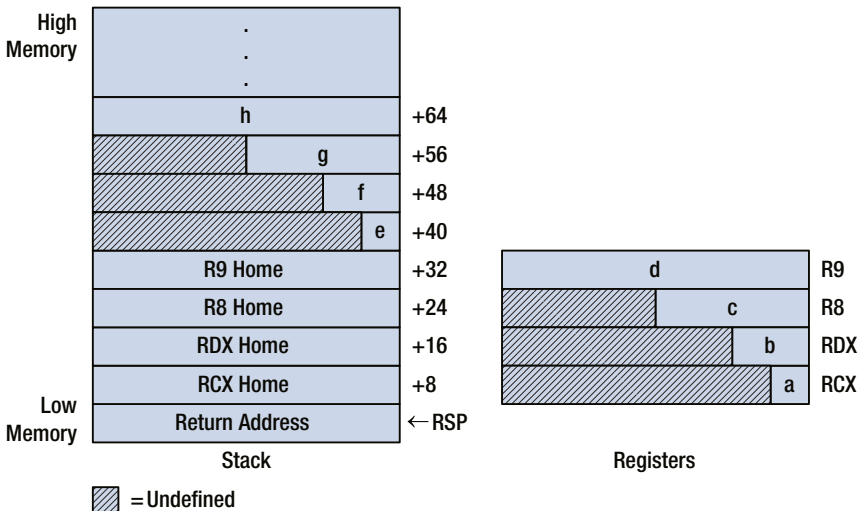

Figure 18-2. Stack layout and register contents at entry to function `IntegerMul_`

The `IntegerMul_` function computes the product of its eight signed integer argument values. It begins with a `movsx r10, c1` instruction, which loads a sign-extended copy of argument value `a` into `R10`. A `movsx r11, dx` instruction performs a similar operation using the argument value `b`. This is followed by an `imul r10, r11` instruction that computes `a * b`. The next two instructions, `movsxd rcx, r8d` and `imul r10, rcx, r9` calculate the product `c * d`. Note that the x86-64 instruction set defines a distinct mnemonic (`movsxd`) to perform a sign-extended move of a 32-bit value into a 64-bit register. Calculation of the intermediate products `e * f` and `g * h` occurs next using a series of `movsx`, `movsxd`, and `imul` instructions. The argument values `e`, `f`, `g`, and `h` are located on the stack and referenced using constant offsets relative to the `RSP` register. The final three `imul` instructions compute the final 64-bit product.

The final assembly language function is named `IntegerDiv_`. This function demonstrates how to perform 64-bit signed integer division. Figure 18-3 shows the layout of the stack at entry to `IntegerDiv_`. The first instruction of `IntegerDiv_`, `mov [rsp+16], rdx`, saves the contents of register `RDX` (or argument value `b`) to its home area on the stack. The next instruction, `mov rax, rcx`, copies the dividend value `a` into register `RAX`. A `cqo` (Convert Quadword to Double Quadword) instruction sign extends the contents of `RAX` to register pair `RDX:RAX`. This is followed by an `idiv qword ptr [rsp+16]` instruction that divides register pair `RDX:RAX` by the contents of `[rsp+16]` (or `a / b`). Following execution of the `idiv` instruction, registers `RAX` and `RDX` contain the quotient and remainder, respectively. These values are saved to the result array pointed to by `R8`, which corresponds to the argument variable `quo_rem_ab`. The next block of instructions computes `c / d` using a similar sequence of instructions. Output 18-1 shows the results of the sample program `IntegerArithmetic`.

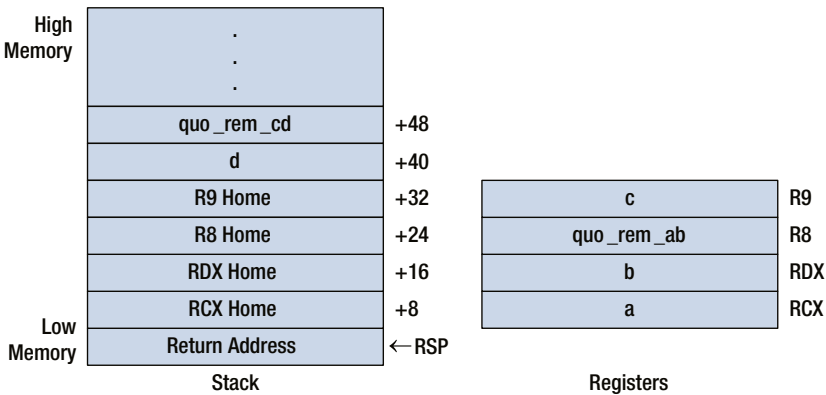

Figure 18-3. Stack layout and register contents at entry to function `IntegerDiv_`

Output 18-1. Sample Program IntegerArithmetic

Results for IntegerAdd

```
a:  100 b:  200 c: -300
d:  400 e: -500 f:   600
sum: 500
```

Results for IntegerMul

```
a:    2 b:   -3 c:    8 d:    4
e:    3 f:   -7 g:   -5 h:   10
result: -201600
```

Results for IntegerDiv

```
a:   102 b:    7 quo:   14 rem:    4
c:    61 d:    9 quo:    6 rem:    7
```

Memory Addressing

The next sample program is called `MemoryAddressing`, which exemplifies use of frequently-used x86-64 memory-addressing modes. This sample program is a 64-bit version of the 32-bit sample program that you examined in Chapter 2. Listings 18-3 and 18-4 contain the source code for sample program `MemoryAddressing`.

Listing 18-3. `MemoryAddressing.cpp`

```
#include "stdafx.h"

extern "C" int NumFibVals_, FibValsSum_;
extern "C" int MemoryAddressing_(int i, int* v1, int* v2, int* v3, int* v4);

int _tmain(int argc, _TCHAR* argv[])
{
    FibValsSum_ = 0;

    for (int i = -1; i < NumFibVals_ + 1; i++)
    {
        int v1 = -1, v2 = -1, v3 = -1, v4 = -1;
        int rc = MemoryAddressing_(i, &v1, &v2, &v3, &v4);

        printf("i: %2d rc: %2d - ", i, rc);
        printf("v1: %5d v2: %5d v3: %5d v4: %5d\n", v1, v2, v3, v4);
    }

    printf("FibValsSum_: %d\n", FibValsSum_);
    return 0;
}
```

Listing 18-4. MemoryAddressing_.asm

```

; Simple lookup table (.const section data is read only)

        .const
FibVals    dword 0, 1, 1, 2, 3, 5, 8, 13
           dword 21, 34, 55, 89, 144, 233, 377, 610, 987, 1597
NumFibVals_ dword ($ - FibVals) / sizeof dword
           public NumFibVals_

        .data
FibValsSum_ dword ?           ;value to demo RIP-relative addressing
           public FibValsSum_

        .code

; extern "C" int MemoryAddressing_(int i, int* v1, int* v2, int* v3, ←
int* v4);
;
; Description: This function demonstrates various addressing modes
;              that can be used to access operands in memory.
;
; Returns:     0 = error (invalid table index)
;              1 = success

MemoryAddressing_ proc

; Make sure 'i' is valid
        cmp ecx,0
        jl InvalidIndex           ;jump if i < 0
        cmp ecx,[NumFibVals_]
        jge InvalidIndex         ;jump if i >= NumFibVals_

; Sign extend i for use in address calculations
        movsxd rcx,ecx           ;sign extend i
        mov [rsp+8],rcx         ;save copy of i

; Example #1 - base register
        mov r11,offset FibVals   ;r11 = FibVals
        shl rcx,2                ;rcx = i * 4
        add r11,rcx              ;r11 = FibVals + i * 4
        mov eax,[r11]            ;eax = FibVals[i]
        mov [rdx],eax            ;Save to v1

; Example #2 - base register + index register
        mov r11,offset FibVals   ;r11 = FibVals
        mov rcx,[rsp+8]          ;rcx = i

```

```

    shl rcx,2                ;rcx = i * 4
    mov eax,[r11+rcx]       ;eax = FibVals[i]
    mov [r8],eax           ;Save to v2

; Example #3 - base register + index register * scale factor
    mov r11,offset FibVals   ;r11 = FibVals
    mov rcx,[rsp+8]         ;rcx = i
    mov eax,[r11+rcx*4]     ;eax = FibVals[i]
    mov [r9],eax           ;Save to v3

; Example #4 - base register + index register * scale factor + disp
    mov r11,offset FibVals-42 ;r11 = FibVals - 42
    mov rcx,[rsp+8]         ;rcx = i
    mov eax,[r11+rcx*4+42]  ;eax = FibVals[i]
    mov r10,[rsp+40]       ;r10 = ptr to v4
    mov [r10],eax          ;Save to v4

; Example #5 - RIP relative
    add [FibValsSum_],eax   ;Update sum

    mov eax,1               ;set success return code
    ret

InvalidIndex:
    xor eax,eax             ;set error return code
    ret

MemoryAddressing_ endp
end

```

In the source code file `MemoryAddressing.cpp` (see Listing 18-3), the `_tmain` function contains a simple loop that exercises the assembly language function `MemoryAddressing_`. This function uses the index value `i` to select values from an array of 32-bit integers. Following each call to `MemoryAddressing_`, the integer variables `v1`, `v2`, `v3`, and `v4` contain the results of accessing the array using different addressing modes. These values are then displayed using the `printf` function for comparison purposes.

Toward the top of the `MemoryAddressing_.asm` file (see Listing 18-4) is an array named `FibVals`. This array contains a set of 32-bit constant integer values that are accessed using different memory-addressing modes. Next is a `.data` section that contains a 32-bit integer named `FibValsSum_`, which is used to demonstrate RIP-relative addressing. The `MemoryAddressing_` function begins its execution by validating the argument value `i` that's contained in register `ECX`. A `movsxd rcx,ecx` instruction sign extends `i` from 32 bits to 64 bits since this value is used to calculate the address of an element in `FibVals`. It's then saved to the `RCX` home area on the stack for later use.

The remaining instructions in the `MemoryAddressing_` function illustrate how to access the specified element in `FibVals` using different memory-addressing modes. The addressing modes used here are essentially the same as those employed in the 32-bit version of function `MemoryAddressing_`, except for the use of 64-bit address

registers. Note that the operand in each `mov r11,offset FibVals` instruction is a 64-bit immediate value. All other x86-64 instructions use 32-bit immediate values as discussed in Chapter 17. In the `MemoryAddressing_` function, the `cmp ecx,[NumFibvals_]` and `add [FibValsSum_],eax` instructions are examples of RIP-relative addressing. Output 18-2 shows the results of the sample program `MemoryAddressing`.

Output 18-2. Sample Program `MemoryAddressing`

```
i: -1 rc: 0 - v1: -1 v2: -1 v3: -1 v4: -1
i: 0 rc: 1 - v1: 0 v2: 0 v3: 0 v4: 0
i: 1 rc: 1 - v1: 1 v2: 1 v3: 1 v4: 1
i: 2 rc: 1 - v1: 1 v2: 1 v3: 1 v4: 1
i: 3 rc: 1 - v1: 2 v2: 2 v3: 2 v4: 2
i: 4 rc: 1 - v1: 3 v2: 3 v3: 3 v4: 3
i: 5 rc: 1 - v1: 5 v2: 5 v3: 5 v4: 5
i: 6 rc: 1 - v1: 8 v2: 8 v3: 8 v4: 8
i: 7 rc: 1 - v1: 13 v2: 13 v3: 13 v4: 13
i: 8 rc: 1 - v1: 21 v2: 21 v3: 21 v4: 21
i: 9 rc: 1 - v1: 34 v2: 34 v3: 34 v4: 34
i: 10 rc: 1 - v1: 55 v2: 55 v3: 55 v4: 55
i: 11 rc: 1 - v1: 89 v2: 89 v3: 89 v4: 89
i: 12 rc: 1 - v1: 144 v2: 144 v3: 144 v4: 144
i: 13 rc: 1 - v1: 233 v2: 233 v3: 233 v4: 233
i: 14 rc: 1 - v1: 377 v2: 377 v3: 377 v4: 377
i: 15 rc: 1 - v1: 610 v2: 610 v3: 610 v4: 610
i: 16 rc: 1 - v1: 987 v2: 987 v3: 987 v4: 987
i: 17 rc: 1 - v1: 1597 v2: 1597 v3: 1597 v4: 1597
i: 18 rc: 0 - v1: -1 v2: -1 v3: -1 v4: -1
FibValsSum_: 4180
```

Integer Operands

Most x86-64 instructions can be used with operands ranging in size from 8 bits to 64 bits. The sample program `IntegerOperands` illustrates how to perform common bitwise logical operations using various sized integers. The C++ and assembly language source code for this sample program are shown in Listings 18-5 and 18-6.

Listing 18-5. `IntegerOperands.cpp`

```
#include "stdafx.h"
#include "MiscDefs.h"

// The following structure must match the structure that's
// declared in IntegerOperands_.asm.
typedef struct
```



```

{
    Uint8 a8;
    Uint16 a16;
    Uint32 a32;
    Uint64 a64;
    Uint8 b8;
    Uint16 b16;
    Uint32 b32;
    Uint64 b64;
} ClVal;

extern "C" void CalcLogical_(ClVal* cl_val, Uint8 c8[3], Uint16 c16[3],
Uint32 c32[3], Uint64 c64[3]);

int _tmain(int argc, _TCHAR* argv[])
{
    ClVal x;
    Uint8 c8[3];
    Uint16 c16[3];
    Uint32 c32[3];
    Uint64 c64[3];

    x.a8 = 0x81;                x.b8 = 0x88;
    x.a16 = 0xF0F0;            x.b16 = 0x0FF0;
    x.a32 = 0x87654321;        x.b32 = 0xF000F000;
    x.a64 = 0x0000FFFF00000000; x.b64 = 0x0000FFFF00008888;

    CalcLogical_(&x, c8, c16, c32, c64);

    printf("\nResults for CalcLogical()\n");

    printf("\n8-bit operations\n");
    printf("0x%02X & 0x%02X = 0x%02X\n", x.a8, x.b8, c8[0]);
    printf("0x%02X | 0x%02X = 0x%02X\n", x.a8, x.b8, c8[1]);
    printf("0x%02X ^ 0x%02X = 0x%02X\n", x.a8, x.b8, c8[2]);

    printf("\n16-bit operations\n");
    printf("0x%04X & 0x%04X = 0x%04X\n", x.a16, x.b16, c16[0]);
    printf("0x%04X | 0x%04X = 0x%04X\n", x.a16, x.b16, c16[1]);
    printf("0x%04X ^ 0x%04X = 0x%04X\n", x.a16, x.b16, c16[2]);

    printf("\n32-bit operations\n");
    printf("0x%08X & 0x%08X = 0x%08X\n", x.a32, x.b32, c32[0]);
    printf("0x%08X | 0x%08X = 0x%08X\n", x.a32, x.b32, c32[1]);
    printf("0x%08X ^ 0x%08X = 0x%08X\n", x.a32, x.b32, c32[2]);
}

```

```

    printf("\n64-bit operations\n");
    printf("0x%016llx & 0x%016llx = 0x%016llx\n", x.a64, x.b64, c64[0]);
    printf("0x%016llx | 0x%016llx = 0x%016llx\n", x.a64, x.b64, c64[1]);
    printf("0x%016llx ^ 0x%016llx = 0x%016llx\n", x.a64, x.b64, c64[2]);

    return 0;
}

```

Listing 18-6. IntegerOperands_.asm

```

; The following structure must match the structure that's
; declared in IntegerOperands.cpp. Note the version below
; includes "pad" bytes, which are needed to account for the
; member alignments performed by the C++ compiler.
ClVal struct
a8      byte ?
pad1    byte ?
a16     word ?
a32     dword ?
a64     qword ?
b8      byte ?
pad2    byte ?
b16     word ?
b32     dword ?
b64     qword ?
ClVal  ends

        .code

; extern "C" void CalcLogical_(ClVal* cl_val, Uint8 c8[3], Uint16 c16[3],
; Uint32 c32[3], Uint64 c64[3]);
;
; Description: The following function demonstrates logical operations
;              using different sizes of integers.

CalcLogical_ proc

; 8-bit logical operations
    mov r10b,[rcx+ClVal.a8]           ;r10b = a8
    mov r11b,[rcx+ClVal.b8]           ;r11b = b8
    mov al,r10b
    and al,r11b                       ;calc a8 & b8
    mov [rdx],al
    mov al,r10b
    or al,r11b                         ;calc a8 | b8
    mov [rdx+1],al
    mov al,r10b
    xor al,r11b                       ;calc a8 ^ b8
    mov [rdx+2],al

```

```

; 16-bit logical operations
    mov rdx,r8                ;rdx = ptr to c16
    mov r10w,[rcx+ClVal.a16]  ;r10w = a16
    mov r11w,[rcx+ClVal.b16]  ;r11w = b16
    mov ax,r10w
    and ax,r11w                ;calc a16 & b16
    mov [rdx],ax
    mov ax,r10w
    or ax,r11w                 ;calc a16 | b16
    mov [rdx+2],ax
    mov ax,r10w
    xor ax,r11w                ;calc a16 ^ b16
    mov [rdx+4],ax

; 32-bit logical operations
    mov rdx,r9                ;rdx = ptr to c32
    mov r10d,[rcx+ClVal.a32]  ;r10d = a32
    mov r11d,[rcx+ClVal.b32]  ;r11d = b32
    mov eax,r10d
    and eax,r11d               ;calc a32 & b32
    mov [rdx],eax
    mov eax,r10d
    or eax,r11d                ;calc a32 | b32
    mov [rdx+4],eax
    mov eax,r10d
    xor eax,r11d               ;calc a32 ^ b32
    mov [rdx+8],eax

; 64-bit logical operations
    mov rdx,[rsp+40]          ;rdx = ptr to c64
    mov r10,[rcx+ClVal.a64]   ;r10 = a64
    mov r11,[rcx+ClVal.b64]   ;r11 = b64
    mov rax,r10
    and rax,r11                ;calc a64 & b64
    mov [rdx],rax
    mov rax,r10
    or rax,r11                 ;calc a64 | b64
    mov [rdx+8],rax
    mov rax,r10
    xor rax,r11                ;calc a64 ^ b64
    mov [rdx+16],rax

    ret
CalcLogical_ endp
end

```

Toward the top of the `IntegerOperands.cpp` file (see Listing 18-5) is a structure declaration named `C1Val` that contains standard-sized integer members. This structure is used to pass source operands to the assembly language function `CalcLogical_`. The `_tmain` function initializes an instance of `C1Val`, calls `CalcLogical_`, and displays the results.

The assembly language version of structure `C1Val` is declared in the `IntegerOperands_.asm` file (see Listing 18-6). When declaring structures, it is important to keep in mind that most C++ compilers will, by default, pad a structure in order to ensure proper alignment of multi-byte values. In the current program, the Visual C++ compiler adds extra bytes to properly align structure members `a16` and `b16`. Assembly language structure declarations, however, are not automatically padded for proper alignment. This accounts for the additional structure members `pad1` and `pad2` in the assembly language version of `C1Val`.

Inside the `CalcLogical_` function are four independent code blocks that carry out bitwise logical operations using various sized integer operands. The result of each logical operation is saved to the corresponding result array. This function also illustrates proper use of the suffixes that must be used to reference the low-order byte, word, and doubleword of registers R8-R15. Output 18-3 shows the results of the sample program `IntegerOperands`.

Output 18-3. Sample Program `IntegerOperands`

Results for `CalcLogical()`

8-bit operations

`0x81 & 0x88 = 0x80`

`0x81 | 0x88 = 0x89`

`0x81 ^ 0x88 = 0x09`

16-bit operations

`0xF0F0 & 0xFF0 = 0x00F0`

`0xF0F0 | 0xFF0 = 0xFFFF0`

`0xF0F0 ^ 0xFF0 = 0xFF00`

32-bit operations

`0x87654321 & 0xF00F00 = 0x80004000`

`0x87654321 | 0xF00F00 = 0xF765F321`

`0x87654321 ^ 0xF00F00 = 0x7765B321`

64-bit operations

`0x0000FFFF00000000 & 0x0000FFFF00008888 = 0x0000FFFF00000000`

`0x0000FFFF00000000 | 0x0000FFFF00008888 = 0x0000FFFF00008888`

`0x0000FFFF00000000 ^ 0x0000FFFF00008888 = 0x0000000000008888`

Floating-Point Arithmetic

In Chapter 17 you learned that all x86-64 compatible processors include the scalar floating-point resources of SSE2, which means that you can perform floating-point arithmetic using the XMM registers instead of the x87 FPU. The availability of SSE2 also facilitates use of the XMM registers for scalar floating-point function argument and return values. The sample program in this section is called `FloatingPointArithmetic` and illustrates how to perform scalar floating-point arithmetic in an x86-64 assembly language function. Listings 18-7 and 18-8 show the source code for sample program `FloatingPointArithmetic`.

Listing 18-7. `FloatingPointArithmetic.cpp`

```
#include "stdafx.h"

extern "C" double CalcSum_(float a, double b, float c, double d, float e,
double f);
extern "C" double CalcDist_(int x1, double x2, long long y1, double y2,
float z1, short z2);

void CalcSum(void)
{
    float a = 10.0f;
    double b = 20.0;
    float c = 0.5f;
    double d = 0.0625;
    float e = 15.0f;
    double f = 0.125;

    double sum = CalcSum_(a, b, c, d, e, f);

    printf("\nResults for CalcSum()\n");
    printf("a: %10.4f b: %10.4lf c: %10.4f\n", a, b, c);
    printf("d: %10.4lf e: %10.4f f: %10.4lf\n", d, e, f);
    printf("\nsum: %10.4lf\n", sum);
}

void CalcDist(void)
{
    int x1 = 5;
    double x2 = 12.875;
    long long y1 = 17;
    double y2 = 23.1875;
    float z1 = -2.0625;
    short z2 = -6;

    double dist = CalcDist_(x1, x2, y1, y2, z1, z2);
```

```

    printf("\nResults for CalcDist()\n");
    printf("x1: %10d  x2: %10.4lf\n", x1, x2);
    printf("y1: %10lld  y2: %10.4lf\n", y1, y2);
    printf("z1: %10.4f  z2: %10d\n", z1, z2);
    printf("\ndist: %12.6lf\n", dist);
}

int _tmain(int argc, _TCHAR* argv[])
{
    CalcSum();
    CalcDist();
    return 0;
}

```

Listing 18-8. FloatingPointArithmetic.asm

```

        .code

; extern "C" double CalcSum_(float a, double b, float c, double d, float e,
double f);
;
; Description: The following function demonstrates how to access
;               floating-point argument values in an x86-64 function.

CalcSum_ proc

; Sum the argument values
        cvtss2sd xmm0,xmm0                ;promote a to DFPF
        addsd xmm0,xmm1                   ;xmm0 = a + b

        cvtss2sd xmm2,xmm2                ;promote c to DFPF
        addsd xmm0,xmm2                   ;xmm0 = a + b + c
        addsd xmm0,xmm3                   ;xmm0 = a + b + c + d

        cvtss2sd xmm4,real4 ptr [rsp+40]  ;promote e to DFPF
        addsd xmm0,xmm4                   ;xmm0 = a + b + c + d + e

        addsd xmm0,real8 ptr [rsp+48]     ;xmm0 = a + b + c + d + e + f

        ret
CalcSum_ endp

; extern "C" double CalcDist_(int x1, double x2, long long y1, double y2,
float z1, short z2);
;
; Description: The following function demonstrates how to access mixed
;               floating-point and integer arguments values in an
;               x86-64 function.

```

```

CalcDist_ proc

; Calculate xd = (x2 - x1) * (x2 - x1)
    cvtsi2sd xmm4,ecx                ;convert x1 to DPF
    subsd xmm1,xmm4                ;xmm1 = x2 - x1
    mulsd xmm1,xmm1                ;xmm1 = xd

; Calculate yd = (y2 - y1) * (y2 - y1)
    cvtsi2sd xmm5,r8                ;convert y1 to DPF
    subsd xmm3,xmm5                ;xmm3 = y2 - y1
    mulsd xmm3,xmm3                ;xmm3 = yd

; Calculate zd = (z2 - z1) * (z2 - z1)
    movss xmm0,real4 ptr [rsp+40]    ;xmm0 = z1
    cvtss2sd xmm0,xmm0              ;convert z1 to DPF
    movsx eax,word ptr [rsp+48]      ;eax = sign-extend z2
    cvtsi2sd xmm4,eax                ;convert z2 to DPF
    subsd xmm4,xmm0                  ;xmm4 = z2 - z1
    mulsd xmm4,xmm4                  ;xmm4 = zd

; Calculate final distance sqrt(xd + yd + zd)
    addsd xmm1,xmm3                  ;xmm1 = xd + yd
    addsd xmm4,xmm1                  ;xmm4 = xd + yd + zd
    sqrtsd xmm0,xmm4                 ;xmm0 = sqrt(xd + yd + zd)

    ret
CalcDist_ endp
end

```

The `FloatingPointArithmetic.cpp` file (see Listing 18-7) contains two functions that set up test cases for the assembly language functions `CalcSum_` and `CalcDist_`. Note that the former function's declaration includes only floating-point values while the latter function specifies a combination of floating-point and integer values. The purpose of these functions is to illustrate how the Visual C++ calling convention handles different types of numerical values.

According to the Visual C++ calling convention, the first four floating-point arguments are passed to a function using registers XMM0-XMM3. Any additional floating-point arguments are passed via the stack. If a function requires a combination of integer and floating-point arguments, the first four values (integer or floating-point) are passed using either a general-purpose or XMM register; any remaining arguments are passed on the stack. The calling convention treats registers XMM0-XMM5 as volatile and registers XMM6-XMM15 as non-volatile. A function must use register XMM0 to return a floating-point value to its caller.

Listing 18-8 contains the x86-64 assembly language source code for function `CalcSum_`. This function computes the sum of its six floating-point arguments. Figure 18-4 shows the contents of the stack and argument registers at entry to `CalcSum_`. Registers XMM0-XMM4 contain argument values *a*, *b*, *c*, and *d*, respectively (bits 127-64 of each XMM register are

undefined and not shown). Argument values e and f are passed on the stack. Note that general-purpose registers RCX, RDX, R8, and R9 are undefined since the function `CalcSum_` does not specify any integer arguments. The code for function `CalcSum_` is straightforward; a series of `addsd` instructions sums up the argument values. The `cvtss2sd` instruction is also employed to promote the single-precision floating-point arguments a, c, and e to double-precision. Since the calculated sum is already in register XMM0, a final `movsd` instruction is not necessary.

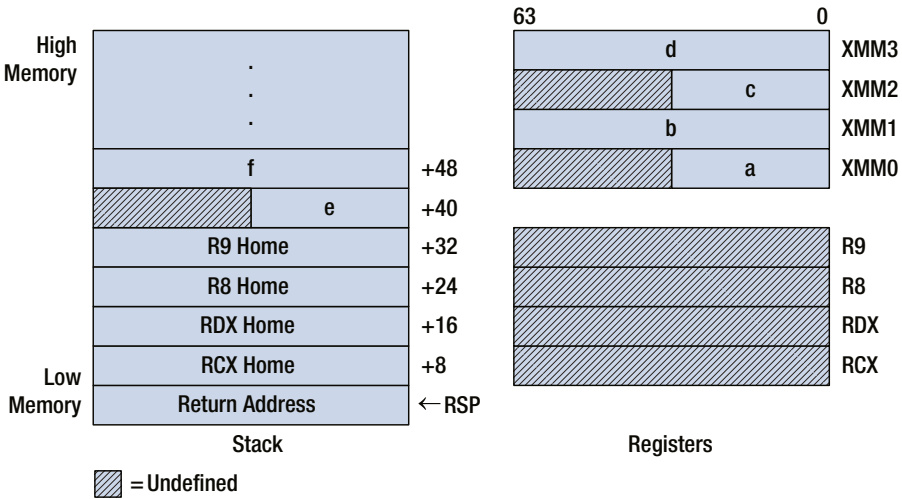

Figure 18-4. Stack layout and register contents at entry to function `CalcSum_`

For functions that include both integer and floating-point arguments, the caller must use either a general-purpose register or an XMM register depending on the argument type and position. If a called function’s first argument is an integer (or pointer) type, the value is passed using register RCX. If the first argument is a floating-point value, register XMM0 must be used. The second function argument must be placed in register RDX or XMM1, depending on whether it’s an integer or floating-point type. The caller must copy the third and fourth arguments to registers R8/XMM2 and R9/XMM3, respectively. Any additional arguments are passed using the stack.

The `CalcDist_` function computes the distance between two points in three-dimensional space. The first four arguments of this function are located in either a general-purpose or XMM register, depending on the argument type. The remaining arguments are passed via the stack, as shown in Figure 18-5. The arithmetic calculations carried out by `CalcDist_` are straightforward. Note that the `cvtss2sd` and `cvtss2sd` instructions are used to convert integer and single-precision floating-point argument values to double-precision floating-point. Output 18-4 shows the results of the sample program `FloatingPointArithmetic`.

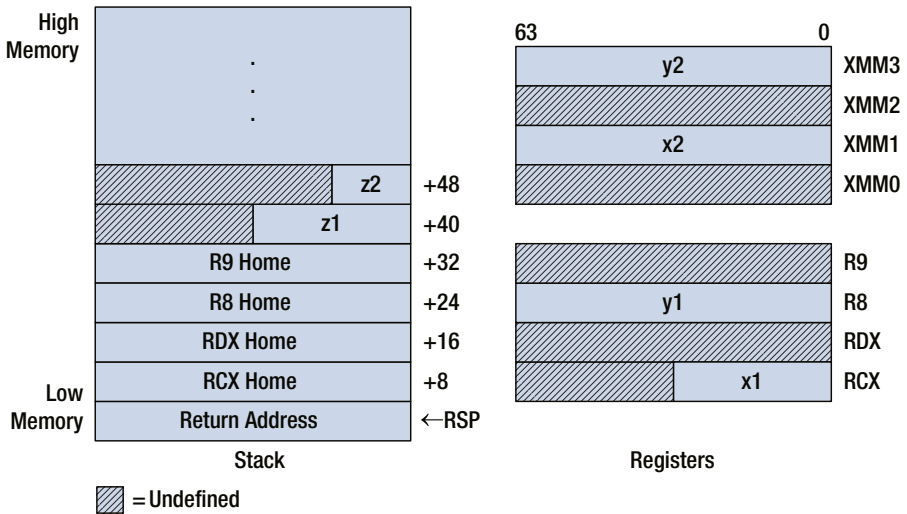

Figure 18-5. Stack layout and register contents at entry to function `CalcDist_`

Output 18-4. Sample Program FloatingPointArithmetic

Results for `CalcSum()`

a: 10.0000 b: 20.0000 c: 0.5000
d: 0.0625 e: 15.0000 f: 0.1250

sum: 45.6875

Results for `CalcDist()`

x1: 5 x2: 12.8750
y1: 17 y2: 23.1875
z1: -2.0625 z2: -6

dist: 10.761259

X86-64 Calling Convention

In this section, you learn how to code an x86-64 non-leaf function. As mentioned earlier in this chapter, the Visual C++ calling convention imposes some strict programming requirements for prologs and epilogs in non-leaf functions. The calling convention also mandates the use of additional assembler directives, which are used by the assembler to generate static data that the Visual C++ run-time environment needs to process exceptions. The benefits of creating non-leaf functions include complete use of all general-purpose and XMM registers, stack frame pointers, local stack variables, and the ability to call other functions.

The first three sample programs in this section illustrate how to code x86-64 non-leaf functions using explicit instructions and assembler directives. They also convey critical programming information regarding the organization of a non-leaf function stack. The fourth sample program exemplifies use of several prolog and epilog macros, which can be employed to automate most of the programming labor that's associated with non-leaf functions.

Basic Stack Frames

The first sample program in this section is named `CallingConvention1`. This program demonstrates how to initialize a stack frame pointer in an x86-64 assembly language function, which can be used to reference argument values and local variables on the stack. It also illustrates some of the programming protocols that an x86-64 assembly language function prolog and epilog must observe. Listings 18-9 and 18-10 show the C++ and assembly language source code for `CallingConvention1`.

Listing 18-9. `CallingConvention1.cpp`

```
#include "stdafx.h"
#include "MiscDefs.h"

extern "C" Int64 Cc1_(Int8 a, Int16 b, Int32 c, Int64 d, Int8 e, Int16 f,
Int32 g, Int64 h);

int _tmain(int argc, _TCHAR* argv[])
{
    Int8 a = 10, e = -20;
    Int16 b = -200, f = 400;
    Int32 c = 300, g = -600;
    Int64 d = 4000, h = -8000;

    Int64 x = Cc1_(a, b, c, d, e, f, g, h);

    printf("\nResults for CallingConvention1\n");
    printf("  a, b, c, d: %8d %8d %8d %8lld\n", a, b, c, d);
    printf("  e, f, g, h: %8d %8d %8d %8lld\n", e, f, g, h);
    printf("  x:           %8lld\n", x);
    return 0;
}
```

Listing 18-10. CallingConvention1.asm

```

.code

; extern "C" Int64 Cc1_(Int8 a, Int16 b, Int32 c, Int64 d, Int8 e, Int16 f,
Int32 g, Int64 h);
;
; Description: The following function illustrates how to create and
; use a basic x86-64 stack frame pointer.

Cc1_ proc frame

; Function prolog
    push rbp                ;save caller's rbp register
    .pushreg rbp

    sub rsp,16             ;allocate local stack space
    .allocstack 16

    mov rbp,rsp           ;set frame pointer
    .setframe rbp,0

RBP_RA = 24                ;offset from rbp to ret addr
    .endprolog            ;mark end of prolog

; Save argument registers to home area (optional)
    mov [rbp+RBP_RA+8],rcx
    mov [rbp+RBP_RA+16],rdx
    mov [rbp+RBP_RA+24],r8
    mov [rbp+RBP_RA+32],r9

; Sum the argument values a, b, c, and d
    movsx rcx,c1           ;rcx = a
    movsx rdx,dx          ;rdx = b
    movsxd r8,r8d         ;r8 = c;
    add rcx,rdx           ;rcx = a + b
    add r8,r9             ;r8 = c + d
    add r8,rcx            ;r8 = a + b + c + d
    mov [rbp],r8         ;save a + b + c + d

; Sum the argument values e, f, g, and h
    movsx rcx,byte ptr [rbp+RBP_RA+40] ;rcx = e
    movsx rdx,word ptr [rbp+RBP_RA+48] ;rdx = f
    movsxd r8,dword ptr [rbp+RBP_RA+56] ;r8 = g
    add rcx,rdx           ;rcx = e + f
    add r8,qword ptr [rbp+RBP_RA+64] ;r8 = g + h
    add r8,rcx            ;r8 = e + f + g + h

```

```

; Compute the final sum
    mov rax,[rbp]           ;rax = a + b + c + d
    add rax,r8              ;rax = final sum

; Function epilog
    add rsp,16              ;release local stack space
    pop rbp                 ;restore caller's rbp register
    ret

Cc1_  endp
      end

```

The purpose of the code in the `CallingConvention1.cpp` file (see Listing 18-9) is to initialize a test case for the assembly language function `Cc1_`. This function calculates and returns the sum of its eight signed-integer argument values. The results are then displayed using a series of calls to `printf`.

The `Cc1_` function is located in the `CallingConvention1.asm` file (see Listing 18-10). Following the `.code` directive is the `Cc1_ proc` `fame` statement. The `proc` statement marks the beginning of the function's prolog and the frame attribute notifies the assembler that the function `Cc1_` uses a stack frame pointer. It also instructs the assembler to generate static table data that the Visual C++ run-time environment uses to process exceptions. The ensuing `push rbp` instruction saves the caller's RBP register on the stack since the `Cc1_` function uses this register as its stack frame pointer. The `.pushreg rbp` statement that follows is an assembler directive that saves offset information about the `push rbp` instruction in the exception handling tables. Keep in mind that assembler directives are not executable instructions; they are directions to the assembler on how to perform specific actions during assembly of the source code.

A `sub rsp,16` instruction allocates 16 bytes of stack space for local variables. The `Cc1_` function only uses eight bytes of this space, but the x86-64 calling convention requires non-leaf functions to maintain 16-byte alignment of the stack pointer outside of the prolog. You learn more about stack pointer alignment requirements later in this section. The next statement, `.allocstack 16`, is an assembler directive that saves local stack size allocation information in the run-time exception handling tables.

The `mov rbp,rsp` instruction initializes register RBP as the stack frame pointer, and the `.setframe rbp,0` directive notifies the assembler of this action. The offset value 0 that's included in the `.setframe` directive is the difference in bytes between RSP and RBP. In function `Cc1_`, registers RSP and RBP are the same so the offset value is zero. Later in this section, you learn more about the `.setframe` directive. It should be noted that x86-64 assembly language functions can use any non-volatile register as a stack frame pointer. Using RBP provides consistency between x86-32 and x86-64 functions. The final assembler directive, `.endprolog`, signifies the end of the prolog for function `Cc1_`. Figure 18-6 shows the stack layout and argument registers following completion of the prolog.

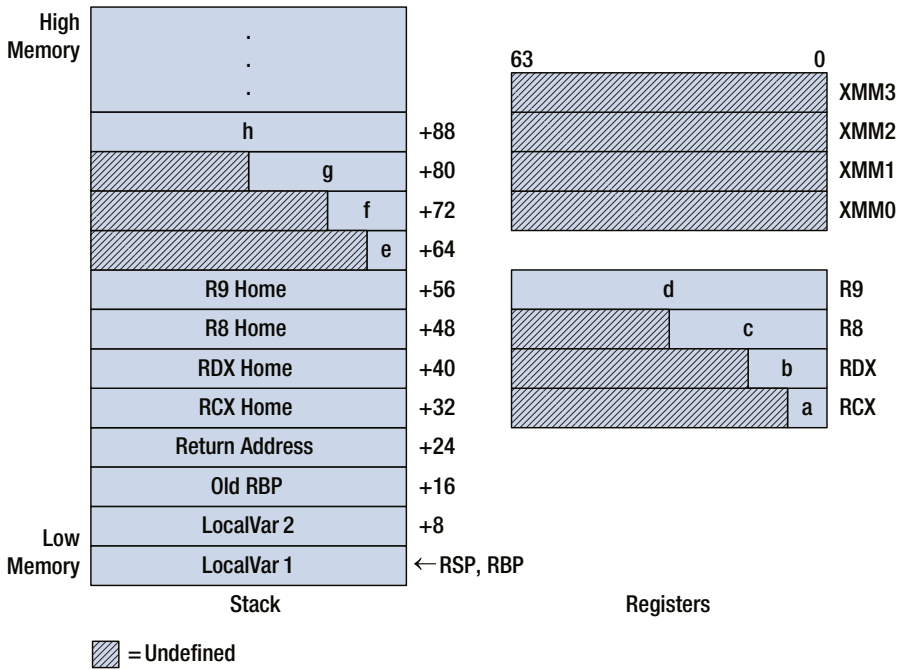

Figure 18-6. Stack layout and register contents at the end of the prolog for function `Cc1_`

The next block of instructions saves registers RCX, RDX, R8, and R9 to their respective home areas on this stack. This action is optional and included in `Cc1_` for illustrative purposes. Note that the offset of each `mov` instruction includes the `RBP_RA` symbol, which equals 24 and represents the extra offset bytes (compared to a standard leaf function) needed to correctly reference the home area of `Cc1_`. Another option allowed by the Visual C++ calling convention is to save an argument register to its corresponding home area prior to the `push rbp` instruction using RSP as a base register (e.g., `mov [rsp+8], rcx`, `mov [rsp+16], rdx`, and so on). Also keep in mind that a function can use its home area to store other temporary values. When used for alternative storage purposes, the home area should not be referenced by an assembly language instruction until after the `.endprolog` directive.

Following the argument register save operation, the function `Cc1_` sums argument values a, b, c, and d. It then saves this intermediate sum to `LocalVar1` on the stack using a `mov [rbp], r8` instruction. Note that the summation calculation sign-extends argument values a, b, and c using a `movsx` or `movsxd` instruction. A similar sequence of instructions is used to sum argument values e, f, g, and h, which are located on the stack and referenced using the stack frame pointer RBP and a constant offset. The `RBP_RA` symbol is also used here to account for the extra stack space needed to reference argument values on the stack. The two intermediate sums are then added to produce the final result in register RAX.

An x86-64 function epilog must release any local stack storage space that was allocated in the prolog, restore any non-volatile registers that were saved on the stack, and execute a function return. The `add rsp, 16` instruction releases the 16 bytes of stack space that `Cc1_` allocated in its prolog. This is followed by a `pop rbp` instruction, which restores the caller's RBP register. The obligatory `ret` instruction is next. Output 18-5 shows the results of the sample program `CallingConvention1`.

Output 18-5. Sample Program `CallingConvention1`

Results for `CallingConvention1`

a, b, c, d:	10	-200	300	4000
e, f, g, h:	-20	400	-600	-8000
x:	-4110			

Using Non-Volatile Registers

The next sample program, which is named `CallingConvention2`, demonstrates how to use the non-volatile general-purpose registers in an x86-64 function. It also provides additional programming details regarding the stack frame and use of local variables. The C++ and assembly language source code for sample program `CallingConvention2` are shown in Listings 18-11 and 18-12.

Listing 18-11. `CallingConvention2.cpp`

```
#include "stdafx.h"
#include "MiscDefs.h"

extern "C" bool Cc2_(const Int64* a, const Int64* b, Int32 n, Int64 * sum_a,
Int64* sum_b, Int64* prod_a, Int64* prod_b);

int _tmain(int argc, _TCHAR* argv[])
{
    const __int32 n = 6;
    Int64 a[n] = { 2, -2, -6, 7, 12, 5 };
    Int64 b[n] = { 3, 5, -7, 8, 4, 9 };
    Int64 sum_a, sum_b;
    Int64 prod_a, prod_b;

    printf("\nResults for CallingConvention2\n");
    bool rc = Cc2_(a, b, n, &sum_a, &sum_b, &prod_a, &prod_b);

    if (!rc)
        printf("Invalid return code from Cc2_()\n");
    else
    {
        for (int i = 0; i < n; i++)
            printf("%7lld %7lld\n", a[i], b[i]);
    }
}
```

```

    printf("\n");
    printf("sum_a: %7lld sum_b: %7lld\n", sum_a, sum_b);
    printf("prod_a: %7lld prod_b: %7lld\n", prod_a, prod_b);
}

return 0;
}

```

Listing 18-12. CallingConvention2.asm

```

.code

; extern "C" void Cc2_(const Int64* a, const Int64* b, Int32 n, Int64*
sum_a, Int64* sum_b, Int64* prod_a, Int64* prod_b);
;
; Description: The following function illustrates how to initialize and
; use a stack frame pointer. It also demonstrates use
; of several non-volatile general-purpose registers.

; Named expressions for constant values.
;
; NUM_PUSHREG = number of prolog non-volatile register pushes
; STK_LOCAL1 = size in bytes of STK_LOCAL1 area (see figure in text)
; STK_LOCAL2 = size in bytes of STK_LOCAL2 area (see figure in text)
; STK_PAD = extra bytes (0 or 8) needed to 16-byte align RSP
; STK_TOTAL = total size in bytes of local stack
; RBP_RA = number of bytes between RBP and ret addr on stack

NUM_PUSHREG = 4
STK_LOCAL1 = 32
STK_LOCAL2 = 16
STK_PAD = ((NUM_PUSHREG AND 1) XOR 1) * 8
STK_TOTAL = STK_LOCAL1 + STK_LOCAL2 + STK_PAD
RBP_RA = NUM_PUSHREG * 8 + STK_LOCAL1 + STK_PAD

Cc2_ proc frame

; Save non-volatile registers on the stack
push rbp
.pushreg rbp
push rbx
.pushreg rbx
push r12
.pushreg r12
push r13
.pushreg r13

```

```

; Allocate local stack space and set frame pointer
    sub rsp,STK_TOTAL           ;allocate local stack space
    .allocstack STK_TOTAL

    lea rbp,[rsp+STK_LOCAL2]    ;set frame pointer
    .setframe rbp,STK_LOCAL2

    .endprolog                 ;end of prolog

; Initialize local variables on the stack (demonstration only)
    pxor xmm5,xmm5
    movdq [rbp-16],xmm5         ;save xmm5 to LocalVar2A/2B
    mov qword ptr [rbp],0aah    ;save 0xaa to LocalVar1A
    mov qword ptr [rbp+8],0bbh  ;save 0xbb to LocalVar1B
    mov qword ptr [rbp+16],0cch ;save 0xcc to LocalVar1C
    mov qword ptr [rbp+24],0ddh ;save 0xdd to LocalVar1D

; Save argument values to home area (optional)
    mov qword ptr [rbp+RBP_RA+8],rcx
    mov qword ptr [rbp+RBP_RA+16],rdx
    mov qword ptr [rbp+RBP_RA+24],r8
    mov qword ptr [rbp+RBP_RA+32],r9

; Perform required initializations for processing loop
    test r8d,r8d                ;is n <= 0?
    jle Error                    ;jump if n <= 0

    xor rbx,rbx                 ;rbx = current element offset
    xor r10,r10                 ;r10 = sum_a
    xor r11,r11                 ;r11 = sum_b
    mov r12,1                   ;r12 = prod_a
    mov r13,1                   ;r13 = prod_b

; Compute the array sums and products
@@:    mov rax,[rcx+rbx]         ;rax = a[i]
    add r10,rax                 ;update sum_a
    imul r12,rax                ;update prod_a
    mov rax,[rdx+rbx]         ;rax = b[i]
    add r11,rax                 ;update sum_b
    imul r13,rax               ;update prod_b

    add rbx,8                   ;set ebx to next element
    dec r8d                     ;adjust count
    jnz @@                      ;repeat until done

; Save the final results
    mov [r9],r10                ;save sum_a
    mov rax,[rbp+RBP_RA+40]    ;rax = ptr to sum_b

```



```

    mov [rax],r11                ;save sum_b
    mov rax,[rbp+RBP_RA+48]     ;rax = ptr to prod_a
    mov [rax],r12                ;save prod_a
    mov rax,[rbp+RBP_RA+56]     ;rax = ptr to prod_b
    mov [rax],r13                ;save prod_b
    mov eax,1                    ;set return code to true

; Function epilog
Done:  lea rsp,[rbp+STK_LOCAL1+STK_PAD] ;restore rsp
      pop r13                       ;restore NV registers
      pop r12
      pop rbx
      pop rbp
      ret

Error: xor eax,eax                ;set return code to false
      jmp Done

Cc2_  endp
      end

```

The purpose of the code C++ in the `CallingConvention2.cpp` file (see Listing 18-11) is to set up a simple test case in order to exercise the assembly language function `Cc2_`. In this sample program, the function `Cc2_` calculates the sums and products of two 64-bit signed integer arrays. The results are then displayed using a series of `printf` statements.

Toward the top of the assembly language file `CallingConvention2.asm` (see Listing 18-12) is a series of named constants that control how much stack space is allocated in the prolog of function `Cc2_`. Like the previous sample program, the function `Cc2_` includes the frame attribute as part of its `proc` statement to indicate that it uses a stack frame pointer. A series of push instructions saves non-volatile registers `RBP`, `RBX`, `R12`, and `R13` on the stack. Note that a `.pushreg` directive is used following each push instruction, which instructs the assembler to add information about each push operation to the Visual C++ run-time exception handling tables.

A `sub rsp,STK_TOTAL` instruction allocates space on the stack for local variables, and the required `.allocstack STK_TOTAL` directive follows next. Register `RBP` is then initialized as the function's stack frame pointer using an `lea rbp,[rsp+STK_LOCAL2]` instruction, which sets `RBP` equal to `rsp + STK_LOCAL2`. Figure 18-7 illustrates the layout of the stack following execution of the `lea` instruction. Positioning `RBP` so that it "splits" the local stack area into two sections enables the assembler to generate machine code that's slightly more efficient since a larger portion of the local stack area can be referenced using 8-bit instead of 32-bit displacements. It also simplifies saving and restoring of the non-volatile XMM registers, which is discussed later in this section. Following the `lea` instruction is a `.setframe rbp,STK_LOCAL2` directive that enables the assembler to properly configure the run-time exception handling tables. Note that the size parameter of this directive must be an even multiple of 16 and less than or equal to 240. The `.endprolog` directive signifies the end of the prolog for function `Cc2_`.

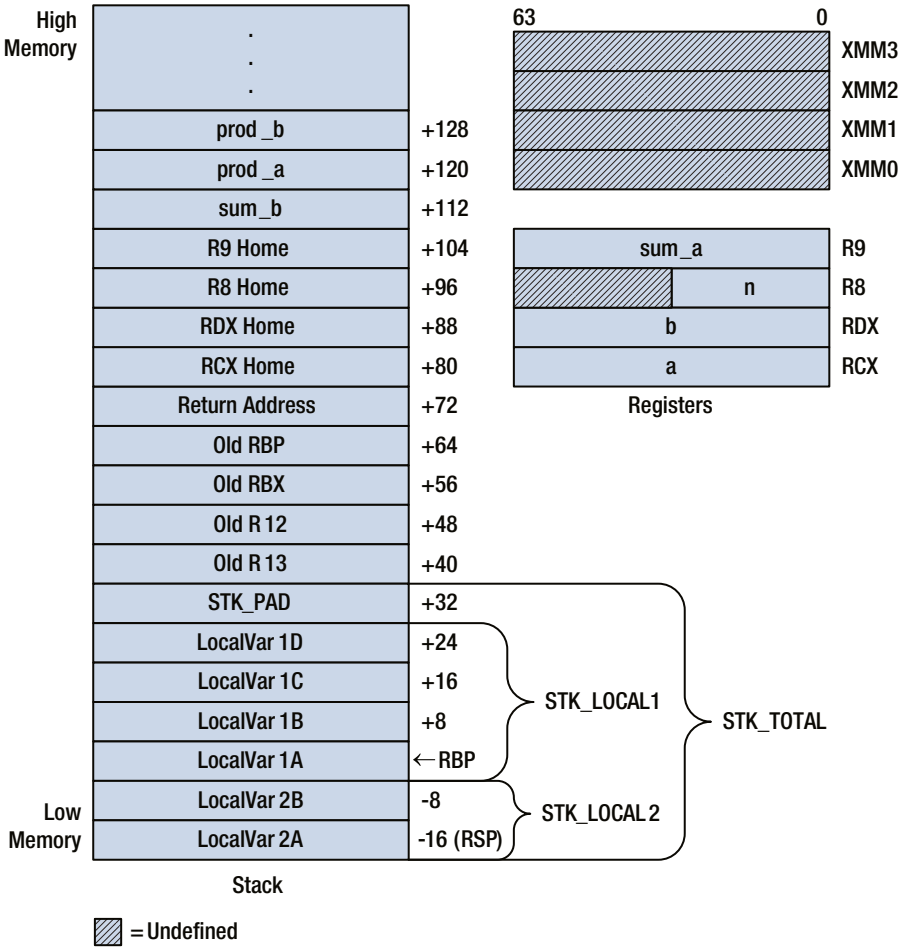

Figure 18-7. Stack layout and register contents following execution of the `lea rbp, [rsp+STK_LOCAL2]` instruction in function `Cc2_`

The next code block contains instructions that initialize the local variables on the stack. These instructions are for demonstration purposes only. Note that this block includes a `movdqa [rbp-16], xmm5` instruction, which requires its destination operand to be aligned on a 16-byte boundary. This is another reason why the calling convention mandates 16-byte alignment of the RSP register. Following initialization of the local variables, the argument registers are saved to their home locations, also for demonstration purposes.

The logic of the main processing loop is straightforward. Following validation of argument value `n`, the function `Cc2_` initializes the intermediate values `sum_a` (R10) and `sum_b` (R11) to zero and `prod_a` (R12) and `prod_b` (R13) to one. It then calculates the sum and product of the input arrays `a` and `b`. The final results are saved to the memory locations specified by the caller. Note that the pointers for `sum_b`, `prod_a`, and `prod_b` are located on the stack.

The function's epilog begins with a `lea rsp, [rbp+STK_LOCAL1+STK_PAD]` instruction, which restores register RSP to the value it had just after the `push r13` instruction in the prolog. When restoring RSP in an epilog, the Visual C++ calling convention specifies that either a `lea rsp, [rfp+X]` or `add rsp, X` instruction must be used, where `rfp` denotes the frame pointer register and `X` is a constant value. This limits the number of instruction patterns that the run-time exception handler must identify. The subsequent `pop` instructions restore the non-volatile general-purpose registers prior to execution of the `ret` instruction. According to the Visual C++ calling convention, function epilogs must be void of any processing logic, including the setting of a return value. Output 18-6 shows the results of the sample program `CallingConvention2`.

Output 18-6. Sample Program `CallingConvention2`

Results for `CallingConvention2`

```

  2      3
 -2      5
 -6     -7
  7      8
 12     4
  5      9

```

```

sum_a:      18 sum_b:      22
prod_a:   10080 prod_b:  -30240

```

Using Non-Volatile XMM Registers

Earlier in this chapter, you learned how to use the volatile XMM registers to perform scalar floating-point arithmetic. The sample program in this section, which is named `CallingConvention3`, illustrates the prolog and epilog conventions that must be observed in order to use the non-volatile XMM registers. The C++ and assembly language source code for sample program `CallingConvention3` are shown in Listings 18-13 and 18-14.

Listing 18-13. `CallingConvention3.cpp`

```

#include "stdafx.h"
#define _USE_MATH_DEFINES
#include <math.h>

extern "C" void Cc3_(const double* r, const double* h, int n, double* sa_cone, double* vol_cone);

int _tmain(int argc, _TCHAR* argv[])
{
    const int n = 6;
    double r[n] = { 1, 1, 2, 2, 3, 3 };
    double h[n] = { 1, 2, 3, 4, 5, 10 };
    double sa_cone1[n], sa_cone2[n];
    double vol_cone1[n], vol_cone2[n];

```

```

// Calculate surface area and volume of right-circular cones
for (int i = 0; i < n; i++)
{
    sa_cone1[i] = M_PI * r[i] * (r[i] + sqrt(r[i] * r[i] + h[i] * h[i]));
    vol_cone1[i] = M_PI * r[i] * r[i] * h[i] / 3.0;
}

Cc3_(r, h, n, sa_cone2, vol_cone2);

printf("\nResults for CallingConvention3\n");
for (int i = 0; i < n; i++)
{
    printf("  r/h: %14.2lf %14.2lf\n", r[i], h[i]);
    printf("  sa:  %14.6lf %14.6lf\n", sa_cone1[i], sa_cone2[i]);
    printf("  vol: %14.6lf %14.6lf\n", vol_cone1[i], vol_cone2[i]);
    printf("\n");
}

return 0;
}

```

Listing 18-14. CallingConvention4.asm

```

        .const
r8_3p0   real8 3.0
r8_pi    real8 3.14159265358979323846
        .code

; extern "C" bool Cc3_(const double* r, const double* h, int n, double*
sa_cone, double* vol_cone);
;
; Description: The following function illustrates how to initialize and
;               use a stack frame pointer. It also demonstrates use
;               of non-volatile general-purpose and XMM registers.

; Named expressions for constant values.
;
; NUM_PUSHREG   = number of prolog non-volatile register pushes
; STK_LOCAL1    = size in bytes of STK_LOCAL1 area (see figure in text)
; STK_LOCAL2    = size in bytes of STK_LOCAL2 area (see figure in text)
; STK_PAD       = extra bytes (0 or 8) needed to 16-byte align RSP
; STK_TOTAL     = total size in bytes of local stack
; RBP_RA        = number of bytes between RBP and ret addr on stack

NUM_PUSHREG   = 7
STK_LOCAL1    = 16
STK_LOCAL2    = 64

```

```

STK_PAD      = ((NUM_PUSHREG AND 1) XOR 1) * 8
STK_TOTAL   = STK_LOCAL1 + STK_LOCAL2 + STK_PAD
RBP_RA      = NUM_PUSHREG * 8 + STK_LOCAL1 + STK_PAD

```

```
Cc3_  proc frame
```

```
; Save non-volatile registers on the stack.
```

```

push rbp
.pushreg rbp
push rbx
.pushreg rbx
push rsi
.pushreg rsi
push r12
.pushreg r12
push r13
.pushreg r13
push r14
.pushreg r14
push r15
.pushreg r15

```

```
; Allocate local stack space and initialize frame pointer
```

```

sub rsp,STK_TOTAL           ;allocate local stack space
.allocstack STK_TOTAL
lea rbp,[rsp+STK_LOCAL2]   ;rbp = stack frame pointer
.setframe rbp,STK_LOCAL2

```

```
; Save non-volatile registers XMM12 - XMM15. Note that STK_LOCAL2 must
; be greater than or equal to the number of XMM register saves times 16.
```

```

movdqa xmmword ptr [rbp-STK_LOCAL2+48],xmm12
.savexmm128 xmm12,48
movdqa xmmword ptr [rbp-STK_LOCAL2+32],xmm13
.savexmm128 xmm13,32
movdqa xmmword ptr [rbp-STK_LOCAL2+16],xmm14
.savexmm128 xmm14,16
movdqa xmmword ptr [rbp-STK_LOCAL2],xmm15
.savexmm128 xmm15,0
.endprolog

```

```
; Access local variables on the stack (demonstration only)
```

```

mov qword ptr [rbp],-1           ;LocalVar1A = -1
mov qword ptr [rbp+8],-2       ;LocalVar1B = -2

```

```

; Initialize the processing loop variables. Note that many of the
; register initializations below are performed merely to illustrate
; use of the non-volatile GP and XMM registers.
    movsxd rsi,r8d                ;rsi = n
    test rsi,rsi                 ;is n <= 0?
    jle Error                    ;jump if n <= 0

    xor rbx,rbx                  ;rbx = array element offset
    mov r12,rcx                  ;r12 = ptr to r
    mov r13,rdx                  ;r13 = ptr to h
    mov r14,r9                   ;r14 = ptr to sa_cone
    mov r15,[rbp+RBP_RA+40]      ;r15 = ptr to vol_cone
    movsd xmm14,[r8_pi]          ;xmm14 = pi
    movsd xmm15,[r8_3p0]         ;xmm15 = 3.0

; Calculate cone surface areas and volumes
; sa = pi * r * (r + sqrt(r * r + h * h))
; vol = pi * r * r * h / 3
@@:    movsd xmm0,real8 ptr [r12+rbx] ;xmm0 = r
        movsd xmm1,real8 ptr [r13+rbx] ;xmm1 = h
        movsd xmm12,xmm0                ;xmm12 = r
        movsd xmm13,xmm1                ;xmm13 = h

        mulsd xmm0,xmm0                 ;xmm0 = r * r
        mulsd xmm1,xmm1                 ;xmm1 = h * h
        addsd xmm0,xmm1                 ;xmm0 = r * r + h * h

        sqrtsd xmm0,xmm0                ;xmm0 = sqrt(r * r + h * h)
        addsd xmm0,xmm12                ;xmm0 = r + sqrt(r * r + h * h)
        mulsd xmm0,xmm12                ;xmm0 = r * (r + sqrt(r * r + h * h))
        mulsd xmm0,xmm14                ;xmm0 = pi * r * (r + sqrt(r * r + h * h))

        mulsd xmm12,xmm12               ;xmm12 = r * r
        mulsd xmm13,xmm14               ;xmm13 = h * pi
        mulsd xmm13,xmm12               ;xmm13 = pi * r * r * h
        divsd xmm13,xmm15               ;xmm13 = pi * r * r * h / 3

        movsd real8 ptr [r14+rbx],xmm0 ;save surface area
        movsd real8 ptr [r15+rbx],xmm13 ;save volume

        add rbx,8                       ;set rbx to next element
        dec rsi                          ;update counter
        jnz @B                           ;repeat until done
        mov eax,1                        ;set success return code

```

```

; Restore non-volatile XMM registers
Done:  movdqa xmm12,xmmword ptr [rbp-STK_LOCAL2+48]
       movdqa xmm13,xmmword ptr [rbp-STK_LOCAL2+32]
       movdqa xmm14,xmmword ptr [rbp-STK_LOCAL2+16]
       movdqa xmm15,xmmword ptr [rbp-STK_LOCAL2]

; Function epilog
       lea rsp,[rbp+STK_LOCAL1+STK_PAD]    ;restore rsp
       pop r15                             ;restore NV GP registers
       pop r14
       pop r13
       pop r12
       pop rsi
       pop rbx
       pop rbp
       ret

Error: xor eax,eax                          ;set error return code
       jmp Done

Cc3_   endp
       end

```

The `_tmain` function (see Listing 18-13) contains code that calculates the surface area and volume of right-circular cones. It also exercises an x86-64 assembly language function named `Cc3_`, which performs the same surface area and volume calculations. The following formulas are used to calculate a cone's surface area and volume:

$$sa = \pi r \left(r + \sqrt{r^2 + h^2} \right) \quad vol = \pi r^2 h / 3$$

The `Cc3_` function (see Listing 18-14) begins by saving the non-volatile general-purpose registers that it uses on the stack. It then allocates the specified amount of local stack space and initializes RBP as the stack frame pointer. The next code block saves non-volatile registers XMM12-XMM15 on the stack using a series of `movdqa` instructions. A `.savexmm128` directive must be used after each `movdqa` instruction. Like the other `prolog` directives, the `.savexmm128` directive instructs the assembler to store information regarding an XMM register save operation in its exception handling tables. The offset argument of a `.savexmm128` directive represents the displacement of the saved XMM register on the stack relative to the RSP register. Note that the size of `STK_LOCAL2` must be greater than or equal to the number of saved XMM registers multiplied by 16. Figure 18-8 illustrates the layout of the stack following execution of the `movdqa xmmword ptr [rbp-STK_LOCAL2],xmm15` instruction.

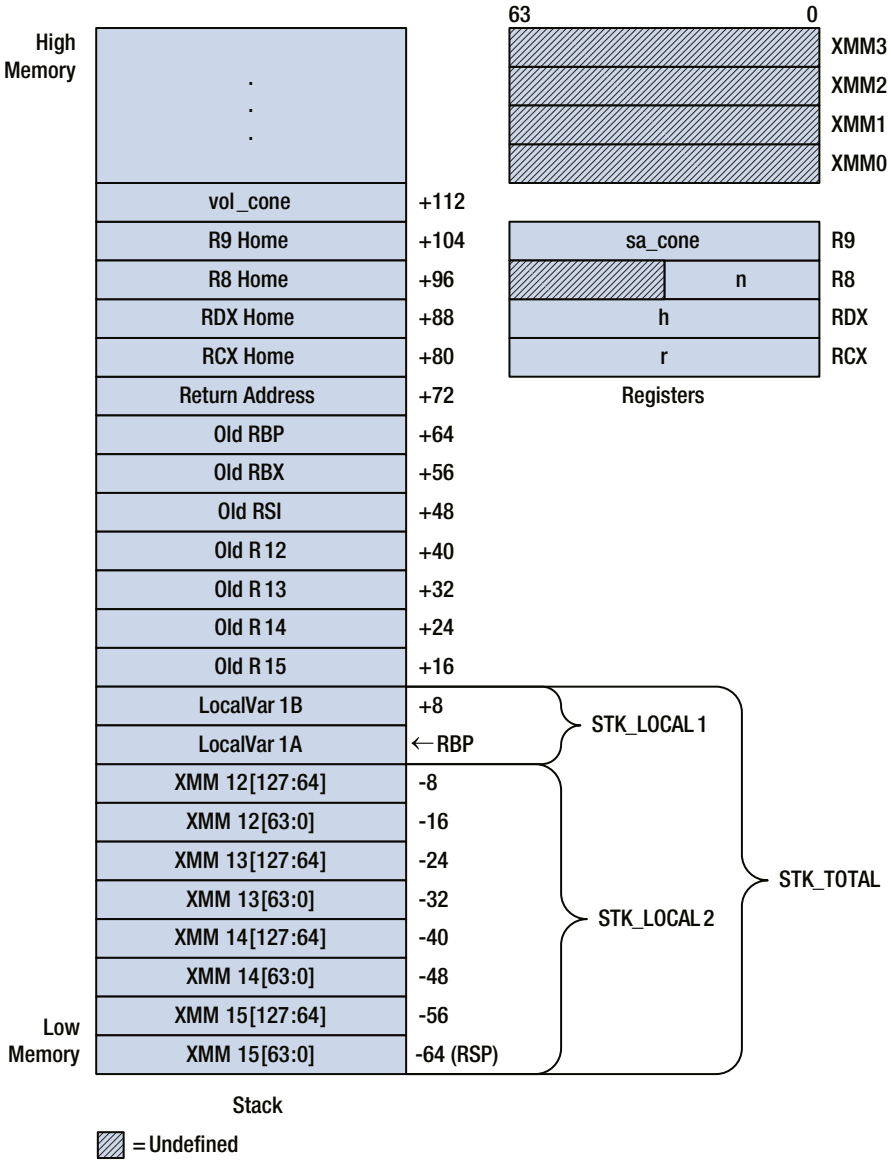

Figure 18-8. Stack layout and register contents following execution of the `movdqa xmmword ptr [rbp-STK_LOCAL2],xmm15` instruction in function `Cc3_`

Following the prolog, the local variables `LocalVar1A` and `LocalVar1B` are accessed for demonstration purposes only. Initialization of the registers used by the main processing loop occurs next. Note that many of these initializations are superfluous; they are performed merely to elucidate use of the non-volatile general-purpose and XMM registers. Calculation of the cone surface areas and volumes is then carried out using SSE2 double-precision floating-point arithmetic.

Subsequent to the completion of the processing loop, the non-volatile XMM registers are restored using a series of `movdqa` instructions. The function `Cc3_` then releases its local stack space and restores the previously saved non-volatile general-purpose registers that it used. The results of the sample program `CallingConvention3` are shown in Output 18-7.

Output 18-7. Sample Program `CallingConvention3`

Results for `CallingConvention3`

r/h:	1.00	1.00
sa:	7.584476	7.584476
vol:	1.047198	1.047198
r/h:	1.00	2.00
sa:	10.166407	10.166407
vol:	2.094395	2.094395
r/h:	2.00	3.00
sa:	35.220717	35.220717
vol:	12.566371	12.566371
r/h:	2.00	4.00
sa:	40.665630	40.665630
vol:	16.755161	16.755161
r/h:	3.00	5.00
sa:	83.229761	83.229761
vol:	47.123890	47.123890
r/h:	3.00	10.00
sa:	126.671905	126.671905
vol:	94.247780	94.247780

Macros for Prologs and Epilogs

The purpose of the previous three sample programs was to elucidate use of the Visual C++ calling convention for 64-bit non-leaf functions. The calling convention's rigid requirements for function prologs and epilogs are somewhat lengthy and a potential source of programming errors. It is important to recognize that the stack layout of a 64-bit non-leaf function is primarily determined by the number of non-volatile

(both general-purpose and XMM) registers that must be preserved and the amount of local stack storage space that's needed. A method is needed to automate most of the coding drudgery associated with the calling convention.

The sample program in this section exemplifies the use of several macros that the author has written to simplify stack frame creation and preservation of non-volatile registers in a 64-bit non-leaf function. Listings 18-15 and 18-16 contain the C++ and assembly language source code for sample program CallingConvention4.

Listing 18-15. CallingConvention4.cpp

```
#include "stdafx.h"
#include <math.h>

extern "C" bool Cc4(const double* ht, const double* wt, int n, double*
bsa1, double* bsa2, double* bsa3);

int _tmain(int argc, _TCHAR* argv[])
{
    const int n = 6;
    const double ht[n] = { 150, 160, 170, 180, 190, 200 };
    const double wt[n] = { 50.0, 60.0, 70.0, 80.0, 90.0, 100.0 };
    double bsa1_a[n], bsa1_b[n];
    double bsa2_a[n], bsa2_b[n];
    double bsa3_a[n], bsa3_b[n];

    for (int i = 0; i < n; i++)
    {
        bsa1_a[i] = 0.007184 * pow(ht[i], 0.725) * pow(wt[i], 0.425);
        bsa2_a[i] = 0.0235 * pow(ht[i], 0.42246) * pow(wt[i], 0.51456);
        bsa3_a[i] = sqrt(ht[i] * wt[i]) / 60.0;
    }

    Cc4(ht, wt, n, bsa1_b, bsa2_b, bsa3_b);

    printf("Results for CallingConvention4\n\n");

    for (int i = 0; i < n; i++)
    {
        printf("height: %6.1lf cm\n", ht[i]);
        printf("weight: %6.1lf kg\n", wt[i]);
        printf("BSA (C++): %10.6lf %10.6lf %10.6lf (sq. m)\n", bsa1_a[i],
bsa2_a[i], bsa3_a[i]);
        printf("BSA (X86-64): %10.6lf %10.6lf %10.6lf (sq. m)\n", bsa1_b[i],
bsa2_b[i], bsa3_b[i]);
        printf("\n");
    }
    return 0;
}
```

Listing 18-16. CallingConvention4_.asm

```

include <MacrosX86-64.inc>

; Floating-point constants for BSA equations
        .const
r8_0p007184    real8 0.007184
r8_0p725      real8 0.725
r8_0p425      real8 0.425
r8_0p0235     real8 0.0235
r8_0p42246    real8 0.42246
r8_0p51456    real8 0.51456
r8_60p0       real8 60.0

        .code
extern pow:proc

; extern "C" bool Cc4_(const double* ht, const double* wt, int n, double*
bsa1, double* bsa2, double* bsa3);
;
; Description: The following function demonstrates use of the macros
;              _CreateFrame, _DeleteFrame, _EndProlog, _SaveXmmRegs,
;              and _RestoreXmmRegs.

Cc4_    proc frame
        _CreateFrame Cc4_,16,64,rbx,rsi,r12,r13,r14,r15
        _SaveXmmRegs xmm6,xmm7,xmm8,xmm9
        _EndProlog

; Save argument registers to home area (optional). Note that the home
; area can also be used to store other transient data values.
        mov qword ptr [rbp+Cc4_OffsetHomeRCX],rcx
        mov qword ptr [rbp+Cc4_OffsetHomeRDX],rdx
        mov qword ptr [rbp+Cc4_OffsetHomeR8],r8
        mov qword ptr [rbp+Cc4_OffsetHomeR9],r9

; Initialize processing loop pointers. Note that the pointers are
; maintained in non-volatile registers, which eliminates reloads
; after calls to pow().
        test r8d,r8d                ;is n <= 0?
        jle Error                    ;jump if n <= 0
        mov [rbp],r8d                ;save n to local var

        mov r12,rcx                  ;r12 = ptr to ht
        mov r13,rdx                  ;r13 = ptr to wt
        mov r14,r9                   ;r14 = ptr to bsa1
        mov r15,[rbp+Cc4_OffsetStackArgs] ;r15 = ptr to bsa2
        mov rbx,[rbp+Cc4_OffsetStackArgs+8] ;rbx = ptr to bsa3
        xor rsi,rsi                  ;array element offset

```

```

; Allocate home space on stack for use by pow()
    sub rsp,32

; Calculate bsa1 = 0.007184 * pow(ht, 0.725) * pow(wt, 0.425);
@@:  movsd xmm0,real8 ptr [r12+rsi]      ;xmm0 = height
     movsd xmm8,xmm0
     movsd xmm1,real8 ptr [r8_0p725]
     call pow                          ;xmm0 = pow(ht,0.725)
     movsd xmm6,xmm0

     movsd xmm0,real8 ptr [r13+rsi]    ;xmm0 = weight
     movsd xmm9,xmm0
     movsd xmm1,real8 ptr [r8_0p425]
     call pow                          ;xmm0 = pow(wt,0.425)
     mulsd xmm6,real8 ptr [r8_0p007184]
     mulsd xmm6,xmm0                  ;xmm6 = bsa1

; Calculate bsa2 = 0.0235 * pow(ht, 0.42246) * pow(wt, 0.51456);
     movsd xmm0,xmm8                  ;xmm0 = height
     movsd xmm1,real8 ptr [r8_0p42246]
     call pow                          ;xmm0 = pow(ht,0.42246)
     movsd xmm7,xmm0

     movsd xmm0,xmm9                  ;xmm0 = weight
     movsd xmm1,real8 ptr [r8_0p51456]
     call pow                          ;xmm0 = pow(wt,0.51456)
     mulsd xmm7,real8 ptr [r8_0p0235]
     mulsd xmm7,xmm0                  ;xmm7 = bsa2

; Calculate bsa3 = sqrt(ht * wt) / 60.0;
     mulsd xmm8,xmm9
     sqrtsd xmm8,xmm8
     divsd xmm8,real8 ptr [r8_60p0]    ;xmm8 = bsa3

; Save BSA results
     movsd real8 ptr [r14+rsi],xmm6    ;save bsa1 result
     movsd real8 ptr [r15+rsi],xmm7    ;save bsa2 result
     movsd real8 ptr [rbx+rsi],xmm8    ;save bsa3 result

     add rsi,8                          ;update array offset
     dec dword ptr [rbp]                ;n = n - 1
     jnz @B
     mov eax,1                          ;set success return code

; Restore all used non-volatile XMM and GP registers. Note that the
; _DeleteFrame macro restores rsp from rbp, which means that it is not
; necessary to include an explicit add rsp,32 instruction to "free"

```

```

; the pow() home area.
Done:  _RestoreXmmRegs xmm6,xmm7,xmm8,xmm9
      _DeleteFrame rbx,rsi,r12,r13,r14,r15
      ret

Error: xor eax,eax                                ;set error return code
      jmp Done
Cc4_   endp
      end

```

Similar to the previous sample programs in this section, the primary goal of the code in `_tmain` (see Listing 18-15) is to exercise x86-64 assembly language function `Cc4_`. This function calculates estimates of human body surface areas (BSA) using several well-known equations, which are defined in Table 18-2. Each equation in this table uses the symbol H for height in centimeters, W for weight in kilograms, and BSA for body surface area in square meters.

Table 18-2. *Body Surface Area Equations*

Formula	Equation
DuBois and DuBois	$BSA = 0.007184 \times H^{0.725} \times W^{0.425}$
Gehan and George	$BSA = 0.0235 \times H^{0.42246} \times W^{0.51456}$
Mosteller	$BSA = \sqrt{H \times W} / 3600$

The assembly language file `CallingConvention4_.asm` (see Listing 18-16) begins with an `include` statement that incorporates the contents of the `MacrosX86-64.inc` file (source code not shown). This file, which is located in a subfolder named `CommonFiles`, contains the macro definitions that are used by the sample program `CallingConvention4`. These macros are also used in subsequent sample programs. Following the `include` statement is a `.const` section that contains definitions for the various floating-point constant values used in the BSA equations.

Figure 18-9 contains a generic stack layout diagram of an x86-64 non-leaf function. Note the similarities between this figure and the more detailed stack layouts of Figures 18-7 and 18-8. The macros that are defined in the file `MacrosX86-64.inc` assume that a function's basic stack layout will conform to what's shown in Figure 18-9. They enable a function to tailor its own detailed stack frame by specifying the amount of local stack space that's needed and which non-volatile registers must be preserved. The macros also perform most of the required stack offset calculations, which reduces the risk of a programming error in the prolog or epilog.

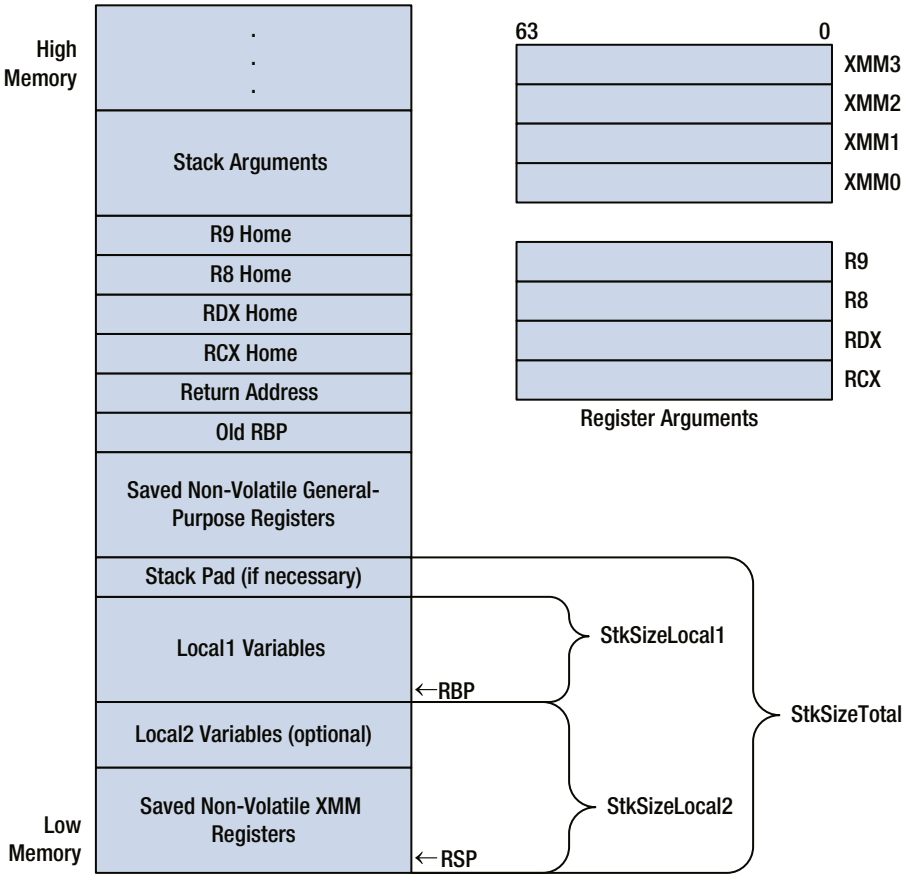

Figure 18-9. Generic stack layout of an x86-64 non-leaf function

Following the `Cc4_proc` frame statement, the macro `_CreateFrame` is used to generate the code that initializes the function's stack frame. It also saves the specified non-volatile general-purpose registers on the stack. The macro requires a number of additional parameters, including a prefix string and the size in bytes of `StkSizeLocal1` and `StkSizeLocal2` (see Figure 18-9). The macro `_CreateFrame` uses the specified prefix string to create symbolic names that can be used to reference items on the stack. It's somewhat convenient to use the name of the function as the prefix string but any unique text string can be used. Both `StkSizeLocal1` and `StkSizeLocal2` must be evenly divisible by 16. `StkSizeLocal2` must also be less than or equal to 240, and greater than or equal to the number of saved XMM registers multiplied by 16.

The next statement employs the `_SaveXmmRegs` macro to save the specified non-volatile XMM registers to the XMM save area on the stack. This is followed by the `_EndProlog` macro, which signifies the end of the function's prolog. Subsequent to the completion of the prolog, register `RBP` is configured as the function's stack frame pointer.

It is also safe to use any of the saved non-volatile general-purpose or XMM registers subsequent to the `_EndProlog` macro.

The block of instructions that follows `_EndProlog` saves the argument registers to their home locations on the stack. Note that each `mov` instruction includes a symbolic name that equates to the offset of the register's home area on the stack relative to the RBP register. The symbolic names and the corresponding offset values were automatically generated by the `_CreateFrame` macro. The home area can also be used to store temporary data instead of the argument registers, as mentioned earlier in this chapter.

Initialization of the processing loop variables occurs next. The value `n` in register `R8D` is checked for validity and saved on the stack as a local variable. Several non-volatile registers are then initialized as pointer registers. Non-volatile registers are used in order to avoid register reloads following each call to the library function `pow`. Note that the pointer to array `bsa2` is loaded from the stack using a `mov r15, [rbp+Cc4_OffsetStackArgs]` instruction. The symbolic constant `Cc4_OffsetStackArgs` also was automatically generated by the macro `_CreateFrame` and equates to the offset of the first stack argument relative to the RBP register. A `mov rbx, [rbp+Cc4_OffsetStackArgs+8]` instruction loads argument `bsa3` into register `RBX`; the constant `+8` is included as part of the source operand displacement since `bsa3` is the second argument passed via the stack.

The Visual C++ calling convention requires the caller of a function to allocate the home area of any called function. The `sub rsp, 32` instruction performs this operation. The ensuing block of code calculates the BSA values using the equations shown in Table 18-2. Note that registers `XMM0` and `XMM1` are loaded with the necessary argument values prior to each call to `pow`. Also note that some of the return values from `pow` are preserved in non-volatile XMM registers prior to their actual use.

Following completion of the BSA processing loop is the function epilog. Before execution of the `ret` instruction, the `Cc4_` function must restore all non-volatile XMM and general-purpose registers that it saved in the prolog. The stack frame must also be properly deleted. The `_RestoreXmmRegs` macro restores the non-volatile XMM registers. Note that this macro requires the order of the registers in its argument list to match the register list that was used with the `_SaveXmmRegs` macro. Stack frame cleanup and general-purpose register restores are handled by the `_DeleteFrame` macro. The order of the registers specified in this macro's argument list must be identical to the prolog's `_CreateFrame` macro. Note that the `_DeleteFrame` macro restores register `RSP` from `RBP`, which means that it's not necessary to include an explicit `add rsp, 32` instruction to release the `pow` function home area. Output 18-8 shows the results of the sample program `CallingConvention4`.

Output 18-8. Sample Program `CallingConvention4`

Results for `CallingConvention4`

```
height: 150.0 cm
weight: 50.0 kg
BSA (C++):      1.432500   1.460836   1.443376 (sq. m)
BSA (X86-64):  1.432500   1.460836   1.443376 (sq. m)
```

```

height: 160.0 cm
weight: 60.0 kg
BSA (C++):      1.622063    1.648868    1.632993 (sq. m)
BSA (X86-64):  1.622063    1.648868    1.632993 (sq. m)

```

```

height: 170.0 cm
weight: 70.0 kg
BSA (C++):      1.809708    1.831289    1.818119 (sq. m)
BSA (X86-64):  1.809708    1.831289    1.818119 (sq. m)

```

```

height: 180.0 cm
weight: 80.0 kg
BSA (C++):      1.996421    2.009483    2.000000 (sq. m)
BSA (X86-64):  1.996421    2.009483    2.000000 (sq. m)

```

```

height: 190.0 cm
weight: 90.0 kg
BSA (C++):      2.182809    2.184365    2.179449 (sq. m)
BSA (X86-64):  2.182809    2.184365    2.179449 (sq. m)

```

```

height: 200.0 cm
weight: 100.0 kg
BSA (C++):      2.369262    2.356574    2.357023 (sq. m)
BSA (X86-64):  2.369262    2.356574    2.357023 (sq. m)

```

X86-64 Arrays and Strings

The sample programs in this section illustrate how to use the x86-64 instruction set to manipulate common programming constructs. The first program demonstrates using 64-bit pointer arithmetic to process the elements of a two-dimensional array. The second sample program exemplifies use of several x86 string instructions. Both of these sample programs exploit the calling convention macros that you learned about in the previous section.

Two-Dimensional Arrays

In Chapter 2, you learned how to implement a two-dimensional array or matrix using a contiguous block of memory and simple pointer arithmetic. The sample program in this section uses the same pointer arithmetic techniques to implement an x86-64 matrix multiplication function. Listings 18-17 and 18-18 show the C++ and assembly language source code for sample program `MatrixMul`.

Listing 18-17. MatrixMul.cpp

```

#include "stdafx.h"
#include <stdlib.h>

extern "C" double* MatrixMul_(const double* m1, int nr1, int nc1, const
double* m2, int nr2, int nc2);

void MatrixPrint(const double* m, int nr, int nc, const char* s)
{
    printf("%s\n", s);

    if (m != NULL)
    {
        for (int i = 0; i < nr; i++)
        {
            for (int j = 0; j < nc; j++)
            {
                double m_val = m[i * nc + j];
                printf("%8.11f ", m_val);
            }
            printf("\n");
        }
    }
    else
        printf("NULL pointer\n");
}

double* MatrixMulCpp(const double* m1, int nr1, int nc1, const double* m2,
int nr2, int nc2)
{
    if ((nr1 < 0) || (nc1 < 0) || (nr2 < 0) || (nc2 < 0))
        return NULL;
    if (nc1 != nr2)
        return NULL;

    double* m3 = (double*)malloc(nr1 * nc2 * sizeof(double));

    for (int i = 0; i < nr1; i++)
    {
        for (int j = 0; j < nc2; j++)
        {
            double sum = 0;

```

```

        for (int k = 0; k < nc1; k++)
        {
            double m1_val = m1[i * nc1 + k];
            double m2_val = m2[k * nc2 + j];
            sum += m1_val * m2_val;
        }
        m3[i * nc2 + j] = sum;
    }
}

return m3;
}

void MatrixMul1(void)
{
    const int nr1 = 3;
    const int nc1 = 2;
    const int nr2 = 2;
    const int nc2 = 3;
    double m1[nr1 * nc1] = { 6, 2, 4, 3, -5, -2 };
    double m2[nr2 * nc2] = { -2, 3, 4, -3, 6, 7 };
    double* m3_a = MatrixMulCpp(m1, nr1, nc1, m2, nr2, nc2);
    double* m3_b = MatrixMul_(m1, nr1, nc1, m2, nr2, nc2);

    printf("\nResults for MatrixMul1()\n");
    MatrixPrint(m1, nr1, nc1, "Matrix m1");
    MatrixPrint(m2, nr2, nc2, "Matrix m2");
    MatrixPrint(m3_a, nr1, nc2, "Matrix m3_a");
    MatrixPrint(m3_b, nr1, nc2, "Matrix m3_b");
    free(m3_a);
    free(m3_b);
}

void MatrixMul2(void)
{
    const int nr1 = 2;
    const int nc1 = 3;
    const int nr2 = 3;
    const int nc2 = 4;
    double m1[nr1 * nc1] = { 5, -3, 2, -2, 5, 4 };
    double m2[nr2 * nc2] = { 7, -4, 3, 3, 2, 6, -2, 5, 4, 9, 3, 5 };
    double* m3_a = MatrixMulCpp(m1, nr1, nc1, m2, nr2, nc2);
    double* m3_b = MatrixMul_(m1, nr1, nc1, m2, nr2, nc2);

    printf("\nResults for MatrixMul2()\n");
    MatrixPrint(m1, nr1, nc1, "Matrix m1");
    MatrixPrint(m2, nr2, nc2, "Matrix m2");
}

```

```

    MatrixPrint(m3_a, nr1, nc2, "Matrix m3_a");
    MatrixPrint(m3_b, nr1, nc2, "Matrix m3_b");
    free(m3_a);
    free(m3_b);
}

int _tmain(int argc, _TCHAR* argv[])
{
    MatrixMul1();
    MatrixMul2();
    return 0;
}

```

Listing 18-18. MatrixMul_.asm

```

    include <MacrosX86-64.inc>
    .code
    extern malloc:proc

; extern "C" double* MatrixMul_(const double* m1, int nr1, int nc1, const
double* m2, int nr2, int nc2);
;
; Description: The following function computes the product of two
;               matrices.

MatrixMul_ proc frame
    _CreateFrame MatMul_,0,0,rbx,r12,r13,r14,r15
    _EndProlog

; Verify the matrix size values.
    movsxd r12,edx                ;r12 = nr1
    test r12,r12
    jle Error                    ;jump if nr1 <= 0

    movsxd r13,r8d               ;r13 = nc1
    test r13,r13
    jle Error                    ;jump if nc1 <= 0

    movsxd r14,dword ptr [rbp+MatMul_OffsetStackArgs] ;r14 = nr2
    test r14,r14
    jle Error                    ;jump if nr2 <= 0

    movsxd r15,dword ptr [rbp+MatMul_OffsetStackArgs+8] ;r15 = nc2
    test r15,r15
    jle Error                    ;jump if nc2 <= 0

    cmp r13,r14
    jne Error                    ;jump if nc1 != nr2

```

```

; Allocate storage
mov [rbp+MatMul_OffsetHomeRCX],rcx ;save m1
mov [rbp+MatMul_OffsetHomeR9],r9  ;save m2
mov rcx,r12                        ;rcx = nr1
imul rcx,r15                       ;rcx = nr1 * nc2
shl rcx,3                          ;rcx = nr1 * nc2 * size real8
sub rsp,32                          ;allocate home space
call malloc
mov rbx,rax                        ;rbx = ptr to m3

; Initialize source matrix pointers and row index i
mov rcx,[rbp+MatMul_OffsetHomeRCX] ;rcx = ptr to m1
mov rdx,[rbp+MatMul_OffsetHomeR9]  ;rdx = ptr to m2
xor r8,r8                          ;i = 0

; Initialize column index j
Lp1:  xor r9,r9                      ;j = 0

; Initialize sum and index k
Lp2:  xorpd xmm4,xmm4                ;sum = 0;
      xor r10,r10                   ;k = 0;

; Calculate sum += m1[i * nc1 + k] * m2[k * nc2 + j]
Lp3:  mov rax,r8                    ;rax = i
      imul rax,r13                  ;rax = i * nc1
      add rax,r10                   ;rax = i * nc1 + k
      movsd xmm0,real8 ptr [rcx+rax*8] ;xmm0 = m1[i * nc1 + k]

      mov r11,r10                   ;r11 = k;
      imul r11,r15                  ;r11 = k * nc2
      add r11,r9                    ;r11 = k * nc2 + j
      movsd xmm1,real8 ptr [rdx+r11*8] ;xmm1 = m2[k * nc2 + j]

      mulsd xmm0,xmm1               ;xmm0 = m1[i * nc1 + k] * m2[k * nc2 + j]
      addsd xmm4,xmm0               ;update sum

      inc r10                       ;k++
      cmp r10,r13                   ;jump if k < nc1
      jl Lp3

; Save sum to m3[i * nc2 + j]
mov rax,r8                          ;rax = i
imul rax,r15                         ;rax = i * nc2
add rax,r9                           ;rax = i * nc2 + j
movsd real8 ptr [rbx+rax*8],xmm4     ;m3[i * nc2 + j] = sum

```

```

; Update loop counters and repeat until done
    inc r9                                ;j++
    cmp r9,r15
    jl Lp2                                ;jump if j < nc2
    inc r8                                ;i++
    cmp r8,r12
    jl Lp1                                ;jump if i < nr1

    mov rax,rbx                            ;rax = ptr to m3

Done:  _DeleteFrame rbx,r12,r13,r14,r15
    ret

Error:  xor rax,rax                        ;return NULL
    jmp Done
MatrixMul_ endp
end

```

The product of two matrices is defined as follows. Let **A** be a matrix of m rows and n columns, and **B** a matrix of n rows and p columns. The elements of the matrix **C** = **AB**, where **C** is a matrix of m rows and p columns, are computed as follows:

$$c_{ij} = \sum_{k=0}^{n-1} a_{ik} b_{kj} \quad i=0, \dots, m-1, j=0, \dots, p-1$$

The source code file `MatrixMul.cpp` (see Listing 18-17) contains a function named `MatrixMulCpp` that computes the product of two matrices. Following validation of the matrix sizes, the function `MatrixMulCpp` calls `malloc` to dynamically allocate a block of memory for the product matrix. It then multiplies the two sources matrices using the previously defined equation. The remaining code in `MatrixMul.cpp` establishes a couple of matrix multiplication test cases and prints the results for comparison purposes.

Listing 18-18 contains the x86-64 assembly language code for the `MatrixMul_` function. Immediately after the `MatrixMul_ proc` frame statement, the `_CreateFrame` macro is employed to save the appropriate non-volatile general-purpose registers and initialize a stack frame pointer. Note that both stack size parameters of the `_CreateFrame` macro are zero since the `MatrixMul_` function does not require any local variable space and there is no need to preserve any of the non-volatile XMM registers. The matrix size arguments `nr1`, `nc1`, `nr2`, `nc2`, are then loaded into registers `R12`, `R13`, `R14`, and `R15`, respectively. Note that `nr1` and `nc1` were passed to `MatrixMul_` in registers `EDX` and `R8D` while the latter two were passed via the stack.

The storage space for the destination matrix is then allocated using the standard library function `malloc`. Prior to calling `malloc`, the source matrix pointers `m1` and `m2` are saved to their respective home areas on the stack since they were passed to `MatrixMul_` using volatile registers `RCX` and `R9`, respectively. Also note that a `sub rsp, 32` instruction is employed just before the `call malloc` instruction, which allocates the obligatory home area for `malloc`.

Following allocation of the destination matrix memory block, the source matrix pointers `m1` and `m2` are loaded into registers `RCX` and `RDX`, respectively. The function then calculates the matrix product using the same three-loop construct as its C++ counterpart. All double-precision floating-point arithmetic is carried out using volatile XMM registers. Upon completion of the matrix multiplication processing loop, the `_DeleteFrame` macro is used to restore the previously-saved non-volatile general-purpose registers. The results of sample program `MatrixMul` are shown in Output 18-9.

Output 18-9. Sample Program `MatrixMul`

Results for `MatrixMul1()`

Matrix `m1`

6.0	2.0
4.0	3.0
-5.0	-2.0

Matrix `m2`

-2.0	3.0	4.0
-3.0	6.0	7.0

Matrix `m3_a`

-18.0	30.0	38.0
-17.0	30.0	37.0
16.0	-27.0	-34.0

Matrix `m3_b`

-18.0	30.0	38.0
-17.0	30.0	37.0
16.0	-27.0	-34.0

Results for `MatrixMul2()`

Matrix `m1`

5.0	-3.0	2.0
-2.0	5.0	4.0

Matrix `m2`

7.0	-4.0	3.0	3.0
2.0	6.0	-2.0	5.0
4.0	9.0	3.0	5.0

Matrix `m3_a`

37.0	-20.0	27.0	10.0
12.0	74.0	-4.0	39.0

Matrix `m3_b`

37.0	-20.0	27.0	10.0
12.0	74.0	-4.0	39.0

Strings

The final sample program in this section and chapter is named `ConcatStrings`. This sample program is an x86-64 implementation of the x86-32 string concatenation program that you studied in Chapter 2, which illustrated how to use the `scasw` and `movsw` instructions to concatenate multiple strings. Listings 18-19 and 18-20 contain the C++ and assembly language source code for sample program `ConcatStrings`.

Listing 18-19. `ConcatStrings.cpp`

```
#include "stdafx.h"

extern "C" int ConcatStrings_(wchar_t* des, int des_size, const wchar_t*
const* src, int src_n);

int _tmain(int argc, _TCHAR* argv[])
{
    printf("\nResults for ConcatStrings\n");

    // Destination buffer large enough
    wchar_t* src1[] = { L"One ", L"Two ", L"Three ", L"Four " };
    int src1_n = sizeof(src1) / sizeof(wchar_t*);
    const int des1_size = 64;
    wchar_t des1[des1_size];

    int des1_len = ConcatStrings_(des1, des1_size, src1, src1_n);
    wchar_t* des1_temp = (*des1 != '\0') ? des1 : L"<empty>";
    wprintf(L" des_len: %d (%d) des: %s \n", des1_len, wcslen(des1_temp),
des1_temp);

    // Destination buffer too small
    wchar_t* src2[] = { L"Red ", L"Green ", L"Blue ", L"Yellow " };
    int src2_n = sizeof(src2) / sizeof(wchar_t*);
    const int des2_size = 16;
    wchar_t des2[des2_size];

    int des2_len = ConcatStrings_(des2, des2_size, src2, src2_n);
    wchar_t* des2_temp = (*des2 != '\0') ? des2 : L"<empty>";
    wprintf(L" des_len: %d (%d) des: %s \n", des2_len, wcslen(des2_temp),
des2_temp);

    // Empty string test
    wchar_t* src3[] = { L"Airplane ", L"Car ", L"", L"Truck ", L"Boat " };
    int src3_n = sizeof(src3) / sizeof(wchar_t*);
    const int des3_size = 128;
    wchar_t des3[des3_size];
```

```

    int des3_len = ConcatStrings_(des3, des3_size, src3, src3_n);
    wchar_t* des3_temp = (*des3 != '\0') ? des3 : L"<empty>";
    wprintf(L" des_len: %d (%d) des: %s \n", des3_len, wcslen(des3_temp),
    des3_temp);

    return 0;
}

```

Listing 18-20. ConcatStrings_.asm

```

    include <MacrosX86-64.inc>
    .code

; extern "C" int ConcatStrings_(wchar_t* des, int des_size, const wchar_t*
const* src, int src_n)
;
; Description: This function performs string concatenation using
;              multiple input strings.
;
; Returns:     -1          Invalid des_size or src_n
;              n >= 0     Length of concatenated string

ConcatStrings_ proc frame
    _CreateFrame ConcatStrings_,0,0,rbx,rsi,rdi
    _EndProlog

; Make sure des_size and src_n are greater than zero
    movsxd rdx,edx                ;rdx = des_size
    test rdx,rdx
    jle Error                    ;jump if des_size <= 0
    movsxd r9,r9d                ;r9 = src_n
    test r9,r9
    jle Error                    ;jump if src_n <= 0

; Perform required initializations
    mov rbx,rcx                  ;rbx = des
    xor r10,r10                  ;des_index = 0
    xor r11,r11                  ;i = 0
    mov word ptr [rbx],r10w      ;*des = '\0';

; Repeat loop until concatenation is finished
lp1:  mov rdi,[r8+r11*8]          ;rdi = src[i]
      mov rsi,rdi                ;rsi = src[i]

; Compute length of s[i]
    xor rax,rax
    mov rcx,-1

```



```

    repne scasw                ;find '\0'
    not rcx
    dec rcx                    ;rcx = len(src[i])

; Compute des_index + src_len
    mov rax,r10                ;rax= des_index
    add rax,rcx                ;rax = des_index + len(src[i])

; Is des_index + src_len >= des_size?
    cmp rax,rdx
    jge Done

; Copy src[i] to &des[des_index] (rsi already contains src[i])
    inc rcx                    ;rcx = len(src[i]) + 1
    lea rdi,[rbx+r10*2]        ;rdi = &des[des_index]
    rep movsw                  ;perform string move

; Update des_index
    mov r10,rax                ;des_index += len(src[i])

; Update i and repeat if not done
    inc r11                    ;i += 1
    cmp r11,r9                 ;is i >= src_n?
    jl Lp1                     ;jump if i < src_n

; Return length of concatenated string
Done:  mov eax,r10d            ;eax = trunc(des_index)
    _DeleteFrame rbx,rsi,rdi
    ret

; Return error code
Error: mov eax,-1             ;eax = error code
    _DeleteFrame rbx,rsi,rdi
    ret

ConcatStrings_ endp
end

```

The source code file `ConcatStrings.cpp` (see Listing 18-19) is identical to the one that was used in Chapter 2. It simply sets up a couple of test cases to exercise the assembly language function `ConcatStrings_` and displays the results. Listing 18-20 shows the x86-64 code for `ConcatStrings_`. Since this function doesn't require any local storage, the `_CreateFrame` macro is used solely to save the contents of non-volatile registers `RBX`, `RSI`, and `RDI`. The function then validates the size arguments `des_size` (`RDX`) and `src_n` (`R9`). Note that these values are sign-extended to 64 bits prior to validation in order to simplify the compare operations in the main processing loop.

A `mov rbx,rcx` instruction copies the argument `des` into register `RBX` since `RCX` must be used as the count register by `scasw` and `movsw`. The main processing loop commences with a `mov rdi,[r8+r11*8]` instruction that loads `src[i]` into register `RDI`. A scale factor of eight is used since each string address in `src[i]` is eight bytes wide. Next, the length of string `src[i]` is calculated using the `scasw` instruction. The function then verifies that sufficient space is available in `des` to accommodate the new string. If enough space is available, a `movsw` instruction concatenates the string `src[i]` to the existing string in `des`; otherwise the processing loop terminates. The processing loop is then repeated until all strings in `src` have been processed or sufficient space is no longer available.

The `ConcatStrings_` function contains two epilogs. While this approach is inconsequential in `ConcatStrings_`, the use of multiple epilogs may improve the performance of some functions compared to the execution of additional `jmp` instructions. Note that both epilogs use the `_DeleteFrame` macro to restore the previously-saved non-volatile registers. Output 18-10 shows the results of the sample program `ConcatStrings`.

Output 18-10. Sample Program `ConcatStrings`

Results for `ConcatStrings`

```
des_len: 18 (18) des: One Two Three Four
des_len: 15 (15) des: Red Green Blue
des_len: 24 (24) des: Airplane Car Truck Boat
```

Summary

This chapter focused on x86-64 core architecture assembly language programming. You learned about the fundamentals of x86-assembly language programming, including integer arithmetic and operands, memory addressing, and scalar floating-point arithmetic. You also acquired practical knowledge and experience regarding the calling convention and its requirements. In the next two chapters, you continue your exploration of the x86-64 platform with an examination of its SIMD components.



X86-64 SIMD Architecture

The previous two chapters focused on the fundamentals of the x86-64 platform and its core architecture. In this chapter, exploration of the x86-64 platform continues with an examination of its SIMD architecture, which includes the computational resources of x86-SSE and x86-AVX. In the first section, you learn about the 64-bit x86-SSE execution environment, including its register set, supported data types, and instruction sets. The second section contains a similarly-ordered discussion that focuses on the 64-bit x86-AVX execution environment.

The content of this chapter assumes that you have a basic understanding of the material presented earlier in this book regarding x86-SSE and x86-AVX. This chapter is intentionally brief given the high degree of similarity between the SIMD architectures on the x86-32 and x86-64 platforms. In the discussions that follow, a “-32” or “-64” suffix is appended to the terms x86-SSE and x86-AVX when necessary in order to differentiate between the 32-bit and 64-bit SIMD architectures.

X86-SSE-64 Execution Environment

The following section discusses the execution environment of x86-SSE-64, including its register set and supported data types. From the perspective of an application program, most of the differences between the x86-SSE-64 and x86-SSE-32 execution environments are minor. Both environments use the same instructions, operands, and packed data types.

As mentioned in Chapter 17, all x86-64 compatible processors include the computational resources of SSE2. X86-64 processor support for extensions subsequent to SSE2 (SSE3, SSSE3, SSE4.1, and SSE4.2) varies depending on the particular microarchitecture. An application program should use the `cquid` instruction to test whether a specific post-SSE2 extension is available for use.

X86-SSE-64 Register Set

The x86-SSE-64 register set includes 16 128-bit registers, which are named XMM0-XMM15. These are illustrated in Figure 19-1. The XMM registers support SIMD operations using packed integer operands. They also can be used to perform scalar and packed floating-point calculations using single-precision and double-precision values.

127	XMM0	0
	XMM1	
	XMM2	
	XMM3	
	XMM4	
	XMM5	
	XMM6	
	XMM7	
	XMM8	
	XMM9	
	XMM10	
	XMM11	
	XMM12	
	XMM13	
	XMM14	
	XMM15	

Figure 19-1. X86-SSE-64 register set

An x86-64 assembly language function can use the X86-SSE control-status register MXCSR to select SIMD floating-point configuration options. The status bits in MXCSR can also be tested to detect SIMD floating-point error conditions. The purpose and operation of each control flag and status bit in MXCSR is the same in both the x86-64 and x86-32 execution environments, and are explained in Chapter 7, particularly in Figure 7-3 and Table 7-2. Chapter 8 contains an example program that illustrates use of the MXCSR.

X86-SSE-64 Data Types

X86-SSE-64 supports the same data types as its 32-bit counterpart. This includes pack integers (8-, 16-, 32-, and 64-bit), scalar floating-point (32-bit single-precision and 64-bit double-precision), and packed floating-point (32-bit single-precision and 64-bit double-precision). Figure 7-2 illustrates the X86-SSE data types. Except for a small subset of instructions, all 128-bit wide packed integer and floating-point operands in memory must be properly aligned on a 16-byte boundary. Alignment of scalar floating-point operands is not required but strongly recommended for performance reasons. Chapter 7 contains additional information regarding x86-SSE data types.

X86-SSE-64 Instruction Set Overview

The x86-SSE-64 instruction set is essentially the same as its 32-bit analogue, except for a small subset of instructions that require general-purpose register operands. All X86-SSE instructions that employ general-purpose register operands have been extended to support the 64-bit general-purpose register set. Table 19-1 lists the X86-SSE instructions that can be used with a 64-bit general-purpose register operand. The table descriptions use the acronyms DPFPP and SPFP to represent double-precision floating-point and single-precision floating-point, respectively.

Table 19-1. X86-SSE 64-Bit General-Purpose Register Instructions

Mnemonic	Description
cvtsd2si	Convert scalar DPFPP to signed integer
cvtsi2sd	Convert signed integer to scalar DPFPP
cvtsi2ss	Convert signed integer to scalar SPFP
cvts2si	Convert scalar SPFP to signed integer
cvtt2si	Convert with truncation scalar DPFPP to signed integer
cvts2si	Convert with truncation scalar SPFP to signed integer
movmskpd	Extract packed DPFPP sign mask
movmskps	Extract packed SPFP sign mask
movq	Move quadword
pextrq	Extract quadword
pinsrq	Insert quadword
pmovmskb	Move byte mask

Execution of x86-SSE instructions is the same in both 64-bit and 32-bit processor operating modes. When operating in 64-bit mode, some of the x86-SSE packed text string instructions use 64-bit instead of 32-bit implicit register operands. For example, the string fragment lengths required by the `pcmpestri` and `pcmpestrm` instructions must be loaded into registers RAX and RDX instead of EAX and EDX. Also, the `pcmpestri` and `pcmpistri` instructions store the calculated character index in RCX instead of ECX.

X86-AVX Execution Environment

The following section discusses the execution environment of x86-AVX-64, including its register set and supported data types. Similar to x86-SSE, most of the differences between the X86-AVX-64 and X86-AVX-32 execution environments are relatively minor. It should be noted that not all x86-64 compatible processors support x86-AVX. An application program should use the `cpuid` instruction to test whether the host processor supports AVX, AVX2, or any of the x86-AVX concomitant feature set extensions such as FMA.

X86-AVX-64 Register Set

The x86-AVX-64 register set contains 16 256-bit registers, which are named YMM0-YMM15. These registers can be used to manipulate a variety of data types including packed integer, packed floating-point, and scalar floating-point values. The low-order 128-bits of each YMM register are aliased with the corresponding XMM register, as illustrated in Figure 19-2. Most x86-AVX-64 instructions can use any of the XMM or YMM registers as operands.

255	128 127	0
	YMM0	XMM0
	YMM1	XMM1
	YMM2	XMM2
	YMM3	XMM3
	YMM4	XMM4
	YMM5	XMM5
	YMM6	XMM6
	YMM7	XMM7
	YMM8	XMM8
	YMM9	XMM9
	YMM10	XMM10
	YMM11	XMM11
	YMM12	XMM12
	YMM13	XMM13
	YMM14	XMM14
	YMM15	XMM15

Figure 19-2. X86-AVX-64 register set

X86-AVX-64 Data Types

X86-AVX-64 supports the same data types as x86-AVX-32, including packed integers, scalar floating-point, and packed floating-point. Chapter 12 discusses these data types in greater detail; they're also illustrated in Figure 12-2. Most x86-AVX instructions can manipulate 128-bit or 256-bit wide packed operands using either an XMM or YMM register, respectively. The relaxed memory alignment requirements discussed in Chapter 12 also apply to x86-AVX-64 operands in memory. To reiterate, except for data transfer instructions that explicitly reference an aligned 128-bit or 256-bit wide operand in memory, proper alignment of an x86-AVX operand is not required but strongly recommended for best possible performance.

X86-AVX-64 Instruction Set Overview

Excluding the instructions that require a general-purpose register operand, the x86-AVX-64 instruction set is basically the same as its 32-bit counterpart. The x86-AVX forms of the instructions listed in Table 19-1 are permitted to use 64-bit general-purpose register operands. Instructions that use VSIB memory addressing (such as `vgatherdpd`, `vgatherdps`, and so on) can also specify a 64-bit general-purpose register as the base register operand.

Execution of x86-AVX instructions does not vary between 64-bit and 32-bit operating modes. This includes the zeroing of a YMM register's upper 128 bits when the corresponding XMM register is used as an operand, and the processing rules that affect the unused bits of an x86-AVX scalar floating-point operand. X86-64 assembly language functions should also use the `vzeroupper` or `vzeroall` instructions to avoid potential state transition delays that can occur when switching between x86-AVX and x86-SSE instructions. Chapter 12 discusses these and other x86-AVX instruction set programming issues in greater detail.

Summary

In this chapter, you learned about the x86-SSE-64 and x86-AVX-64 architectures. You also discovered that these 64-bit SIMD architectures are very similar to their 32-bit counterparts. The larger register sets afforded by x86-SSE-64 and x86-AVX-64 offer a number of benefits, including simplified assembly language coding and opportunities for increased performance. In the next chapter, you examine a variety of sample programs that expound on the material presented in this chapter.



X86-64 SIMD Programming

This chapter explains how to code x86-64 assembly language functions that exploit the computational resources of x86-SSE and x86-AVX. The first section includes sample code that focuses on use of the x86-SSE instruction set. The second section exemplifies operation of the x86-AVX instruction set. Most of the x86-SSE and x86-AVX instructions exercised by the sample code in this chapter have already been examined in previous chapters. This allows the ensuing discussions to place more emphasis on algorithmic techniques and 64-bit processing methods instead of instruction execution minutiae.

X86-SSE-64 Programming

In Chapters 9 and 10, you learned how to use the x86-SSE instruction set to write functions that process packed floating-point and integer data. In this section, you discover how to exploit the resources of x86-SSE in a 64-bit assembly language function. The first sample program is a 64-bit implementation of the image histogram construction algorithm that was discussed in Chapter 10. The next two sample programs illustrate use of the x86-SSE instruction set with packed floating-point data. All of the sample programs in this section accentuate application of the additional computing resources that are available in an x86-64 execution environment.

Image Histogram

In Chapter 10, you learned how to construct a histogram for an 8-bit grayscale image using the x86-SSE instruction set. In this section, you examine a 64-bit implementation of the same image-histogram processing algorithm. Listings 20-1 and 20-2 show the C++ and assembly language source code for sample program `Sse64ImageHistogram`.

Listing 20-1. Sse64ImageHistogram.cpp

```

#include "stdafx.h"
#include "Sse64ImageHistogram.h"
#include <string.h>
#include <malloc.h>

extern "C" UInt32 NUM_PIXELS_MAX = 16777216;

bool Sse64ImageHistogramCpp(UInt32* histo, const UInt8* pixel_buff, UInt32
num_pixels)
{
    // Make sure num_pixels is valid
    if ((num_pixels == 0) || (num_pixels > NUM_PIXELS_MAX))
        return false;
    if (num_pixels % 32 != 0)
        return false;

    // Make sure histo is aligned to a 16-byte boundary
    if (((uintptr_t)histo & 0xf) != 0)
        return false;

    // Make sure pixel_buff is aligned to a 16-byte boundary
    if (((uintptr_t)pixel_buff & 0xf) != 0)
        return false;

    // Build the histogram
    memset(histo, 0, 256 * sizeof(UInt32));

    for (UInt32 i = 0; i < num_pixels; i++)
        histo[pixel_buff[i]]++;

    return true;
}

void Sse64ImageHistogram(void)
{
    const wchar_t* image_fn = L"..\\..\\..\\DataFiles\\TestImage1.bmp";
    const char* csv_fn = "__TestImage1_Histograms.csv";

    ImageBuffer ib(image_fn);
    UInt32 num_pixels = ib.GetNumPixels();
    UInt8* pixel_buff = (UInt8*)ib.GetPixelBuffer();
    UInt32* histo1 = (UInt32*)_aligned_malloc(256 * sizeof(UInt32), 16);
    UInt32* histo2 = (UInt32*)_aligned_malloc(256 * sizeof(UInt32), 16);
    bool rc1, rc2;

```

```

rc1 = Sse64ImageHistogramCpp(histo1, pixel_buff, num_pixels);
rc2 = Sse64ImageHistogram_(histo2, pixel_buff, num_pixels);

printf("Results for Sse64ImageHistogram()\n");

if (!rc1 || !rc2)
{
    printf(" Bad return code: rc1=%d, rc2=%d\n", rc1, rc2);
    return;
}

FILE* fp;
bool compare_error = false;

if (fopen_s(&fp, csv_fn, "wt") != 0)
    printf(" File open error: %s\n", csv_fn);
else
{
    for (UInt32 i = 0; i < 256; i++)
    {
        fprintf(fp, "%u, %u, %u\n", i, histo1[i], histo2[i]);

        if (histo1[i] != histo2[i])
        {
            printf(" Histogram compare error at index %u\n", i);
            printf(" counts: [%u, %u]\n", histo1[i], histo2[i]);
            compare_error = true;
        }
    }

    if (!compare_error)
        printf(" Histograms are identical\n");

    fclose(fp);
}
}

int _tmain(int argc, _TCHAR* argv[])
{
    try
    {
        Sse64ImageHistogram();
        Sse64ImageHistogramTimed();
    }
}

```

```

    catch (...)
    {
        printf("Unexpected exception has occurred!\n");
        printf("File: %s (_tmain)\n", __FILE__);
    }

    return 0;
}

```

Listing 20-2. Sse64ImageHistogram_.asm

```

    include <MacrosX86-64.inc>
    .code
    extern NUM_PIXELS_MAX:dword

; extern bool Sse64ImageHistogram_(UInt32* histo, const UInt8* pixel_buff,
; UInt32 num_pixels);
;
; Description: The following function builds an image histogram.
;
; Returns:      0 = invalid argument value
;              1 = success
;
; Requires:    X86-64, SSE4.1

Sse64ImageHistogram_ proc frame
    _CreateFrame Sse64Ih_,1024,0,rbx,rsi,rdi
    _EndProlog

; Make sure num_pixels is valid
    test r8d,r8d
    jz Error                ;jump if num_pixels is zero
    cmp r8d,[NUM_PIXELS_MAX]
    ja Error                ;jump if num_pixels too big
    test r8d,1fh
    jnz Error               ;jump if num_pixels % 32 != 0

; Make sure histo & pixel_buff are properly aligned
    mov rsi,rcx
    test rsi,0fh
    jnz Error                ;jump if histo misaligned
    mov r9,rdx
    test r9,0fh
    jnz Error                ;jump if pixel_buff misaligned

```

```

; Initialize local histogram buffers (set all entries to zero)
    xor rax,rax
    mov rdi,rsi                                ;rdi = ptr to histo
    mov rcx,128                                ;rcx = size in qwords
    rep stosq                                  ;zero histo
    mov rdi,rbp                                ;rdi = ptr to histo2
    mov rcx,128                                ;rcx = size in qwords
    rep stosq                                  ;zero histo2

; Perform processing loop initializations
    shr r8d,5                                  ;r8d = number of pixel blocks
    mov rdi,rbp                                ;rdi = ptr to histo2

; Build the histograms
    align 16                                    ;align jump target
@@:    movdqa xmm0,[r9]                        ;load pixel block
    movdqa xmm2,[r9+16]                       ;load pixel block
    movdqa xmm1,xmm0
    movdqa xmm3,xmm2

; Process pixels 0 - 3
    pextrb rax,xmm0,0
    add dword ptr [rsi+rax*4],1                ;count pixel 0
    pextrb rbx,xmm1,1
    add dword ptr [rdi+rbx*4],1                ;count pixel 1
    pextrb rcx,xmm0,2
    add dword ptr [rsi+rcx*4],1                ;count pixel 2
    pextrb rdx,xmm1,3
    add dword ptr [rdi+rdx*4],1                ;count pixel 3

; Process pixels 4 - 7
    pextrb rax,xmm0,4
    add dword ptr [rsi+rax*4],1                ;count pixel 4
    pextrb rbx,xmm1,5
    add dword ptr [rdi+rbx*4],1                ;count pixel 5
    pextrb rcx,xmm0,6
    add dword ptr [rsi+rcx*4],1                ;count pixel 6
    pextrb rdx,xmm1,7
    add dword ptr [rdi+rdx*4],1                ;count pixel 7

; Process pixels 8 - 11
    pextrb rax,xmm0,8
    add dword ptr [rsi+rax*4],1                ;count pixel 8
    pextrb rbx,xmm1,9
    add dword ptr [rdi+rbx*4],1                ;count pixel 9

```

```

    pextrb rcx,xmm0,10
    add dword ptr [rsi+rcx*4],1           ;count pixel 10
    pextrb rdx,xmm1,11
    add dword ptr [rdi+rdx*4],1         ;count pixel 11

; Process pixels 12 - 15
    pextrb rax,xmm0,12
    add dword ptr [rsi+rax*4],1         ;count pixel 12
    pextrb rbx,xmm1,13
    add dword ptr [rdi+rbx*4],1         ;count pixel 13
    pextrb rcx,xmm0,14
    add dword ptr [rsi+rcx*4],1         ;count pixel 14
    pextrb rdx,xmm1,15
    add dword ptr [rdi+rdx*4],1         ;count pixel 15

; Process pixels 16 - 19
    pextrb rax,xmm2,0
    add dword ptr [rsi+rax*4],1         ;count pixel 16
    pextrb rbx,xmm3,1
    add dword ptr [rdi+rbx*4],1         ;count pixel 17
    pextrb rcx,xmm2,2
    add dword ptr [rsi+rcx*4],1         ;count pixel 18
    pextrb rdx,xmm3,3
    add dword ptr [rdi+rdx*4],1         ;count pixel 19

; Process pixels 20 - 23
    pextrb rax,xmm2,4
    add dword ptr [rsi+rax*4],1         ;count pixel 20
    pextrb rbx,xmm3,5
    add dword ptr [rdi+rbx*4],1         ;count pixel 21
    pextrb rcx,xmm2,6
    add dword ptr [rsi+rcx*4],1         ;count pixel 22
    pextrb rdx,xmm3,7
    add dword ptr [rdi+rdx*4],1         ;count pixel 23

; Process pixels 24 - 27
    pextrb rax,xmm2,8
    add dword ptr [rsi+rax*4],1         ;count pixel 24
    pextrb rbx,xmm3,9
    add dword ptr [rdi+rbx*4],1         ;count pixel 25
    pextrb rcx,xmm2,10
    add dword ptr [rsi+rcx*4],1         ;count pixel 26
    pextrb rdx,xmm3,11
    add dword ptr [rdi+rdx*4],1         ;count pixel 27

```

```

; Process pixels 28 - 31
    pextrb rax,xmm2,12
    add dword ptr [rsi+rax*4],1           ;count pixel 28
    pextrb rbx,xmm3,13
    add dword ptr [rdi+rbx*4],1         ;count pixel 29
    pextrb rcx,xmm2,14
    add dword ptr [rsi+rcx*4],1         ;count pixel 30
    pextrb rdx,xmm3,15
    add dword ptr [rdi+rdx*4],1         ;count pixel 31

    add r9,32                             ;r9 = next pixel block
    sub r8d,1
    jnz @B                                 ;repeat loop if not done

; Merge intermediate histograms into final histogram
    mov ecx,32                             ;ecx = num iterations
    xor rax,rax                             ;rax = common offset

@@:   movdq xmm0,xmmword ptr [rsi+rax]       ;load histo counts
    movdq xmm1,xmmword ptr [rsi+rax+16]
    paddq xmm0,xmmword ptr [rdi+rax]       ;add counts from histo2
    paddq xmm1,xmmword ptr [rdi+rax+16]
    movdq xmmword ptr [rsi+rax],xmm0      ;save final result
    movdq xmmword ptr [rsi+rax+16],xmm1

    add rax,32
    sub ecx,1
    jnz @B
    mov eax,1                             ;set success return code

Done: _DeleteFrame rbx,rsi,rdi
    ret

Error: xor eax,eax                         ;set error return code
    jmp Done

Sse64ImageHistogram_ endp
end

```

The C++ source code for sample program `Sse64ImageHistogram` (Listing 20-1) is almost identical to the code that you studied in Chapter 10. Toward the top of the listing is a function named `Sse64ImageHistogramCpp` that constructs an image histogram using a simple for loop. The function `Sse64ImageHistogram` contains code that loads an 8-bit grayscale test image, invokes the image-histogram processing functions, and compares the results for any discrepancies. It also saves a copy of the histogram pixel counts to a CSV file for subsequent processing or plotting using a spreadsheet program.

The file `Sse64ImageHistogram_.asm` (Listing 20-2) contains a function named `Sse64ImageHistogram_`, which constructs an image histogram using the x86-64 instruction set and SSE4.1. Similar to the earlier histogram sample program in

Chapter 10, this function builds two intermediate histograms and merges them into a final histogram. The `Sse64ImageHistogram_` function starts by creating a stack frame using the `_CreateFrame` macro. Note that the stack frame includes 1024 bytes of local storage, which is used as storage space for one of the intermediate histogram buffers. The caller-provided buffer `histo` is used to store the second intermediate and final histograms. Following the `_EndProlog` macro, function arguments `histo` and `pixel_buff` are validated for proper alignment, and `num_pixels` is validated for proper size. The count values in the two intermediate histogram buffers are then initialized to zero using the `stosq` instruction.

The main processing loop of the `Sse64ImageHistogram_` function is slightly different than its 32-bit counterparts since it uses additional general-purpose registers. At the top of the loop, two `movdqa` instructions load the next block of 32 pixels into registers XMM0/XMM1 and XMM2/XMM3. A `pextrb rax, xmm0, 0` instruction extracts pixel number 0 from XMM0 and copies it to register RAX (the high-order bits of RAX are set to zero). An `add dword ptr [rsi+rax*4], 1` instruction updates the appropriate pixel count entry in the first intermediate histogram. The next two instructions, `pextrb rbx, xmm1, 1` and `add dword ptr [rdi+rbx*4], 1`—process pixel number 1 in the same manner using the second intermediate histogram. This pixel-processing technique is then repeated for the remaining pixels in the current block.

Following completion of the main processing loop, the pixel count values in the two intermediate histograms are summed to create the final image histogram. The `_DeleteFrame` macro is then used to release the local stack frame and restore the previously-saved non-volatile general-purpose registers. Output 20-1 shows the results for sample program `Sse64ImageHistogram`.

Output 20-1. Sample Program `Sse64ImageHistogram`

```
Results for Sse64ImageHistogram()
  Histograms are identical
```

Benchmark times saved to file `__Sse64ImageHistogramTimed.csv`

Table 20-1 contains some benchmark timing measurements for sample program `Sse64ImageHistogram`. The timing measurements shown in this table are essentially the same as those shown in Table 10-1 for the 32-bit version of the image-histogram generation algorithm. This is an expected result since the algorithm used to construct the histogram is access constrained; only one pixel count entry in each intermediate histogram is updated per `add` instruction.

Table 20-1. Mean Execution Times (in Microseconds) for the Histogram Functions in the `Sse64ImageHistogram` Sample Program using `TestImage1.bmp`

CPU	C++	x86-SSE-64
Intel Core i7-4770	300	234
Intel Core i7-4600U	354	278
Intel Core i3-2310M	679	485

Image Conversion

In order to implement certain image-processing algorithms, it is often necessary to convert the pixels of an 8-bit grayscale image from unsigned integer to single-precision floating-point values and vice versa. The sample program in this section illustrates how to do this using the x86-SSE instruction set. Listings 20-3 and 20-4 show the C++ and assembly language source code for sample program `Sse64ImageConvert`.

Listing 20-3. `Sse64ImageConvert.cpp`

```
#include "stdafx.h"
#include "MiscDefs.h"
#include <malloc.h>
#include <stdlib.h>

extern "C" UInt32 NUM_PIXELS_MAX = 16777216;
extern "C" bool ImageUInt8ToFloat_(float* des, const UInt8* src, UInt32↵
num_pixels);
extern "C" bool ImageFloatToUInt8_(UInt8* des, const float* src, UInt32↵
num_pixels);

bool ImageUnit8ToFloatCpp(float* des, const UInt8* src, UInt32 num_pixels)
{
    // Make sure num_pixels is valid
    if ((num_pixels == 0) || (num_pixels > NUM_PIXELS_MAX))
        return false;
    if (num_pixels % 32 != 0)
        return false;

    // Make sure src and des are aligned to a 16-byte boundary
    if (((uintptr_t)src & 0xf) != 0)
        return false;
    if (((uintptr_t)des & 0xf) != 0)
        return false;

    // Convert the image
    for (UInt32 i = 0; i < num_pixels; i++)
        des[i] = src[i] / 255.0f;

    return true;
}

bool ImageFloatToUInt8Cpp(UInt8* des, const float* src, UInt32 num_pixels)
{
    // Make sure num_pixels is valid
    if ((num_pixels == 0) || (num_pixels > NUM_PIXELS_MAX))
        return false;
    if (num_pixels % 32 != 0)
        return false;
```

```

    // Make sure src and des are aligned to a 16-byte boundary
    if (((uintptr_t)src & 0xf) != 0)
        return false;
    if (((uintptr_t)des & 0xf) != 0)
        return false;

    for (UInt32 i = 0; i < num_pixels; i++)
    {
        if (src[i] > 1.0f)
            des[i] = 255;
        else if (src[i] < 0.0)
            des[i] = 0;
        else
            des[i] = (UInt8)(src[i] * 255.0f);
    }

    return true;
}

UInt32 ImageCompareFloat(const float* src1, const float* src2, UInt32
num_pixels)
{
    UInt32 num_diff = 0;
    for (UInt32 i = 0; i < num_pixels; i++)
    {
        if (src1[i] != src2[i])
            num_diff++;
    }
    return num_diff;
}

UInt32 ImageCompareUInt8(const UInt8* src1, const UInt8* src2, UInt32
num_pixels)
{
    UInt32 num_diff = 0;
    for (UInt32 i = 0; i < num_pixels; i++)
    {
        // Pixels values are allowed to differ by 1 to account for
        // slight variations in FP arithmetic
        if (abs((int)src1[i] - (int)src2[i]) > 1)
            num_diff++;
    }
    return num_diff;
}

```

```

void ImageUint8ToFloat(void)
{
    const Uint32 num_pixels = 1024;
    Uint8* src = (Uint8*)_aligned_malloc(num_pixels * sizeof(Uint8), 16);
    float* des1 = (float*)_aligned_malloc(num_pixels * sizeof(float), 16);
    float* des2 = (float*)_aligned_malloc(num_pixels * sizeof(float), 16);

    srand(12);

    for (Uint32 i = 0; i < num_pixels; i++)
        src[i] = (Uint8)(rand() % 256);

    bool rc1 = ImageUnit8ToFloatCpp(des1, src, num_pixels);
    bool rc2 = ImageUint8ToFloat_(des2, src, num_pixels);

    if (!rc1 || !rc2)
    {
        printf("Invalid return code - [%d, %d]\n", rc1, rc2);
        return;
    }

    Uint32 num_diff = ImageCompareFloat(des1, des2, num_pixels);
    printf("\nResults for ImageUint8ToFloat\n");
    printf("  num_diff = %u\n", num_diff);

    _aligned_free(src);
    _aligned_free(des1);
    _aligned_free(des2);
}

void ImageFloatToUint8(void)
{
    const Uint32 num_pixels = 1024;
    float* src = (float*)_aligned_malloc(num_pixels * sizeof(float), 16);
    Uint8* des1 = (Uint8*)_aligned_malloc(num_pixels * sizeof(Uint8), 16);
    Uint8* des2 = (Uint8*)_aligned_malloc(num_pixels * sizeof(Uint8), 16);

    // Initialize the src pixel buffer. The first few entries in src
    // are set to known values for test purposes.
    src[0] = 0.125f;      src[8] = 0.01f;
    src[1] = 0.75f;      src[9] = 0.99f;
    src[2] = -4.0f;      src[10] = 1.1f;
    src[3] = 3.0f;       src[11] = -1.1f;
    src[4] = 0.0f;       src[12] = 0.99999f;
    src[5] = 1.0f;       src[13] = 0.5f;
    src[6] = -0.01f;     src[14] = -0.0;
    src[7] = +1.01f;     src[15] = .333333f;

```

```

srand(20);
for (UInt32 i = 16; i < num_pixels; i++)
    src[i] = (float)rand() / RAND_MAX;

bool rc1 = ImageFloatToUInt8Cpp(des1, src, num_pixels);
bool rc2 = ImageFloatToUInt8_(des2, src, num_pixels);

if (!rc1 || !rc2)
{
    printf("Invalid return code - [%d, %d]\n", rc1, rc2);
    return;
}

UInt32 num_diff = ImageCompareUInt8(des1, des2, num_pixels);
printf("\nResults for ImageFloatToUInt8\n");
printf(" num_diff = %u\n", num_diff);

_aligned_free(src);
_aligned_free(des1);
_aligned_free(des2);
}

int _tmain(int argc, _TCHAR* argv[])
{
    ImageUInt8ToFloat();
    ImageFloatToUInt8();
    return 0;
}

```

Listing 20-4. Sse64ImageConvert_.asm

```

include <MacrosX86-64.inc>
extern NUM_PIXELS_MAX:dword

    .const
; All of these values must be aligned to a 16-byte boundary
UInt8ToFloat      real4 255.0, 255.0, 255.0, 255.0
FloatToUInt8Min   real4 0.0, 0.0, 0.0, 0.0
FloatToUInt8Max   real4 1.0, 1.0, 1.0, 1.0
FloatToUInt8Scale real4 255.0, 255.0, 255.0, 255.0
    .code

; extern "C" bool ImageUInt8ToFloat_(float* des, const UInt8* src, UInt32↵
num_pixels);
;
; Description: The following function converts the values in a UInt8
;              pixel buffer to normalized [0.0, 1.0] SPFP.
;
; Requires:    X86-64, SSE2

```

```

ImageUint8ToFloat_proc frame
    _CreateFrame U2F_,0,64
    _SaveXmmRegs xmm10,xmm11,xmm12,xmm13
    _EndProlog

; Make sure num_pixels is valid and pixel buffers are properly aligned
    test r8d,r8d
    jz Error ;jump if num_pixels
    cmp r8d,[NUM_PIXELS_MAX]
    ja Error ;jump if num_pixels too big
    test r8d,1fh
    jnz Error ;jump if num_pixels % 32 != 0
    test rcx,0fh
    jnz Error ;jump if des not aligned
    test rdx,0fh
    jnz Error ;jump if src not aligned

; Initialize processing loop registers
    shr r8d,5 ;number of pixel blocks
    movaps xmm4,xmmword ptr [Uint8ToFloat] ;xmm4 = packed 255.0f
    pxor xmm5,xmm5 ;xmm5 = packed 0
    align 16

; Load the next block of 32 pixels
@@: movdqa xmm0,xmmword ptr [rdx] ;xmm0 = pixel block
    movdqa xmm10,xmmword ptr [rdx+16] ;xmm10 = pixel block

; Promote the pixel values in xmm0 from unsigned bytes to unsigned dwords
    movdqa xmm2,xmm0
    punpcklbw xmm0,xmm5
    punpckhbw xmm2,xmm5 ;xmm2 & xmm0 = 8 word pixels
    movdqa xmm1,xmm0
    movdqa xmm3,xmm2
    punpcklwd xmm0,xmm5
    punpckhwd xmm1,xmm5
    punpcklwd xmm2,xmm5
    punpckhwd xmm3,xmm5 ;xmm3:xmm0 = 16 dword pixels

; Promote the pixel values in xmm10 from unsigned bytes to unsigned dwords
    movdqa xmm12,xmm10
    punpcklbw xmm10,xmm5
    punpckhbw xmm12,xmm5 ;xmm12 & xmm10 = 8 word pixels
    movdqa xmm11,xmm10
    movdqa xmm13,xmm12
    punpcklwd xmm10,xmm5
    punpckhwd xmm11,xmm5
    punpcklwd xmm12,xmm5
    punpckhwd xmm13,xmm5 ;xmm13:xmm10 = 16 dword pixels

```

```

; Convert pixel values from dwords to SPFP
    cvtdq2ps xmm0,xmm0
    cvtdq2ps xmm1,xmm1
    cvtdq2ps xmm2,xmm2
    cvtdq2ps xmm3,xmm3                ;xmm3:xmm0 = 16 SPFP pixels
    cvtdq2ps xmm10,xmm10
    cvtdq2ps xmm11,xmm11
    cvtdq2ps xmm12,xmm12
    cvtdq2ps xmm13,xmm13            ;xmm13:xmm10 = 16 SPFP pixels

; Normalize all pixel values to [0.0, 1.0] and save the results
    divps xmm0,xmm4
    movaps xmmword ptr [rcx],xmm0    ;save pixels 0 - 3
    divps xmm1,xmm4
    movaps xmmword ptr [rcx+16],xmm1 ;save pixels 4 - 7
    divps xmm2,xmm4
    movaps xmmword ptr [rcx+32],xmm2 ;save pixels 8 - 11
    divps xmm3,xmm4
    movaps xmmword ptr [rcx+48],xmm3 ;save pixels 12 - 15

    divps xmm10,xmm4
    movaps xmmword ptr [rcx+64],xmm10 ;save pixels 16 - 19
    divps xmm11,xmm4
    movaps xmmword ptr [rcx+80],xmm11 ;save pixels 20 - 23
    divps xmm12,xmm4
    movaps xmmword ptr [rcx+96],xmm12 ;save pixels 24 - 27
    divps xmm13,xmm4
    movaps xmmword ptr [rcx+112],xmm13 ;save pixels 28 - 31

    add rdx,32                        ;update src ptr
    add rcx,128                       ;update des ptr
    sub r8d,1
    jnz @B                             ;repeat until done
    mov eax,1                          ;set success return code

Done:  _RestoreXmmRegs xmm10,xmm11,xmm12,xmm13
       _DeleteFrame
       ret

Error: xor eax,eax                    ;set error return code
       jmp done

ImageUint8ToFloat_ endp

; extern "C" bool ImageFloatToUint8_(Uint8* des, const float* src, Uint32*
num_pixels);
;

```

```
; Description: The following function converts a normalized [0.0, 1.0]
;               SPFP pixel buffer to Uint8
;
; Requires      X86-64, SSE4.1
```

```
ImageFloatToUint8_proc frame
    _CreateFrame F2U_,0,32
    _SaveXmmRegs xmm6,xmm7
    _EndProlog
```

```
; Make sure num_pixels is valid and pixel buffers are properly aligned
    test r8d,r8d
    jz Error                ;jump if num_pixels
    cmp r8d,[NUM_PIXELS_MAX]
    ja Error                ;jump if num_pixels too big
    test r8d,1fh
    jnz Error               ;jump if num_pixels % 32 != 0
    test rcx,0fh
    jnz Error               ;jump if des not aligned
    test rdx,0fh
    jnz Error               ;jump if src not aligned
```

```
; Load required packed constants into registers
    movaps xmm5,xmmword ptr [FloatToUint8Scale] ;xmm5 = packed 255.0
    movaps xmm6,xmmword ptr [FloatToUint8Min]   ;xmm6 = packed 0.0
    movaps xmm7,xmmword ptr [FloatToUint8Max]   ;xmm7 = packed 1.0
```

```
LP1:    shr r8d,4                ;number of pixel blocks
        mov r9d,4                ;num pixel quartets per block
```

```
; Convert 16 float pixels to Uint8
```

```
LP2:    movaps xmm0,xmmword ptr [rdx]           ;xmm0 = pixel quartet
        movaps xmm1,xmm0
        cmpltps xmm1,xmm6                       ;compare pixels to 0.0
        andnps xmm1,xmm0                         ;clip pixels < 0.0 to 0.0
        movaps xmm0,xmm1                         ;save result

        cmpnleps xmm1,xmm7                       ;compare pixels to 1.0
        movaps xmm2,xmm1
        andps xmm1,xmm7                          ;clip pixels > 1.0 to 1.0
        andnps xmm2,xmm0                         ;xmm2 = pixels <= 1.0
        orps xmm2,xmm1                           ;xmm2 = final clipped pixels
        mulps xmm2,xmm5                          ;xmm2 = FP pixels [0.0, 255.0]

        cvtps2dq xmm1,xmm2                       ;xmm1 = dword pixels [0, 255]
        packusdw xmm1,xmm1                       ;xmm1[63:0] = word pixels
        packuswb xmm1,xmm1                       ;xmm1[31:0] = bytes pixels
```

```

; Save the current byte pixel quartet
    pextrd eax,xmm1,0           ;eax = new pixel quartet
    psrldq xmm3,4              ;adjust xmm3 for new quartet
    pinsrd xmm3,eax,3          ;xmm3[127:96] = new quartet

    add rdx,16                 ;update src ptr
    sub r9d,1
    jnz LP2                    ;repeat until done

; Save the current byte pixel block (16 pixels)
    movdqa xmmword ptr [rcx],xmm3 ;save current pixel block
    add rcx,16                 ;update des ptr
    sub r8d,1
    jnz LP1                    ;repeat until done
    mov eax,1                  ;set success return code

Done:  _RestoreXmmRegs xmm6,xmm7
       _DeleteFrame
       ret

Error: mov eax,eax            ;set error return code
       jmp Done

ImageFloatToUInt8_ endp
end

```

Toward the top of the file `Sse64ImageConvert.cpp` (Listing 20-3) is a function named `ImageUInt8ToFloatCpp`, which converts all of the pixels in the buffer `src` from `UInt8` [0, 255] to single-precision floating-point [0.0, 1.0]. This function contains a simple for loop that calculates `des[i] = src[i] / 255.0f` for each pixel in `src`. The next function, `ImageFloatToUInt8Cpp`, performs the inverse operation. Note that this function clips any floating-point pixels values greater than 1.0 and less than 0.0. The next two functions—`ImageCompareFloat` and `ImageCompareUInt8`—are used to compare two single-precision floating-point or two `UInt8` pixel buffers for equality following a conversion operation. Note that the latter function allows `UInt8` pixel values to differ by a count of one, which accounts for minor variations in floating-point arithmetic between the C++ and assembly language pixel conversion functions (recall that floating-point arithmetic is not necessarily associative, as explained in Chapter 3).

The `ImageUInt8ToFloat` function sets up a test case that exercises the C++ and assembly language `UInt8` to floating-point conversion functions. A similar function named `ImageFloatToUInt8` tests the corresponding floating-point to `UInt8` conversion routines. Note that this function initializes the first few values of the `src` pixel buffer to known values in order to test the aforementioned pixel clipping requirement. Following each test case conversion operation, the number of detected pixel differences is displayed.

The assembly language conversion function `ImageUnit8ToFloat_` is shown in Listing 20-4. Each iteration of the main processing loop converts 32 pixels from `UInt8` to single-precision floating-point. The pixel conversion technique begins with the promotion of image pixel values from unsigned bytes to unsigned doublewords using a series of x86-SSE `unpack` instructions (`punpcklwb`, `punpckhbw`, `punpcklwd`, and

punpckhwd). The doubleword values are then converted to single-precision floating-point using the `cvtdq2ps` instruction. The resultant floating-point values are then normalized to [0.0, 1.0] and saved to the destination buffer.

Listing 20-4 also contains the assembly language code for the `ImageFloatToUInt8_` function. The inner loop of this conversion function uses the `cmpltps` and `cmpnleps` instructions along with some Boolean logic to clip any floating-point pixel values that are outside the range [0.0, 1.0]. Figure 20-1 illustrates this technique. The clipped floating-point pixel values are then converted to unsigned bytes using the instructions `cvtps2dq`, `packusdw`, and `packuswb`. The resultant byte quartet is then saved in `XMM3[127:96]` using the `pextrd`, `psrldq`, and `pinsrd` instructions. This process is repeated three more times. Following completion of the inner loop, `XMM3` contains 16 converted pixels. This block of pixels is then saved to the destination buffer using a `movdq` instruction. Output 20-2 shows the results for sample program `Sse64ImageConvert`.

Packed constants				
255.0	255.0	255.0	255.0	xmm5
0.0	0.0	0.0	0.0	xmm6
1.0	1.0	1.0	1.0	xmm7
movaps xmm0, xmmword ptr [rdx]				
3.0	-4.0	0.75	0.125	xmm0
movaps xmm1, xmm0				
3.0	-4.0	0.75	0.125	xmm1
cmpltps xmm1, xmm6				
0000000h	FFFFFFFh	0000000h	0000000h	xmm1
andnps xmm1, xmm0				
3.0	0.0	0.75	0.125	xmm1
movaps xmm0, xmm1				
3.0	0.0	0.75	0.125	xmm0
cmpnleps xmm1, xmm7				
FFFFFFFh	0000000h	0000000h	0000000h	xmm1
movaps xmm2, xmm1				
FFFFFFFh	0000000h	0000000h	0000000h	xmm2
andps xmm1, xmm7				
1.0	0.0	0.0	0.0	xmm1
andnps xmm2, xmm0				
0.0	0.0	0.75	0.125	xmm2
orps xmm2, xmm1				
1.0	0.0	0.75	0.125	xmm2
mulps xmm2, xmm5				
255.0	0.0	191.25	31.875	xmm2

Figure 20-1. Illustration of floating-point pixel clipping technique used in function `ImageFloatToUInt8_`

Output 20-2. Sample Program Sse64ImageConvert

```
Results for ImageUint8ToFloat
num_diff = 0
```

```
Results for ImageFloatToUint8
num_diff = 0
```

Vector Arrays

The x86-SSE and x86-AVX instruction sets are often used to accelerate the performance of algorithms that carry out computations using large vector arrays. The sample program of this section, which is named `Sse64VectorArrays`, illustrates how to calculate cross products using vectors stored in an array. It also exemplifies the use of two different data storage methods and their effect on performance. Listings 20-5, 20-6, and 20-7 show the source code for sample program `Sse64VectorArrays`.

Listing 20-5. `Sse64VectorArrays.h`

```
// Simple vector structure
typedef struct
{
    float X;          // Vector X component
    float Y;          // Vector Y component
    float Z;          // Vector Z component
    float Pad;        // Pad for 16 byte structure size
} Vector;

// Vector structure of arrays
typedef struct
{
    float* X;         // Pointer to X components
    float* Y;         // Pointer to Y components
    float* Z;         // Pointer to Z components
} VectorSoA;
```

Listing 20-6. `Sse64VectorArrays.cpp`

```
#include "stdafx.h"
#include "Sse64VectorArrays.h"
#include <stdlib.h>

void Sse64VectorCrossProd(void)
{
    const Uint32 num_vectors = 8;
    const size_t vsize1 = num_vectors * sizeof(Vector);
    const size_t vsize2 = num_vectors * sizeof(float);
```

```

Vector* a1 = (Vector*)_aligned_malloc(vsize1, 16);
Vector* b1 = (Vector*)_aligned_malloc(vsize1, 16);
Vector* c1 = (Vector*)_aligned_malloc(vsize1, 16);
VectorSoA a2, b2, c2;

a2.X = (float*)_aligned_malloc(vsize2, 16);
a2.Y = (float*)_aligned_malloc(vsize2, 16);
a2.Z = (float*)_aligned_malloc(vsize2, 16);
b2.X = (float*)_aligned_malloc(vsize2, 16);
b2.Y = (float*)_aligned_malloc(vsize2, 16);
b2.Z = (float*)_aligned_malloc(vsize2, 16);
c2.X = (float*)_aligned_malloc(vsize2, 16);
c2.Y = (float*)_aligned_malloc(vsize2, 16);
c2.Z = (float*)_aligned_malloc(vsize2, 16);

srand(103);
for (UInt32 i = 0; i < num_vectors; i++)
{
    float a_x = (float)(rand() % 100);
    float a_y = (float)(rand() % 100);
    float a_z = (float)(rand() % 100);
    float b_x = (float)(rand() % 100);
    float b_y = (float)(rand() % 100);
    float b_z = (float)(rand() % 100);

    a1[i].X = a2.X[i] = a_x;
    a1[i].Y = a2.Y[i] = a_y;
    a1[i].Z = a2.Z[i] = a_z;
    b1[i].X = b2.X[i] = b_x;
    b1[i].Y = b2.Y[i] = b_y;
    b1[i].Z = b2.Z[i] = b_z;
    a1[i].Pad = b1[i].Pad = 0;
}

Sse64VectorCrossProd1(c1, a1, b1, num_vectors);
Sse64VectorCrossProd2(&c2, &a2, &b2, num_vectors);

bool error = false;
printf("Results for Sse64VectorCrossProd()\n\n");

for (UInt32 i = 0; i < num_vectors && !error; i++)
{
    const char* fs = "[%8.1f %8.1f %8.1f]\n";
    printf("Vector cross product %d\n", i);
}

```

```

printf(" a1/a2: ");
printf(fs, a1[i].X, a1[i].Y, a1[i].Z);
printf(" b1/b2: ");
printf(fs, b1[i].X, b1[i].Y, b1[i].Z);
printf(" c1: ");
printf(fs, c1[i].X, c1[i].Y, c1[i].Z);
printf(" c2: ");
printf(fs, c2.X[i], c2.Y[i], c2.Z[i]);
printf("\n");

bool error_x = c1[i].X != c2.X[i];
bool error_y = c1[i].Y != c2.Y[i];
bool error_z = c1[i].Z != c2.Z[i];

if (error_x || error_y || error_z)
{
    printf("Compare error at index %d\n", i);
    printf(" %d, %d, %d\n", error_x, error_y, error_z);
    error = true;
}
}

_aligned_free(a1); _aligned_free(b1); _aligned_free(c1);
_aligned_free(a2.X); _aligned_free(a2.Y); _aligned_free(a2.Z);
_aligned_free(b2.X); _aligned_free(b2.Y); _aligned_free(b2.Z);
_aligned_free(c2.X); _aligned_free(c2.Y); _aligned_free(c2.Z);
}

int _tmain(int argc, _TCHAR* argv[])
{
    Sse64VectorCrossProd();
    Sse64VectorCrossProdTimed();
}

```

Listing 20-7. Sse64VectorArrays.asm

```

include <MacrosX86-64.inc>
.code

; This structure must match the VectorSoA structure that's
; defined in Sse64VectorArray.h
VectorSoA struct
X    qword ?    ;pointer to vector X components
Y    qword ?    ;pointer to vector Y components
Z    qword ?    ;pointer to vector Z components
VectorSoA ends

```

```
; extern "C" bool Sse64VectorCrossProd1_(Vector* c, const Vector* a, const
Vector* b, Uint32 num_vectors);
;
; Description: The following function computes the cross product of two
;               3D vectors.
```

```
Sse64VectorCrossProd1_ proc frame
    _CreateFrame Vcp1_,0, 32, r12, r13
    _SaveXmmRegs xmm6,xmm7
    _EndProlog

; Perform required argument validations
    test r9d,r9d
    jz Error                ;jump if num_vectors == 0
    test r9d,3
    jnz Error               ;jump if num_vectors % 4 != 0

    test rcx,0fh
    jnz Error               ;jump if a is misaligned
    test rdx,0fh
    jnz Error               ;jump if b is misaligned
    test r8,0fh
    jnz Error               ;jump if c is misaligned
    xor rax,rax             ;rax = common array offset

    align 16

; Load the next two vectors from a and b
@@:  movaps xmm0,[rdx+rax]   ;a[i]
     movaps xmm1,[r8+rax]   ;b[i]
     movaps xmm2,xmm0
     movaps xmm3,xmm1
     movaps xmm4,[rdx+rax+16] ;a[i+1]
     movaps xmm5,[r8+rax+16] ;b[i+1]
     movaps xmm6,xmm4
     movaps xmm7,xmm5

; Calculate the cross products and save the results (# = don't care)
     shufps xmm0,xmm0,11001001b ;xmm0 = # | ax | az | ay
     shufps xmm1,xmm1,11010010b ;xmm1 = # | by | bx | bz
     mulps  xmm0,xmm1
     shufps xmm2,xmm2,11010010b ;xmm2 = # | ay | ax | az
     shufps xmm3,xmm3,11001001b ;xmm3 = # | bx | bz | by
     mulps  xmm2,xmm3
     subps  xmm0,xmm2        ;xmm0 = # | cz | cy | cx
     movaps [rcx+rax],xmm0  ;save c[i]
```

```

shufps xmm4,xmm4,11001001b      ;xmm4 = # | ax | az | ay
shufps xmm5,xmm5,11010010b     ;xmm5 = # | by | bx | bz
mulps  xmm4,xmm5
shufps xmm6,xmm6,11010010b     ;xmm6 = # | ay | ax | az
shufps xmm7,xmm7,11001001b     ;xmm7 = # | bx | bz | by
mulps  xmm6,xmm7
subps  xmm4,xmm6                ;xmm4 = # | cz | cy | cx
movaps [rcx+rax+16],xmm4        ;save c[i+1]

add rax,32                       ;update array offset
sub r9d,2
jnz @B                            ;repeat until done
mov eax,1                         ;set success return code

```

```

Done:  _RestoreXmmRegs xmm6,xmm7
       _DeleteFrame r12, r13
       ret

```

```

Error: xor eax,eax                ;set error return code
       jmp Done
Sse64VectorCrossProd1_ endp

```

```

; extern "C" bool Sse64VectorCrossProd2_(VectorSoA* c, const VectorSoA* a,
const VectorSoA* b, Uint32 num_vectors);
;
; Description: The following function computes the cross products
;               of the vectors in two VectorSoA instances.

```

```

Sse64VectorCrossProd2_ proc frame
    _CreateFrame Vcp2_,0,32,rbx,rsi,rdi,r12,r13,r14,r15
    _SaveXmmRegs  xmm6,xmm7
    _EndProlog

; Make sure num_vectors is valid
test r9d,r9d
jz Error                ;jump if num_vectors == 0
test r9d,3
jnz Error                ;jump if num_vectors % 4 != 0
shr r9d,2

; Initialize vector component array pointers
xor rax,rax              ;misaligned pointer test value

mov rbx,[rcx+VectorSoA.X] ;rbx = ptr to c.X
or rax,rbx
mov rsi,[rcx+VectorSoA.Y] ;rsi = ptr to c.Y
or rax,rsi

```

```

mov rdi,[rcx+VectorSoA.Z]      ;rdi = ptr to c.Z
or rax,rdi

mov r10,[rdx+VectorSoA.X]     ;r10 = ptr to a.X
or rax,r10
mov r11,[rdx+VectorSoA.Y]     ;r11 = ptr to a.Y
or rax,r11
mov r12,[rdx+VectorSoA.Z]     ;r12 = ptr to a.Z
or rax,r12

mov r13,[r8+VectorSoA.X]      ;r13 = ptr to b.X
or rax,r13
mov r14,[r8+VectorSoA.Y]      ;r14 = ptr to b.Y
or rax,r14
mov r15,[r8+VectorSoA.Z]      ;r15 = ptr to b.C
or rax,r15

and rax,0fh                    ;is a pointer misaligned?
jnz Error                      ;jump if yes

xor rax,rax                    ;rax = common array offset
align 16

; Load the next block of four vectors
@@:  movaps xmm0,xmmword ptr [r10+rax] ;xmm0 = a.X components
     movaps xmm1,xmmword ptr [r11+rax] ;xmm1 = a.Y components
     movaps xmm2,xmmword ptr [r12+rax] ;xmm2 = a.Z components
     movaps xmm6,xmm1
     movaps xmm7,xmm2
     movaps xmm3,xmmword ptr [r13+rax] ;xmm3 = b.X components
     movaps xmm4,xmmword ptr [r14+rax] ;xmm4 = b.Y components
     movaps xmm5,xmmword ptr [r15+rax] ;xmm5 = b.Z components

; Compute four vector cross products
; c.X[i] = a.Y[i] * b.Z[i] - a.Z[i] * b.Y[i]
; c.Y[i] = a.Z[i] * b.X[i] - a.X[i] * b.Z[i]
; c.Z[i] = a.X[i] * b.Y[i] - a.Y[i] * b.X[i]
     mulps xmm6,xmm5           ;xmm6 = a.Y * b.Z
     mulps xmm7,xmm4           ;xmm7 = a.Z * b.Y
     subps xmm6,xmm7           ;xmm6 = c.X components

     mulps xmm2,xmm3           ;xmm2 = a.Z * b.X
     mulps xmm5,xmm0           ;xmm5 = a.X * b.Z
     subps xmm2,xmm5           ;xmm2 = c.Y components

     mulps xmm0,xmm4           ;xmm0 = a.X * b.Y
     mulps xmm1,xmm3           ;xmm1 = a.Y * b.X
     subps xmm0,xmm1           ;xmm0 = c.Z components

```

```

movaps [rdi+rax],xmm0           ;save c.Z
movaps [rsi+rax],xmm2           ;save c.Y
movaps [rbx+rax],xmm6           ;save c.X

add rax,16                       ;update array offset
sub r9d,1
jnz @B                             ;repeat until done
mov eax,1                          ;set success return code

```

```

Done:  _RestoreXmmRegs xmm6,xmm7
       _DeleteFrame rbx,rsi,rdi,r12,r13,r14,r15
       ret

```

```

Error: xor eax,eax                ;set error return code
       jmp Done
Sse64VectorCrossProd2_ endp
       end

```

The cross product of two three-dimensional vectors **a** and **b** is a third vector called **c** that is perpendicular to both **a** and **b**. The *x*, *y*, and *z* components of **c** can be calculated using the following equations:

$$c_x = a_y b_z - a_z b_y \quad c_y = a_z b_x - a_x b_z \quad c_z = a_x b_y - a_y b_x$$

The sample program `Sse64VectorArrays` manages its vector data using two different storage methods. The first technique employs an array of structures (AOS) using a structure named `Vector`, which is declared in the C++ header file `Sse64VectorArrays.h` (Listing 20-5). This structure includes declarations for the vector component values *X*, *Y*, and *Z*. The structure `Vector` also includes an extra `Pad` element that rounds up its size to 16 bytes. The second data storage method uses three separate floating-point arrays to maintain the vector component values. A structure named `VectorSoA`, which is also declared in the C++ header file `Sse64VectorArrays.h`, implements this structure of arrays (SOA) technique. The sample program `Sse64VectorArrays` includes assembly language functions that carry out vector cross product calculations using both AOS and SOA storage techniques in order to exemplify instructional and performance differences between the two approaches.

Listing 20-6 shows the C++ source code for sample program `Sse64VectorArrays`. A function named `Sse64VectorCrossProd` carries out the requisite vector data storage allocations and initializations. It also invokes two assembly language functions that perform cross product calculations using an AOS (`Sse64VectorCrossProd1_`) and a SOA (`Sse64VectorCrossProd2_`). The vector cross product results from both methods are then compared for equality.

The assembly language file `Sse64VectorArrays_.asm` (Listing 20-7) contains two vector cross product calculating functions. The first function, which is named `Sse64VectorCrossProd1_`, computes cross products using arrays of the structure `Vector`. At the top of the main processing loop, vectors `a[i]`, `b[i]`, `a[i+1]` and `b[i+1]` are loaded

into registers XMM0-XMM7. Next, the vector cross product $c[i] = a[i] \times b[i]$ is calculated using a series of `shufps`, `mulps`, and `subps` instructions. Figure 20-2 illustrates this technique in greater detail. This same sequence of instructions is then used to calculate the vector cross product $c[i+1] = a[i+1] \times b[i+1]$. Note that vector calculating instructions ignore the high-order floating-point element of each XMM register (bits 127:96), which means that the processor's SIMD resources are not fully exploited.

Vectors a (xmm0, xmm2) and b (xmm1, xmm3)				
	Z	Y	X	
#	40.0	93.0	74.0	xmm0
#	34.0	80.0	58.0	xmm1
#	40.0	93.0	74.0	xmm2
#	34.0	80.0	58.0	xmm3
shufps xmm0, xmm0, 11001001b				
#	74.0	40.0	93.0	xmm0
shufps xmm1, xmm1, 11010010b				
#	80.0	58.0	34.0	xmm1
mulps xmm0, xmm1				
#	5920.0	2320.0	3162.0	xmm0
shufps xmm2, xmm2, 11010010b				
#	93.0	74.0	40.0	xmm2
shufps xmm3, xmm3, 11001001b				
#	58.0	34.0	80.0	xmm3
mulaps xmm2, xmm3				
#	5394.0	2516.0	3200.0	xmm2
subps xmm0, xmm2				
#	526.0	-196.0	-38.0	xmm0

= Don't Care

Figure 20-2. Vector cross product calculation method used in the `Sse64VectorCrossProd1_` function

The second cross product function `Sse64VectorCrossProd2_` computes its cross products using instances of `VectorSoA`. In this particular example, the application of a SOA to organize the vector component data eliminates the need to perform data shuffle operations. It also facilitates the computation of four vector cross products in parallel. At the top of the main processing loop, the function `Sse64vectorCrossProd2_` loads each

XMM register with four X, Y, or Z components. Calculation of four vector cross products is performed next using six `mulps` and three `subps` instructions, as shown in Figure 20-3. The results are then saved to the VectorSoA buffer named `c`.

xmm0 = a.X, xmm1 = a.Y, xmm2 = a.Z xmm3 = b.X, xmm4 = b.Y, xmm5 = b.Z				
21.0	55.0	68.0	74.0	xmm0
89.0	16.0	88.0	93.0	xmm1/6
25.0	70.0	8.0	40.0	xmm2/7
95.0	72.0	53.0	58.0	xmm3
86.0	86.0	87.0	80.0	xmm4
14.0	39.0	37.0	34.0	xmm5
mulps xmm6, xmm5				
1246.0	624.0	3256.0	3162.0	xmm6
mulps xmm7, xmm4				
2150.0	6020.0	696.0	3200.0	xmm7
subps xmm6, xmm7 ;xmm6 = c.X components (4 vectors)				
-904.0	-5396.0	2560.0	-38.0	xmm6
mulps xmm2, xmm3				
2375.0	5040.0	424.0	2320.0	xmm2
mulps xmm5, xmm0				
294.0	2145.0	2516.0	2516.0	xmm5
subps xmm2, xmm5 ;xmm2 = c.Y components (4 vectors)				
2081.0	2895.0	-2092.0	-196.0	xmm2
mulps xmm0, xmm4				
1806.0	4730.0	5916.0	5920.0	xmm0
mulps xmm1, xmm3				
8455.0	1152.0	4664.0	5394.0	xmm1
subps xmm0, xmm1 ;xmm0 = c.Z components (4 vectors)				
-6649.0	3578.0	1252.0	526.0	xmm0

Figure 20-3. Vector cross product calculation method used in the `Sse64VectorCrossProd2_` function

Output 20-3 shows the results for sample program `Sse64VectorArrays`. Table 20-2 shows some timing measurements for the vector cross product functions `Sse64VectorCrossProd1_` and `Sse64VectorCrossProd2_`. For this sample program, the SOA approach is noticeably faster than the AOS technique.

Output 20-3. Sample Program `Sse64VectorArrays`

Results for `Sse64VectorCrossProd()`

Vector cross product 0

```
a1/a2: [ 74.0  93.0  40.0]
b1/b2: [ 58.0  80.0  34.0]
c1:    [ -38.0 -196.0 526.0]
c2:    [ -38.0 -196.0 526.0]
```

Vector cross product 1

```
a1/a2: [ 68.0  88.0   8.0]
b1/b2: [ 53.0  87.0  37.0]
c1:    [2560.0 -2092.0 1252.0]
c2:    [2560.0 -2092.0 1252.0]
```

Vector cross product 2

```
a1/a2: [ 55.0  16.0  70.0]
b1/b2: [ 72.0  86.0  39.0]
c1:    [-5396.0 2895.0 3578.0]
c2:    [-5396.0 2895.0 3578.0]
```

Vector cross product 3

```
a1/a2: [ 21.0  89.0  25.0]
b1/b2: [ 95.0  86.0  14.0]
c1:    [-904.0 2081.0 -6649.0]
c2:    [-904.0 2081.0 -6649.0]
```

Vector cross product 4

```
a1/a2: [ 36.0  65.0   5.0]
b1/b2: [ 68.0  92.0  20.0]
c1:    [ 840.0 -380.0 -1108.0]
c2:    [ 840.0 -380.0 -1108.0]
```

Vector cross product 5

```
a1/a2: [ 31.0  86.0  13.0]
b1/b2: [ 47.0  97.0  94.0]
c1:    [6823.0 -2303.0 -1035.0]
c2:    [6823.0 -2303.0 -1035.0]
```

Vector cross product 6

```
a1/a2: [ 78.0 58.0 43.0]
b1/b2: [ 47.0 48.0 42.0]
c1:    [ 372.0 -1255.0 1018.0]
c2:    [ 372.0 -1255.0 1018.0]
```

Vector cross product 7

```
a1/a2: [ 23.0 64.0 86.0]
b1/b2: [ 10.0 42.0 71.0]
c1:    [ 932.0 -773.0 326.0]
c2:    [ 932.0 -773.0 326.0]
```

Benchmark times saved to file `__Sse64VectorCrossProdTimed.csv`

Table 20-2. Mean Execution Times (in Microseconds) for Vector Cross Product Functions in Sample Program `Sse64VectorArrays` (`num_vectors = 50,000`)

CPU	Sse64VectorCrossProd1_ (SOA)	Sse64VectorCrossProd2_ (AOS)
Intel Core i7-4770	67	50
Intel Core i7-4600U	106	74
Intel Core i3-2310M	165	126

X86-AVX-64 Programming

The sample code in this section demonstrates how to exploit the computational resources of x86-AVX in a 64-bit assembly language function. This includes the scalar floating-point, packed integer, and packed floating-point instructions of x86-AVX. The sample code also exemplifies use of C++ library functions and additional macro-processing techniques.

Ellipsoid Calculations

This section examines a sample program that calculates the volume and surface area of an ellipsoid using the scalar floating-point capabilities of x86-AVX. It also illustrates how to call a standard C++ library function from a 64-bit function that uses x86-AVX instructions. Listings 20-8 and 20-9 show the C++ and assembly language source code for sample program `Avx64CalcEllipsoid`.

Listing 20-8. `Avx64CalcEllipsoid.cpp`

```
#include "stdafx.h"
#define _USE_MATH_DEFINES
#include <math.h>

extern "C" bool Avx64CalcEllipsoid_(const double* a, const double* b, const double* c, int n, double p, double* sa, double* vol);
```

```

bool Avx64CalcEllipsoidCpp(const double* a, const double* b, const double* c,
int n, double p, double* sa, double* vol)
{
    if (n <= 0)
        return false;

    for (int i = 0; i < n; i++)
    {
        double a_p = pow(a[i], p);
        double b_p = pow(b[i], p);
        double c_p = pow(c[i], p);

        double temp1 = (a_p * b_p + a_p * c_p + b_p * c_p) / 3;

        sa[i] = 4 * M_PI * pow(temp1, 1.0 / p);
        vol[i] = 4 * M_PI * a[i] * b[i] * c[i] / 3;
    }

    return true;
}

int _tmain(int argc, _TCHAR* argv[])
{
    const int n = 8;
    const double p = 1.6075;
    const double a[n] = { 1, 2, 6, 3, 4, 5, 5, 2};
    const double b[n] = { 1, 2, 1, 7, 2, 6, 5, 7};
    const double c[n] = { 1, 2, 7, 4, 3, 11, 5, 9};
    double sa1[n], vol1[n];
    double sa2[n], vol2[n];

    Avx64CalcEllipsoidCpp(a, b, c, n, p, sa1, vol1);
    Avx64CalcEllipsoid_(a, b, c, n, p, sa2, vol2);

    printf("Results for Avx64CalcEllipsoid\n\n");

    for (int i = 0; i < n; i++)
    {
        printf("\na, b, c: %6.2lf %6.2lf %6.2lf\n", a[i], b[i], c[i]);
        printf(" sa1, vol1: %14.8lf %14.8lf\n", sa1[i], vol1[i]);
        printf(" sa2, vol2: %14.8lf %14.8lf\n", sa2[i], vol2[i]);
    }

    return 0;
}

```

Listing 20-9. Avx64CalcEllipsoid_.asm

```

        include <MacrosX86-64.inc>
        extern pow:proc

        .const
r8_1p0  real8 1.0
r8_3p0  real8 3.0
r8_4p0  real8 4.0
r8_pi   real8 3.14159265358979323846
        .code

; extern "C" bool Avx64CalcEllipsoid_(const double* a, const double* b, ←
const double* c, int n, double p, double* sa, double* vol);
;
; Description: The following function calculates the surface area
;              and volume of an ellipsoid
;
; Requires:    x86-64, AVX

Avx64CalcEllipsoid_ proc frame
    _CreateFrame Ce_,0,144,rbx,rsi,rdi,r12,r13,r14,r15
    _SaveXmmRegs xmm6,xmm7,xmm8,xmm9,xmm10,xmm12,xmm13,xmm14,xmm15
    _EndProlog

; Perform required register initializations. Note that non-volatile
; registers are used since this function calls the function pow().
    test r9d,r9d                ;is n <= 0?
    jle Error                   ;jump if yes
    mov r12,rcx                 ;r12 = a ptr
    mov r13,rdx                 ;r13 = b ptr
    mov r14,r8                  ;r14 = c ptr
    mov r15d,r9d                ;r15 = n

    vmovsd xmm12,real8 ptr [rbp+Ce_OffsetStackArgs] ;xmm12 = p
    vmovsd xmm0,real8 ptr [r8_1p0]
    vdivsd xmm13,xmm0,xmm12     ;xmm13 = 1 / p
    vmovsd xmm1,real8 ptr [r8_4p0]
    vmulsd xmm14,xmm1,[r8_pi]   ;xmm14 = 4 * pi
    vmovsd xmm15,[r8_3p0]      ;xmm15 = 3

    mov rsi,[rbp+Ce_OffsetStackArgs+8] ;rsi = sa ptr
    mov rdi,[rbp+Ce_OffsetStackArgs+16] ;rdi = vol ptr
    xor rbx,rbx                 ;rbx = common array offset
    sub rsp,32                  ;allocate home area for pow()

@@:    vmovsd xmm6,real8 ptr [r12+rbx] ;xmm6 = a
        vmovsd xmm7,real8 ptr [r13+rbx] ;xmm7 = b
        vmovsd xmm8,real8 ptr [r14+rbx] ;xmm8 = c

```

```

; Calculate the ellipsoid's volume
vmulsd xmm0,xmm14,xmm6           ;xmm0 = 4 * pi * a
vmulsd xmm1,xmm7,xmm8           ;xmm1 = b * c;
vmulsd xmm0,xmm0,xmm1           ;xmm0 = 4 * pi * a * b * c
vdivsd xmm0,xmm0,xmm15          ;xmm0 = 4 * pi * a * b * c / 3
vmovsd real8 ptr [rdi+rbx],xmm0 ;save ellipsoid volume

; Calculate the ellipsoid's surface area (see text for equation)
vmovsd xmm0,xmm0,xmm6           ;xmm0 = a
vmovsd xmm1,xmm1,xmm12          ;xmm1 = p
call pow
vmovsd xmm9,xmm9,xmm0           ;xmm9 = pow(a,p)

vmovsd xmm0,xmm0,xmm7           ;xmm0 = b
vmovsd xmm1,xmm1,xmm12          ;xmm1 = p
call pow
vmovsd xmm10,xmm10,xmm0         ;xmm10 = pow(b,p)

vmovsd xmm0,xmm0,xmm8           ;xmm0 = c
vmovsd xmm1,xmm1,xmm12          ;xmm1 = p
call pow
vmovsd xmm0,xmm0,xmm12          ;xmm0 = pow(c,p)

vmulsd xmm1,xmm9,xmm10          ;xmm1 = pow(a,p) * pow(b,p)
vmulsd xmm2,xmm9,xmm0           ;xmm2 = pow(a,p) * pow(c,p)
vmulsd xmm3,xmm10,xmm0          ;xmm3 = pow(b,p) * pow(c,p)

vaddsd xmm0,xmm1,xmm2
vaddsd xmm0,xmm0,xmm3
vdivsd xmm0,xmm0,xmm15          ;xmm0 = bracket sub expression
vmovsd xmm1,xmm1,xmm13          ;xmm1 = 1 / p
call pow
vmovsd xmm0,xmm0,xmm14          ;xmm0 = pow(subexpr,1/p)
vmulsd xmm0,xmm0,xmm14          ;xmm0 = final surface area
vmovsd real8 ptr [rsi+rbx],xmm0 ;save surface area

; Update the counter and offset value, repeat if not finished
add rbx,8
sub r15,1
jnz @B
mov eax,1                       ;set success return code

Done: _RestoreXmmRegs xmm6,xmm7,xmm8,xmm9,xmm10,xmm12,xmm13,xmm14,xmm15
_DeleteFrame rbx,rsi,rdi,r12,r13,r14,r15
ret

Error: xor eax,eax               ;set error return code
jmp done
Avx64CalcEllipsoid_ endp
end

```

An ellipsoid is a three-dimensional solid figure whose plane cross sections are ellipses. The size of an ellipsoid is determined by the lengths of its three semi-axes a , b , and c . The internal volume of an ellipsoid is easily computed using these lengths. Precise calculation of an ellipsoid's surface area, however, requires multipart calculations using elliptic integrals. Fortunately, the much simpler *Knud Thomsen* approximation (see Appendix C for references) is an acceptable alternative for many applications. Here are the equations that sample program `Avx64CalcEllipsoid` uses to calculate the volume and surface area of an ellipsoid:

$$V = \frac{4}{3}\pi abc \quad SA = 4\pi \left[\frac{1}{3}(a^p b^p + a^p c^p + b^p c^p) \right]^{1/p} \quad p \approx 1.6075$$

The C++ file for sample program `Avx64CalcEllipsoid` (Listing 20-8) contains two straightforward functions. The first function, named `Avx64CalcEllipsoidCpp`, calculates the volumes and surface areas of the ellipsoids specified by the semi-axis arrays a , b , and c . The other function, `_tmain`, includes code that initializes test cases for the C++ function `Avx64CalcEllipsoidCpp` and the corresponding assembly language function `Avx64CalcEllipsoid_`.

Listing 20-9 shows the assembly language source code for the function `Avx64CalcEllipsoid_`. Immediately following the function prolog, argument values a , b , c , and n are copied to registers R12-R15, respectively. These registers are used since their values are preserved by the C++ library function `pow`. The next block of instructions loads the necessary double-precision floating-point constant values into registers XMM12-XMM15. Several miscellaneous initializations are then performed, including result array pointer registers and allocation of the stack home area for the function `pow`.

The main processing loop starts by loading semi-axis values $a[i]$, $b[i]$, and $c[i]$ into registers XMM6-XMM8, respectively. The function then calculates the volume of the ellipsoid using the `vmulsd` and `vddivsd` instructions. The ellipsoid's surface area is calculated next using the previously defined approximation equation. Note that the required argument values are copied to registers XMM0 and XMM1 prior to each call `pow` instruction. Also note that the function `Avx64CalcEllipsoid_` saves the return value from `pow` in a non-volatile register prior to the next call. Output 20-4 shows the results for sample program `Avx64CalcEllipsoid`.

Output 20-4. Sample Program `Avx64CalcEllipsoid`

Results for `Avx64CalcEllipsoid`

```
a, b, c:  1.00  1.00  1.00
sa1, vol1: 12.56637061  4.18879020
sa2, vol2: 12.56637061  4.18879020

a, b, c:  2.00  2.00  2.00
sa1, vol1: 50.26548246  33.51032164
sa2, vol2: 50.26548246  33.51032164
```



```

a, b, c:  6.00  1.00  7.00
sa1, vol1: 282.73569300 175.92918860
sa2, vol2: 282.73569300 175.92918860

a, b, c:  3.00  7.00  4.00
sa1, vol1: 263.60352668 351.85837720
sa2, vol2: 263.60352668 351.85837720

a, b, c:  4.00  2.00  3.00
sa1, vol1: 111.60403108 100.53096491
sa2, vol2: 111.60403108 100.53096491

a, b, c:  5.00  6.00 11.00
sa1, vol1: 649.98183211 1382.30076758
sa2, vol2: 649.98183211 1382.30076758

a, b, c:  5.00  5.00  5.00
sa1, vol1: 314.15926536 523.59877560
sa2, vol2: 314.15926536 523.59877560

a, b, c:  2.00  7.00  9.00
sa1, vol1: 452.93733288 527.78756580
sa2, vol2: 452.93733288 527.78756580

```

RGB Image Processing

The next sample program is called `Avx64CalcRgbMinMax`, and it illustrates how to calculate the minimum and maximum red, green, and blue pixel values of an RGB image. It also demonstrates use of some additional macro processing techniques. The C++ and assembly language source code for sample program `Avx64CalcRgbMinMax` are shown in Listings 20-10 and 20-11.

Listing 20-10. `Avx64CalcRgbMinMax.cpp`

```

#include "stdafx.h"
#include "MiscDefs.h"
#include <stdlib.h>
#include <malloc.h>

extern "C" bool Avx64CalcRgbMinMax_(UInt8* rgb[3], UInt32 num_pixels, UInt8*
min_vals[3], UInt8 max_vals[3]);

bool Avx64CalcRgbMinMaxCpp(UInt8* rgb[3], UInt32 num_pixels, UInt8*
min_vals[3], UInt8 max_vals[3])
{
    // Make sure num_pixels is valid
    if ((num_pixels == 0) || (num_pixels % 32 != 0))
        return false;

```

```

// Make sure the color planes are properly aligned
for (UInt32 i = 0; i < 3; i++)
{
    if (((uintptr_t)rgb[i] & 0x1f) != 0)
        return false;
}

// Find the min and max of each color plane
for (UInt32 i = 0; i < 3; i++)
{
    min_vals[i] = 255;    max_vals[i] = 0;

    for (UInt32 j = 0; j < num_pixels; j++)
    {
        if (rgb[i][j] < min_vals[i])
            min_vals[i] = rgb[i][j];
        else if (rgb[i][j] > max_vals[i])
            max_vals[i] = rgb[i][j];
    }
}

return true;
}

int _tmain(int argc, _TCHAR* argv[])
{
    const UInt32 n = 1024;
    UInt8* rgb[3];

    rgb[0] = (UInt8*)_aligned_malloc(n * sizeof(UInt8), 32);
    rgb[1] = (UInt8*)_aligned_malloc(n * sizeof(UInt8), 32);
    rgb[2] = (UInt8*)_aligned_malloc(n * sizeof(UInt8), 32);

    for (UInt32 i = 0; i < n; i++)
    {
        rgb[0][i] = 5 + rand() % 245;
        rgb[1][i] = 5 + rand() % 245;
        rgb[2][i] = 5 + rand() % 245;
    }

    // Initialize known min & max values for validation purposes
    rgb[0][n / 4] = 4;   rgb[1][n / 2] = 1;   rgb[2][3 * n / 4] = 3;
    rgb[0][n / 3] = 254; rgb[1][2 * n / 5] = 251; rgb[2][n - 1] = 252;

    UInt8 min_vals1[3], max_vals1[3];
    UInt8 min_vals2[3], max_vals2[3];

```

```

Avx64CalcRgbMinMaxCpp(rgb, n, min_vals1, max_vals1);
Avx64CalcRgbMinMax_(rgb, n, min_vals2, max_vals2);

printf("Results for Avx64CalcRgbMinMax\n\n");
printf("          R  G  B\n");
printf("-----\n");
printf("min_vals1: %3d %3d %3d\n", min_vals1[0], min_vals1[1],
min_vals1[2]);
printf("min_vals2: %3d %3d %3d\n", min_vals2[0], min_vals2[1],
min_vals2[2]);
printf("\n");
printf("max_vals1: %3d %3d %3d\n", max_vals1[0], max_vals1[1],
max_vals1[2]);
printf("max_vals2: %3d %3d %3d\n", max_vals2[0], max_vals2[1],
max_vals2[2]);

    _aligned_free(rgb[0]);
    _aligned_free(rgb[1]);
    _aligned_free(rgb[2]);
return 0;
}

```

Listing 20-11. Avx64CalcRgbMinMax_.asm

```

include <MacrosX86-64.inc>

; 256-bit wide constants
ConstVals segment readonly align(32)
InitialPminVal db 32 dup(0ffh)
InitialPmaxVal db 32 dup(00h)
ConstVals ends
    .code

; Macro _YmmVpextrMinub
;
; Description: The following macro generates code that extracts the
;               smallest unsigned byte value from register YmmSrc.

_YmmVpextrMinub macro GprDes, YmmSrc, YmmTmp

; Make sure YmmSrc and YmmTmp are different
.erridni <YmmSrc>, <YmmTmp>, <Invalid registers>

; Construct text strings for the corresponding XMM registers
    YmmSrcSuffix SUBSTR <YmmSrc>, 2
    XmmSrc CATSTR <X>, YmmSrcSuffix

```

```
YmmTmpSuffix SUBSTR <YmmTmp>,2
XmmTmp CATSTR <X>,YmmTmpSuffix
```

```
; Reduce the 32 byte values in YmmSrc to the smallest value
vextracti128 XmmTmp,YmmSrc,1
vpmiub XmmSrc,XmmSrc,XmmTmp ;XmmSrc = final 16 min values

vpsrldq XmmTmp,XmmSrc,8
vpmiub XmmSrc,XmmSrc,XmmTmp ;XmmSrc = final 8 min values

vpsrldq XmmTmp,XmmSrc,4
vpmiub XmmSrc,XmmSrc,XmmTmp ;XmmSrc = final 4 min values

vpsrldq XmmTmp,XmmSrc,2
vpmiub XmmSrc,XmmSrc,XmmTmp ;XmmSrc = final 2 min values

vpsrldq XmmTmp,XmmSrc,1
vpmiub XmmSrc,XmmSrc,XmmTmp ;XmmSrc = final 1 min value

vpextrb GprDes,XmmSrc,0 ;mov final min value to Gpr
endm
```

```
; Macro _YmmVpextrMaxub
```

```
;
```

```
; Description: The following macro generates code that extracts the
; largest unsigned byte value from register YmmSrc.
```

```
_YmmVpextrMaxub macro GprDes,YmmSrc,YmmTmp
```

```
; Make sure YmmSrc and YmmTmp are different
.erridni <YmmSrc>, <YmmTmp>, <Invalid registers>
```

```
; Construct text strings for the corresponding XMM registers
```

```
YmmSrcSuffix SUBSTR <YmmSrc>,2
XmmSrc CATSTR <X>,YmmSrcSuffix
```

```
YmmTmpSuffix SUBSTR <YmmTmp>,2
XmmTmp CATSTR <X>,YmmTmpSuffix
```

```
; Reduce the 32 byte values in YmmSrc to the largest value
vextracti128 XmmTmp,YmmSrc,1
vpmiub XmmSrc,XmmSrc,XmmTmp ;XmmSrc = final 16 max values

vpsrldq XmmTmp,XmmSrc,8
vpmiub XmmSrc,XmmSrc,XmmTmp ;XmmSrc = final 8 max values

vpsrldq XmmTmp,XmmSrc,4
vpmiub XmmSrc,XmmSrc,XmmTmp ;XmmSrc = final 4 max values
```

```

vpsrldq XmmTmp,XmmSrc,2
vpmmaxub XmmSrc,XmmSrc,XmmTmp           ;XmmSrc = final 2 max values

vpsrldq XmmTmp,XmmSrc,1
vpmmaxub XmmSrc,XmmSrc,XmmTmp           ;XmmSrc = final 1 max value

vpextrb GprDes,XmmSrc,0                 ;mov final max value to Gpr
endm

; extern "C" bool Avx64CalcRgbMinMax_(UInt8* rgb[3], UInt32 num_pixels,
; UInt8 min_vals[3], UInt8 max_vals[3]);
;
; Description: The following function determines the minimum and maximum
; pixel values of each color plane array.
;
; Requires: x86-64, AVX2

Avx64CalcRgbMinMax_ proc frame
    _CreateFrame CalcMinMax_,0,48,r12
    _SaveXmmRegs xmm6,xmm7,xmm8
    _EndProlog

; Make sure num_pixels and the color plane arrays are valid
test edx,edx
jz Error                               ;jump if num_pixels == 0
test edx,01fh
jnz Error                               ;jump if num_pixels % 32 != 0

xor rax,rax
mov r10,[rcx]                           ;r10 = R color plane ptr
or rax,r10
mov r11,[rcx+8]                          ;r11 = G color plane ptr
or rax,r11
mov r12,[rcx+16]                         ;r12 = B color plane ptr
or rax,r12
test rax,1fh
jnz Error                               ;jump if R, G, or B misaligned

; Initialize the processing loop registers
shr edx,5                                ;edx = number of pixel blocks
xor rcx,rcx                              ;rcx = common array offset

vmovdqa ymm3,ymmword ptr [InitialPminVal] ;ymm3 = R minimums
vmovdqa ymm4,ymm3                        ;ymm4 = G minimums
vmovdqa ymm5,ymm3                        ;ymm5 = B minimums

```

```

    vmovdqa ymm6,ymmword ptr [InitialPmaxVal]    ;ymm6 = R maximums
    vmovdqa ymm7,ymm6                            ;ymm7 = G maximums
    vmovdqa ymm8,ymm6                            ;ymm8 = B maximums

; Scan RGB color plane arrays for packed minimums and maximums
@@:  vmovdqa ymm0,ymmword ptr [r10+rcx]    ;ymm0 = R pixels
     vmovdqa ymm1,ymmword ptr [r11+rcx]    ;ymm1 = G pixels
     vmovdqa ymm2,ymmword ptr [r12+rcx]    ;ymm2 = B pixels

     vpmiub ymm3,ymm3,ymm0                  ;update R minimums
     vpmiub ymm4,ymm4,ymm1                  ;update G minimums
     vpmiub ymm5,ymm5,ymm2                  ;update B minimums

     vpmasub ymm6,ymm6,ymm0                 ;update R maximums
     vpmasub ymm7,ymm7,ymm1                 ;update G maximums
     vpmasub ymm8,ymm8,ymm2                 ;update B maximums

     add rcx,32
     sub edx,1
     jnz @B

; Calculate the final RGB minimum values
    _YmmVpextrMinub rax,ymm3,ymm0
    mov byte ptr [r8],al                    ;save min R
    _YmmVpextrMinub rax,ymm4,ymm0
    mov byte ptr [r8+1],al                  ;save min G
    _YmmVpextrMinub rax,ymm5,ymm0
    mov byte ptr [r8+2],al                  ;save min B

; Calculate the final RGB maximum values
    _YmmVpextrMaxub rax,ymm6,ymm1
    mov byte ptr [r9],al                    ;save max R
    _YmmVpextrMaxub rax,ymm7,ymm1
    mov byte ptr [r9+1],al                  ;save max G
    _YmmVpextrMaxub rax,ymm8,ymm1
    mov byte ptr [r9+2],al                  ;save max B

    mov eax,1                               ;set success return code
    vzeroupper

Done:  _RestoreXmmRegs xmm6,xmm7,xmm8
       _DeleteFrame r12
       ret

Error: xor eax,eax                           ;set error return code
       jmp Done
Avx64CalcRgbMinMax_ endp
       end

```

Near the top of the C++ file `Avx64CalcRgbMinMax.cpp` (Listing 20-10) is a function named `Avx64CalcRgbMinMaxCpp`. This function contains a simple for loop that determines the minimum and maximum RGB values of the input color plane arrays. The C++ file additionally includes the function `_tmain`, which contains code that initializes the color plane arrays for test purposes. This function also invokes the C++ and assembly language RGB min-max functions and displays the results.

Listing 20-11 shows the source code for the assembly language file `Avx64CalcRgbMinMax_.asm`. Immediately following the `ConstVals` segment are two macro definitions: `_YmmVpextrMinub` and `_YmmVpextrMaxub`. These macros generate code that extracts the smallest or largest unsigned byte value from a YMM register. The source code statements of both macros are the same, except for use of the `vpmiub` or `vpmaxub` instructions. The ensuing paragraphs explain the statements and logic of the `_YmmVpextrMinub` macro in greater detail.

The `_YmmVpextrMinub` macro requires three parameters: a destination general-purpose register (`GprDes`), a source YMM register (`YmmSrc`), and a temporary YMM register (`YmmTmp`). Note that `YmmSrc` and `YmmTmp` must be different registers. If they're the same, the `.erridni` directive (Error if Text Items are Identical, Case Insensitive) produces an error during assembly.

In order to generate the correct assembly language code, the macro `_YmmVpextrMinub` requires an XMM register text string (`XmmSrc`) that corresponds to the low-order portion of the specified `YmmSrc` register. For example, if `YmmSrc` equals "YMM0", the macro text string `XmmSrc` equals "XMM0". The macro directives `substr` (Return Substring of Text Item) and `catstr` (Concatenate Text Items) are used to initialize `XmmSrc`. The statement `YmmSrcSuffix SUBSTR <YmmSrc>,2` assigns a text string value to `YmmSrcSuffix` that excludes the leading character of macro parameter `YmmSrc`. The next statement, `XmmSrc CATSTR <X>,YmmSrcSuffix`, adds a leading "X" to the value of `YmmSrcSuffix` and assigns it to `XmmSrc`. The same set of directives is then used to assign a text string value to `XmmTmp`.

Following initialization of the required macro text strings are the instructions that extract the smallest byte value from the specified YMM register. The `vextracti128 XmmTmp,YmmSrc,1` instruction copies the upper 16 bytes of register `YmmSrc` to `XmmTmp`. A `vpmiub XmmSrc,XmmSrc,XmmTmp` instruction loads the final 16 minimum values into `XmmSrc`. The `vpsrldq XmmTmp,XmmSrc,8` instruction shifts a copy of the value that's in `XmmSrc` to the right by eight bytes and saves the result to `XmmTmp`. This facilitates the use of another `vpmiub` instruction that reduces the number of minimum byte values from 16 to 8. Repeated sets of the `vpsrldq` and `vpmiub` instructions are then employed until the final minimum value resides in the low-order byte of `XmmSrc`. A `vpxtrb GprDes,XmmSrc,0` instruction copies the final minimum value to the specified general-purpose register.

The function `Avx64CalcRgbMinMax_` uses registers YMM3-YMM5 and YMM6-YMM8 to maintain the RGB minimum and maximum values, respectively. During each iteration of the main processing loop, a series of `vpmiub` and `vpmaxub` instructions update the current RGB minimums and maximums. Upon completion of the main processing loop, the aforementioned YMM registers contain the final 32 RGB minimum and maximum pixel values. The `_YmmVpextrMinub` and `_YmmVpextrMaxub` macros are then exploited to extract the final RGB minimum and maximum pixel values. These values are then saved to the specified results array.

Use of the YMM registers by function `Avx64CalcRgbMinMax_` means that a `vzeroupper` is required *before* any epilog code, which begins with the macro statement `_RestoreXmmRegs`. It should be noted that using the alternative `vzeroall` instruction prior to the epilog doesn't make sense since 64-bit functions must preserve the contents of registers XMM6-XMM15. The `vzeroall` instruction can still be used within the body of a 64-bit function provided the contents of the non-volatile XMM registers are preserved. Output 20-5 shows the results for sample program `Avx64CalcRgbMinMax`.

Output 20-5. Sample Program `Avx64CalcRgbMinMax`

Results for `Avx64CalcRgbMinMax`

```

                R   G   B
-----
min_vals1:    4   1   3
min_vals2:    4   1   3

max_vals1:   254 251 252
max_vals2:   254 251 252

```

Matrix Inverse

In Chapter 9, you learned how to accelerate the multiplication of two single-precision floating-point 4×4 matrices using the x86-SSE instruction set. In this section, you study a program that calculates the inverse of a 4×4 single-precision floating-point matrix using 64-bit x86-AVX. Listings 20-12 and 20-13 show the C++ and assembly languages source code for sample program `Avx64CalcMat4x4Inv`.

Listing 20-12. `Avx64CalcMat4x4Inv.cpp`

```

#include "stdafx.h"
#include <math.h>
#include "Avx64CalcMat4x4Inv.h"

// #define MAT_INV_DEBUG    // Remove comment to enable extra printf's

bool Mat4x4InvCpp(Mat4x4 m_inv, Mat4x4 m, float epsilon, bool* is_singular)
{
    __declspec(align(32)) Mat4x4 m2;
    __declspec(align(32)) Mat4x4 m3;
    __declspec(align(32)) Mat4x4 m4;
    float t1, t2, t3, t4;
    float c1, c2, c3, c4;

```



```

// Make sure matrices are properly aligned
if (((uintptr_t)m_inv & 0x1f) != 0)
    return false;
if (((uintptr_t)m & 0x1f) != 0)
    return false;

// Calculate the required matrix trace values
Mat4x4Mul(m2, m, m);
Mat4x4Mul(m3, m2, m);
Mat4x4Mul(m4, m3, m);
t1 = Mat4x4Trace(m);
t2 = Mat4x4Trace(m2);
t3 = Mat4x4Trace(m3);
t4 = Mat4x4Trace(m4);

#ifdef MAT_INV_DEBUG
    printf("t1: %16e\n", t1);
    printf("t2: %16e\n", t2);
    printf("t3: %16e\n", t3);
    printf("t4: %16e\n", t4);
#endif

c1 = -t1;
c2 = -1.0f / 2.0f * (c1 * t1 + t2);
c3 = -1.0f / 3.0f * (c2 * t1 + c1 * t2 + t3);
c4 = -1.0f / 4.0f * (c3 * t1 + c2 * t2 + c1 * t3 + t4);

#ifdef MAT_INV_DEBUG
    printf("c1: %16e\n", c1);
    printf("c2: %16e\n", c2);
    printf("c3: %16e\n", c3);
    printf("c4: %16e\n", c4);
#endif

// Make sure matrix is not singular
if ((*is_singular = (fabs(c4) < epsilon)) != false)
    return false;

// Calculate = -1.0 / c4 * (m3 + c1 * m2 + c2 * m + c3 * I)
__declspec(align(32)) Mat4x4 I;
__declspec(align(32)) Mat4x4 tempA, tempB, tempC, tempD;

Mat4x4SetI(I);
Mat4x4MulScalar(tempA, I, c3);
Mat4x4MulScalar(tempB, m, c2);
Mat4x4MulScalar(tempC, m2, c1);

```

```

    Mat4x4Add(tempD, tempA, tempB);
    Mat4x4Add(tempD, tempD, tempC);
    Mat4x4Add(tempD, tempD, m3);
    Mat4x4MulScalar(m_inv, tempD, -1.0f / c4);
    return true;
}

void Avx64Mat4x4Inv(Mat4x4 m, const char* s)
{
    Mat4x4Printf(m, s);

    for (int i = 0; i <= 1; i++)
    {
        const float epsilon = 1.0e-9f;
        __declspec(align(32)) Mat4x4 m_inv;
        __declspec(align(32)) Mat4x4 m_ver;
        bool rc, is_singular;

        if (i == 0)
        {
            printf("\nCalculating inverse matrix - Mat4x4InvCpp\n");
            rc = Mat4x4InvCpp(m_inv, m, epsilon, &is_singular);
        }
        else
        {
            printf("\nCalculating inverse matrix - Mat4x4Inv_\n");
            rc = Mat4x4Inv_(m_inv, m, epsilon, &is_singular);
        }

        if (!rc)
        {
            if (is_singular)
                printf("Matrix 'm' is singular\n");
            else
                printf("Error occurred during calculation of matrix↵
                inverse\n");
        }
        else
        {
            Mat4x4Printf(m_inv, "\nInverse matrix\n");
            Mat4x4Mul(m_ver, m_inv, m);
            Mat4x4Printf(m_ver, "\nInverse matrix verification\n");
        }
    }
}

```

```

void Avx64CalcMat4x4Inv(void)
{
    __declspec(align(32)) Mat4x4 m;

    printf("Results for Avx64CalcMat4x4Inv\n");

    Mat4x4SetRow(m, 0, 2, 7, 3, 4);
    Mat4x4SetRow(m, 1, 5, 9, 6, 4.75);
    Mat4x4SetRow(m, 2, 6.5, 3, 4, 10);
    Mat4x4SetRow(m, 3, 7, 5.25, 8.125, 6);
    Avx64Mat4x4Inv(m, "\nTest Matrix #1\n");

    Mat4x4SetRow(m, 0, 0.5, 12, 17.25, 4);
    Mat4x4SetRow(m, 1, 5, 2, 6.75, 8);
    Mat4x4SetRow(m, 2, 13.125, 1, 3, 9.75);
    Mat4x4SetRow(m, 3, 16, 1.625, 7, 0.25);
    Avx64Mat4x4Inv(m, "\nTest Matrix #2\n");

    Mat4x4SetRow(m, 0, 2, 0, 0, 1);
    Mat4x4SetRow(m, 1, 0, 4, 5, 0);
    Mat4x4SetRow(m, 2, 0, 0, 0, 7);
    Mat4x4SetRow(m, 3, 0, 0, 0, 6);
    Avx64Mat4x4Inv(m, "\nTest Matrix #3\n");
}

int _tmain(int argc, _TCHAR* argv[])
{
#ifdef _DEBUG
    Avx64CalcMat4x4InvTest();
#endif
    Avx64CalcMat4x4Inv();
    Avx64CalcMat4x4InvTimed();
    return 0;
}

```

Listing 20-13. Avx64CalcMat4x4Inv.asm

```

include <MacrosX86-64.inc>

ConstVals segment readonly align(32) 'const'
VpermpsTranspose    dword 0,4,1,5,2,6,3,7
VpermsTrace        dword 0,2,5,7,0,0,0,0

Mat4x4I             real4 1.0, 0.0, 0.0, 0.0
                   real4 0.0, 1.0, 0.0, 0.0
                   real4 0.0, 0.0, 1.0, 0.0
                   real4 0.0, 0.0, 0.0, 1.0

```

```

r4_SignBitMask   dword 80000000h,80000000h,80000000h,80000000h
r4_AbsMask       dword 7fffffffh,7fffffffh,7fffffffh,7fffffffh

r4_1p0           real4 1.0
r4_N1p0          real4 -1.0
r4_N0p5          real4 -0.5
r4_N0p3333      real4 -0.3333333333
r4_N0p25        real4 -0.25
ConstVals ends
                .code

; _Mat4x4TraceYmm macro
;
; Description:  The following macro generates code that calculates the
;              trace of a 4x4 SPFP matrix in registers ymm1:ymm0.

_Mat4x4TraceYmm macro
    vblendps ymm0,ymm0,ymm1,84h                ;copy diagonals to ymm0
    vmovdqa ymm2,ymmword ptr [VpermsTrace]
    vpermps ymm1,ymm2,ymm0                    ;ymm1[127:0] = diagonals
    vhaddps ymm0,ymm1,ymm1
    vhaddps ymm0,ymm0,ymm0                    ;ymm0[31:0] = trace
    endm

; Mat4x4Mul
;
; Description:  The following function computes the product of two
;              4x4 matrices.
;
; Input:       ymm1:ymm0   m1
;              ymm3:ymm2   m2
;
; Output:      ymm1:ymm0   m1 * m2
;
; Notes:       In comments below, m2T denotes the transpose of matrix m2.

Mat4x4Mul proc private

; Calculate transpose of m2
    vmovdqa ymm6,ymmword ptr [VpermsTranspose] ;ymm6 = vperms indices
    vunpcklps ymm4,ymm2,ymm3
    vunpckhps ymm5,ymm2,ymm3                ;ymm5:ymm4 = partial transpose
    vpermps ymm2,ymm6,ymm4
    vpermps ymm3,ymm6,ymm5                ;ymm3:ymm2 = m2T

```

```

; Copy rows of m2T to ymm*[255:128] and ymm*[127:0]
    vperm2f128 ymm4,ymm2,ymm2,00000000b    ;ymm4 = m2T.row0
    vperm2f128 ymm5,ymm2,ymm2,00010001b    ;ymm5 = m2T.row1
    vperm2f128 ymm6,ymm3,ymm3,00000000b    ;ymm6 = m2T.row2
    vperm2f128 ymm7,ymm3,ymm3,00010001b    ;ymm7 = m2T.row3

; Perform mat4x4 multiplication, rows 0 and 1
; Note that all unused vdpps destination register elements are set to zero
; ymm8[31:0]      = dp(m1.row0, m2T.row0)
; ymm8[159:128]  = dp(m1.row1, m2T.row0)
; ymm9[63:32]    = dp(m1.row0, m2T.row1)
; ymm9[191:160] = dp(m1.row1, m2T.row1)
; ymm10[95:64]   = dp(m1.row0, m2T.row2)
; ymm10[223:192] = dp(m1.row1, m2T.row2)
; ymm11[127:96]  = dp(m1.row0, m2T.row3)
; ymm11[255:224] = dp(m1.row1, m2T.row3)
    vdpps ymm8,ymm0,ymm4,11110001b
    vdpps ymm9,ymm0,ymm5,11110010b
    vdpps ymm10,ymm0,ymm6,11110100b
    vdpps ymm11,ymm0,ymm7,11111000b
    vorps ymm8,ymm8,ymm9
    vorps ymm10,ymm10,ymm11
    vorps ymm0,ymm8,ymm10                ;ymm0 = rows 0 and 1

; Perform mat4x4 multiplication, rows 2 and 3
; ymm8[31:0]      = dp(m1.row2, m2T.row0)
; ymm8[159:128]  = dp(m1.row3, m2T.row0)
; ymm9[63:32]    = dp(m1.row2, m2T.row1)
; ymm9[191:160] = dp(m1.row3, m2T.row1)
; ymm10[95:64]   = dp(m1.row2, m2T.row2)
; ymm10[223:192] = dp(m1.row3, m2T.row2)
; ymm11[127:96]  = dp(m1.row2, m2T.row3)
; ymm11[255:224] = dp(m1.row3, m2T.row3)
    vdpps ymm8,ymm1,ymm4,11110001b
    vdpps ymm9,ymm1,ymm5,11110010b
    vdpps ymm10,ymm1,ymm6,11110100b
    vdpps ymm11,ymm1,ymm7,11111000b
    vorps ymm8,ymm8,ymm9
    vorps ymm10,ymm10,ymm11
    vorps ymm1,ymm8,ymm10                ;ymm1 = rows 2 and 3
    ret
Mat4x4Mul endp

; extern "C" bool Mat4x4Inv_(Mat4x4 m_inv, Mat4x4 m, float epsilon, bool*
is_singular);
;

```

```

; Description: The following function computes the inverse of a 4x4
;              matrix.
;
; Requires:    x86-64, AVX2
;
; Notes:      In the comments below, m2 = m * m, m3 = m * m * m, etc.

; Offsets of temporary values on the stack
OffsetM2Lo equ 0           ;m2 rows 0 and 1
OffsetM2Hi equ 32          ;m2 rows 2 and 3
OffsetM3Lo equ 64          ;m3 rows 0 and 1
OffsetM3Hi equ 96          ;m3 rows 2 and 3

Mat4x4Inv_ proc frame
    _CreateFrame Minv_,16,160
    _SaveXmmRegs xmm6,xmm7,xmm8,xmm9,xmm10,xmm11,xmm12,xmm13,xmm14,xmm15
    _EndProlog

; Perform required initializations and validations
    test rcx,01fh
    jnz Error                ;jump if m_inv is misaligned
    test rdx,01fh
    jnz Error                ;jump if m is misaligned
    vmovaps ymm14,[rdx]
    vmovaps ymm15,[rdx+32]   ;ymm15:ymm14 = m
    vmovss real4 ptr [rbp],xmm2 ;save epsilon for later use

; Allocate 128 bytes of 32-byte aligned stack space for temp matrices
    and rsp,0ffffffe0h      ;align rsp to 32-byte boundary
    sub rsp,128             ;alloc space for temp matrices

; Compute m2
    vmovaps ymm0,ymm14
    vmovaps ymm1,ymm15      ;ymm1:ymm0 = m
    vmovaps ymm2,ymm14
    vmovaps ymm3,ymm15      ;ymm3:ymm2 = m
    call Mat4x4Mul          ;ymm1:ymm0 = m2
    vmovaps [rsp+OffsetM2Lo],ymm0
    vmovaps [rsp+OffsetM2Hi],ymm1 ;save m2

; Compute m3
    vmovaps ymm2,ymm14
    vmovaps ymm3,ymm15      ;ymm3:ymm2 = m
    call Mat4x4Mul          ;ymm1:ymm0 = m3
    vmovaps [rsp+OffsetM3Lo],ymm0
    vmovaps [rsp+OffsetM3Hi],ymm1 ;save m3
    vmovaps ymm12,ymm0
    vmovaps ymm13,ymm1      ;ymm13:ymm12 = m3

```

```

; Compute m4
    vmovaps ymm2,ymm14
    vmovaps ymm3,ymm15                ;ymm3:ymm2 = m
    call Mat4x4Mul                    ;ymm1:ymm0 = m4

; Compute and save matrix trace values
    _Mat4x4TraceYmm
    vmovss xmm10,xmm0,xmm0           ;xmm10 = t4

    vmovaps ymm0,ymm12
    vmovaps ymm1,ymm13
    _Mat4x4TraceYmm
    vmovss xmm9,xmm0,xmm0           ;xmm9 = t3

    vmovaps ymm0,[rsp+OffsetM2Lo]
    vmovaps ymm1,[rsp+OffsetM2Hi]
    _Mat4x4TraceYmm
    vmovss xmm8,xmm0,xmm0           ;xmm8 = t2

    vmovaps ymm0,ymm14
    vmovaps ymm1,ymm15
    _Mat4x4TraceYmm
    vmovss xmm7,xmm0,xmm0           ;xmm7 = t1

; Calculate the required coefficients
; c1 = -t1;
; c2 = -1.0f / 2.0f * (c1 * t1 + t2);
; c3 = -1.0f / 3.0f * (c2 * t1 + c1 * t2 + t3);
; c4 = -1.0f / 4.0f * (c3 * t1 + c2 * t2 + c1 * t3 + t4);
;
; Registers used: t1-t4 = xmm7-xmm10, c1-c4 = xmm12-xmm15
    vxorps xmm12,xmm7,real4 ptr [r4_SignBitMask] ;xmm12 = c1

    vmulss xmm13,xmm12,xmm7          ;c1 * t1
    vaddss xmm13,xmm13,xmm8          ;c1 * t1 + t2
    vmulss xmm13,xmm13,[r4_Nop5]    ;xmm13 = c2

    vmulss xmm14,xmm13,xmm7          ;c2 * t1
    vmulss xmm0,xmm12,xmm8          ;c1 * t2
    vaddss xmm14,xmm14,xmm0          ;c2 * t1 + c1 * t2
    vaddss xmm14,xmm14,xmm9          ;c2 * t1 + c1 * t2 + t3
    vmulss xmm14,xmm14,[r4_Nop3333] ;xmm14 = c3

    vmulss xmm15,xmm14,xmm7          ;c3 * t1
    vmulss xmm0,xmm13,xmm8          ;c2 * t2
    vmulss xmm1,xmm12,xmm9          ;c1 * t3
    vaddss xmm2,xmm0,xmm1           ;c2 * t2 + c1 * t3

```

```

    vaddss xmm15,xmm15,xmm2           ;c3 * t1 + c2 * t2 + c1 * t3
    vaddss xmm15,xmm15,xmm10        ;c3 * t1 + c2 * t2 + c1 * t3 + t4
    vmulss xmm15,xmm15,[r4_N0p25]   ;xmm15 = c4

; Make sure matrix is not singular
    vandps xmm1,xmm15,[r4_AbsMask]  ;compute fabs(c4)
    vcomiss xmm1,real4 ptr [rbp]    ;compare against epsilon
    setp al                          ;set al = if unordered
    setb ah                          ;set ah = if fabs(c4) < epsilon
    or al,ah                        ;al = is_singular
    mov [r9],al                    ;save is_singular state
    jnz Error                       ;jump if singular

; Calculate m_inv = -1.0 / c4 * (m3 + c1 * m2 + c2 * m1 + c3 * I)
    vmovaps ymm0,[rsp+OffsetM3Lo]
    vmovaps ymm1,[rsp+OffsetM3Hi]   ;ymm1:ymm0 = m3

    vbroadcastss ymm12,xmm12
    vmulps ymm2,ymm12,[rsp+OffsetM2Lo]
    vmulps ymm3,ymm12,[rsp+OffsetM2HI] ;ymm3:ymm2 = c1 * m2

    vbroadcastss ymm13,xmm13
    vmulps ymm4,ymm13,[rdx]
    vmulps ymm5,ymm13,[rdx+32]     ;ymm5:ymm4 = c2 * m

    vbroadcastss ymm14,xmm14
    vmulps ymm6,ymm14,[Mat4x4I]
    vmulps ymm7,ymm14,[Mat4x4I+32] ;ymm7:ymm6 = c3 * I

    vaddps ymm0,ymm0,ymm2
    vaddps ymm1,ymm1,ymm3           ;ymm1:ymm0 = m3 + c1*m2
    vaddps ymm8,ymm4,ymm6
    vaddps ymm9,ymm5,ymm7           ;ymm9:ymm8 = c2*m + c3*I
    vaddps ymm0,ymm0,ymm8
    vaddps ymm1,ymm1,ymm9           ;ymm1:ymm0 = matrix sum

    vmovss xmm2,[r4_N1p0]
    vdivss xmm2,xmm2,xmm15          ;xmm2 = -1.0 / c4
    vbroadcastss ymm2,xmm2
    vmulps ymm0,ymm0,ymm2
    vmulps ymm1,ymm1,ymm2          ;ymm1:ymm0 = m_inv

    vmovaps [rcx],ymm0
    vmovaps [rcx+32],ymm1          ;save m_inv
    mov eax,1                      ;set success return code

```



```

Done:   vzeroupper
        _RestoreXmmRegs xmm6,xmm7,xmm8,xmm9,xmm10,xmm11,xmm12,xmm13,
xmm14,xmm15
        _DeleteFrame
        ret

Error:  xor eax,eax
        jmp Done
Mat4x4Inv_ endp

; The following functions are for software test & debug.
Mat4x4Trace_ proc
        _Mat4x4TraceYmm
        ret
Mat4x4Trace_ endp
Mat4x4Mul_ proc
        call Mat4x4Mul
        ret
Mat4x4Mul_ endp
        end

```

The multiplicative inverse of a matrix is defined as follows. Let **A** and **X** represent $n \times n$ matrices. Matrix **X** is an inverse of **A** if $\mathbf{AX} = \mathbf{XA} = \mathbf{I}$ is true, where **I** denotes an $n \times n$ identity matrix. Figure 20-4 shows an example of an inverse matrix. It should be noted that inverses do not exist for all $n \times n$ matrices. A matrix that does not have an inverse is called a singular matrix.

$$\mathbf{A} = \begin{bmatrix} 6 & 2 & 2 \\ 2 & -2 & 2 \\ 0 & 4 & 2 \end{bmatrix} \quad \mathbf{X} = \begin{bmatrix} 0.1875 & -0.0625 & -0.125 \\ 0.0625 & -0.1875 & 0.125 \\ -0.125 & 0.375 & 0.25 \end{bmatrix} \quad \mathbf{AX} = \mathbf{XA} = \mathbf{I} = \begin{bmatrix} 1 & 0 & 0 \\ 0 & 1 & 0 \\ 0 & 0 & 1 \end{bmatrix}$$

Figure 20-4. Matrix **A** and its multiplicative inverse, Matrix **X**

The inverse of a matrix can be calculated using a variety of mathematical techniques. The sample program `Avx64CalcMat4x4Inv` uses a computational method based on the Cayley-Hamilton theorem, which employs common matrix operations that are easy to carry out using SIMD arithmetic. Figure 20-5 defines the equations necessary to calculate the inverse of a 4×4 matrix. Note that the *trace* of a matrix is simply the sum of its diagonal elements.

$$\mathbf{A}^1 = \mathbf{A}, \mathbf{A}^2 = \mathbf{AA}, \mathbf{A}^3 = \mathbf{AAA}, \mathbf{A}^4 = \mathbf{AAAA}$$

$$t_n = \text{trace}(\mathbf{A}^n) \qquad \text{trace}(\mathbf{A}) = \sum_{i=0}^{n-1} a_{ii}$$

$$c_1 = -t_1$$

$$c_2 = -\frac{1}{2}(c_1 t_1 + t_2)$$

$$c_3 = -\frac{1}{3}(c_2 t_1 + c_1 t_2 + t_3)$$

$$c_4 = -\frac{1}{4}(c_3 t_1 + c_2 t_2 + c_1 t_3 + t_4)$$

$$\mathbf{A}^{-1} = -\frac{1}{c_4}(\mathbf{A}^3 + c_1 \mathbf{A}^2 + c_2 \mathbf{A} + c_3 \mathbf{I})$$

Figure 20-5. Calculation of a 4×4 matrix inverse

Listing 20-12 shows the C++ code for sample program `Avx64CalcMat4x4Inv`. Toward the top of this listing is a function named `Mat4x4InvCp`, which calculates the inverse of a 4×4 single-precision floating-point matrix using the equations presented in Figure 20-5. Following validation of the `Mat4x4` arguments `m` and `m_inv` for proper alignment, the function `Mat4x4InvCp` calculates the values `t1-t4` using the helper functions `Mat4x4Mul` and `Max4x4Trace` (the source code for these helper functions is not shown but included as part of the downloadable software package). Values `c1-c4` are calculated next using simple scalar floating-point arithmetic. If the value of `c4` is zero, the matrix `m` is singular and the function `Mat4x4InvCp` terminates. Otherwise, the final inverse matrix is calculated and saved to `m_inv`.

The assembly language file `Avx64CalcMat4x4Inv.asm` (Listing 20-13) defines a macro named `_Mat4x4TraceYmm`, which computes the trace of a 4×4 matrix of single-precision floating-point values. This macro requires its source 4×4 matrix to be loaded in registers `YMM0` (rows 0 and 1) and `YMM1` (rows 2 and 3). The macro uses the `vblendps`, `vpermps`, and `vhaddps` instructions to calculate the trace value, as illustrated in Figure 20-6.

$$\mathbf{M} = \begin{bmatrix} 7 & 2 & 19 & 3 \\ 8 & 6 & 5 & 10 \\ 22 & 3 & 1 & 12 \\ 13 & 25 & 9 & 4 \end{bmatrix}$$

ymm0[127:0] = row0, ymm0[255:128] = row1

10.0	5.0	6.0	8.0	3.0	19.0	2.0	7.0	ymm0
------	-----	-----	-----	-----	------	-----	-----	------

ymm1[127:0] = row2, ymm1[255:128] = row3

4.0	9.0	25.0	13.0	12.0	1.0	3.0	22.0	ymm1
-----	-----	------	------	------	-----	-----	------	------

vblendps ymm0, ymm0, ymm1, 84h

4.0	5.0	6.0	8.0	3.0	1.0	2.0	7.0	ymm0
-----	-----	-----	-----	-----	-----	-----	-----	------

vmovdqqa ymm2, ymmword ptr [VpermsTrace]

0	0	0	0	7	5	2	0	ymm2
---	---	---	---	---	---	---	---	------

vpermpps ymm1, ymm2, ymm0

#	#	#	#	4.0	6.0	1.0	7.0	ymm1
---	---	---	---	-----	-----	-----	-----	------

vhaddps ymm0, ymm1, ymm1

#	#	#	#	#	#	10	8	ymm0
---	---	---	---	---	---	----	---	------

vhaddps ymm0, ymm0, ymm0

#	#	#	#	#	#	#	18.0	ymm0
---	---	---	---	---	---	---	------	------

= Don't Care

Figure 20-6. Calculation of a matrix trace value

Following definition of the macro `_Max4x4TraceYmm` is a private function named `Mat4x4Mul`. This function computes the product of two 4x4 single-precision floating-point matrices. The technique employed here is similar to the method used in Chapter 10. First, the transpose of matrix `m2` is calculated using the `vunpcklps`, `vunpckhps`, and `vpermps` instructions, as shown in Figure 20-7. Each row of the transposed matrix is then copied to the lower and upper 128 bits of a YMM register using the `vperm2f128` (Permute Floating-Point Values) instruction. The duplication of each matrix row reduces the number of dot product calculations that must be performed from 16 to 8. The final matrix product is calculated using a series of `vdpps` and `vorps` instructions. Note that the unused elements of each `vdpps` YMM destination operand are set to 0.0, which facilitates use of the `vorps` instruction to calculate the final values.

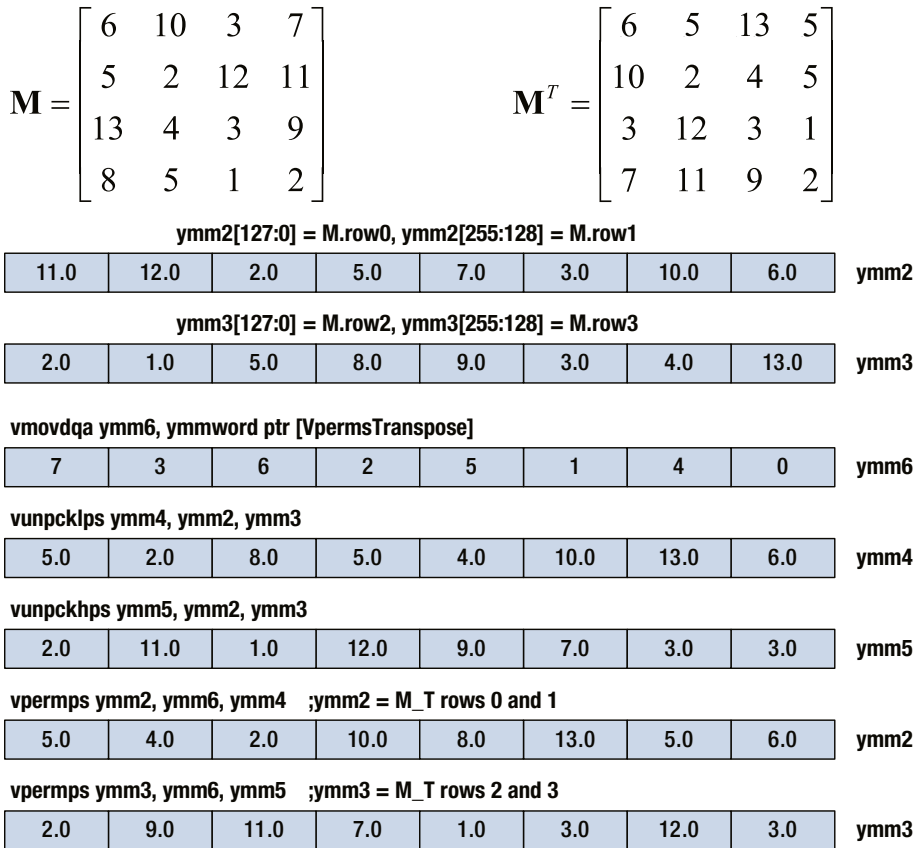

Figure 20-7. Calculation of a matrix transpose

The `Max4x4Inv_` function computes its inverse using the same logic as its C++ counterpart. First, the trace values `t1-t4` are calculated using the function `Mat4x4Mul` and macro `_Mat4x4TraceYmm`. The coefficients `c1-c4` are calculated next using x86-AVX scalar floating-point arithmetic. The coefficient `c4` is then tested to ensure that the source matrix is not singular. Finally, the required matrix inverse is computed. Note that all of the arithmetic necessary to calculate the inverse matrix is carried out using straightforward packed multiplication (`vmulps`) and addition (`vaddps`). Output 20-6 shows the results for sample program `Avx64Mat4x4Inv`. Table 20-3 also contains some timing measurements.

Output 20-6. Sample Program Avx64CalcMat4x4Inv

Results for Avx64CalcMat4x4Inv

Test Matrix #1

2.000000	7.000000	3.000000	4.000000
5.000000	9.000000	6.000000	4.750000
6.500000	3.000000	4.000000	10.000000
7.000000	5.250000	8.125000	6.000000

Calculating inverse matrix - Mat4x4InvCpp

Inverse matrix

-0.943926	0.916570	0.197547	-0.425579
-0.056882	0.251148	0.003028	-0.165952
0.545399	-0.647656	-0.213597	0.505123
0.412456	-0.412053	0.056125	0.124363

Inverse matrix verification

1.000000	-0.000000	0.000000	-0.000000
0.000000	1.000000	0.000000	0.000000
-0.000000	0.000000	1.000000	0.000000
0.000000	0.000000	0.000000	1.000000

Calculating inverse matrix - Mat4x4Inv_

Inverse matrix

-0.943926	0.916570	0.197547	-0.425579
-0.056882	0.251148	0.003028	-0.165952
0.545399	-0.647656	-0.213597	0.505123
0.412456	-0.412053	0.056125	0.124363

Inverse matrix verification

1.000000	-0.000000	0.000000	-0.000000
0.000000	1.000000	0.000000	0.000000
-0.000000	0.000000	1.000000	0.000000
0.000000	0.000000	0.000000	1.000000

Test Matrix #2

0.500000	12.000000	17.250000	4.000000
5.000000	2.000000	6.750000	8.000000
13.125000	1.000000	3.000000	9.750000
16.000000	1.625000	7.000000	0.250000

Calculating inverse matrix - Mat4x4InvCpp

Inverse matrix

0.001652	-0.069024	0.054959	0.038935
0.135369	-0.359846	0.242038	-0.090325
-0.035010	0.239298	-0.183964	0.077221
-0.005335	0.056194	0.060361	-0.066908

Inverse matrix verification

1.000001	0.000000	0.000000	0.000000
-0.000000	1.000000	-0.000000	-0.000000
0.000000	0.000000	1.000001	0.000000
0.000000	0.000000	0.000000	1.000001

Calculating inverse matrix - Mat4x4Inv_

Inverse matrix

0.001652	-0.069024	0.054959	0.038935
0.135369	-0.359846	0.242038	-0.090325
-0.035010	0.239298	-0.183964	0.077221
-0.005335	0.056194	0.060361	-0.066908

Inverse matrix verification

1.000001	0.000000	0.000000	0.000000
-0.000000	1.000000	-0.000000	-0.000000
0.000000	0.000000	1.000001	0.000000
0.000000	0.000000	0.000000	1.000001

Test Matrix #3

2.000000	0.000000	0.000000	1.000000
0.000000	4.000000	5.000000	0.000000
0.000000	0.000000	0.000000	7.000000
0.000000	0.000000	0.000000	6.000000

Calculating inverse matrix - Mat4x4InvCpp

Matrix 'm' is singular

Calculating inverse matrix - Mat4x4Inv_

Matrix 'm' is singular

Benchmark times saved to file __Avx64CalcMat4x4InvTimed.csv

Table 20-3. Mean Execution Times (in Microseconds) for Matrix Inverse Functions in Sample Program *Avx64CalcMat4x4Inv* (10,000 Matrix Inverse Operations)

CPU	C++	x86-AVX-64
Intel Core i7-4770	980	420
Intel Core i7-4600U	1194	491

Miscellaneous Instructions

The last sample program in this chapter, which is named `Avx64MiscInstructions`, demonstrates how to exercise select gather and half-precision floating-point instructions in a 64-bit assembly language function. Listings 20-14 and 20-15 show the C++ and assembly language source code for sample program `Avx64MiscInstructions`.

Listing 20-14. `Avx64MiscInstructions.cpp`

```
#include "stdafx.h"
#include "MiscDefs.h"
#define _USE_MATH_DEFINES
#include <math.h>

extern "C" void Avx64GatherFloatIndx32_(float g[8], const float* x, Int32_
indices[8]);
extern "C" void Avx64GatherFloatIndx64_(float g[4], const float* x, Int64_
indices[4]);
extern "C" void Avx64FloatToHp_(UInt16 x_hp[8], float x1[8]);
extern "C" void Avx64HpToFloat_(float x[8], UInt16 x_hp[8]);

void Avx64GatherFloat(void)
{
    const int n = 20;
    float x1[n];

    printf("Results for Avx64GatherFloat()\n");
    printf("\nSource array\n");

    for (int i = 0; i < n; i++)
    {
        x1[i] = i * 100.0f;
        printf("x1[%02d]: %.1f\n", i, x1[i]);
    }
    printf("\n");

    float g1_32[8], g1_64[4];
    Int32 g1_indices32[8] = {2, 3, 7, 1, 1, 12, 4, 17};
    Int64 g1_indices64[4] = {5, 0, 19, 13};
```

```

    Avx64GatherFloatIndx32_(g1_32, x1, g1_indices32);
    for (int i = 0; i < 8; i++)
        printf("g1_32[%02d] = %.1f (gathered from x[%02d])\n", i, g1_32[i],
g1_indices32[i]);

    printf("\n");

    Avx64GatherFloatIndx64_(g1_64, x1, g1_indices64);
    for (int i = 0; i < 4; i++)
        printf("g1_64[%02d] = %.1f (gathered from x[%02lld])\n", i,
g1_64[i], g1_indices64[i]);
}

void Avx64HalfPrecision(void)
{
    float x1[8], x2[8];
    Uint16 x_hp[8];

    x1[0] = 0.5f;           x1[1] = 1.0f / 512.0f;
    x1[2] = 1004.0625f;    x1[3] = 5003.125f;
    x1[4] = 42000.5f;      x1[5] = 75600.875f;
    x1[6] = -6002.125f;    x1[7] = (float)M_PI;

    Avx64FloatToHp_(x_hp, x1);
    Avx64HpToFloat_(x2, x_hp);

    printf("\nResults for Avx64HalfPrecision()\n");

    for (int i = 0; i < 8; i++)
        printf("%d %16.6f %16.6f\n", i, x1[i], x2[i]);
}

int _tmain(int argc, _TCHAR* argv[])
{
    Avx64GatherFloat();
    Avx64HalfPrecision();
    return 0;
}

```

Listing 20-15. Avx64MiscInstructions_.asm

```

    include <Macrosx86-64.inc>

    .const
MaskVgatherdps    dword 80000000h,80000000h,80000000h,80000000h
                  dword 80000000h,80000000h,80000000h,80000000h
MaskVgatherqps    dword 80000000h,80000000h,80000000h,80000000h
    .code

```



```

; extern "C" void Avx64GatherFloatIndx32_(float g[8], const float* x, Int32
indices[8]);
;
; Description: The following function demonstrates use of the
;             vgatherdps instruction.
;
; Requires    X86-64, AVX2

```

```

Avx64GatherFloatIndx32_ proc
    vmovdqu ymm0,ymmword ptr [r8]
    vmovdqu ymm1,ymmword ptr [MaskVgatherdps]

    vgatherdps ymm2,[rdx+ymm0*4],ymm1    ;ymm2 = gathered SPFP values

    vmovups ymmword ptr [rcx],ymm2      ;save result
    vzeroupper
    ret
Avx64GatherFloatIndx32_ endp

```

```

; extern "C" void Avx64GatherFloatIndx64_(float g[4], const float* x, Int64
indices[4]);
;
; Description: The following function demonstrates use of the
;             vgatherqps instruction.
;
; Requires    X86-64, AVX2

```

```

Avx64GatherFloatIndx64_ proc
    vmovdqu ymm0,ymmword ptr [r8]
    vmovdqu xmm1,xmmword ptr [MaskVgatherqps]

    vgatherqps xmm2,[rdx+ymm0*4],xmm1    ;xmm2 = gathered SPFP values

    vmovups xmmword ptr [rcx],xmm2      ;save result
    vzeroupper
    ret
Avx64GatherFloatIndx64_ endp

```

```

; extern "C" void Avx64FloatToHp_(Uint16 x_hp[8], float x1[8]);
;
; Description: The following function converts an array of eight
;             SPFP values to HPFP.
;
; Requires    X86-64, AVX, F16C

```

```

Avx64FloatToHp_ proc
    vmovups ymm0,ymmword ptr [rdx]
    vcvtps2ph xmmword ptr [rcx],ymm0,00000100b ;use round to nearest
    ret
Avx64FloatToHp_ endp

; extern "C" void Avx64HpToFloat_(float x[8], Uint16 x_hp[8]);
;
; Description:   The following function converts an array of eight
;               HPFP values to SPFP.
;
; Requires      X86-64, AVX, F16C

Avx64HpToFloat_ proc
    vcvtp2ps ymm0,xmmword ptr [rdx]
    vmovups ymmword ptr [rcx],ymm0
    ret
Avx64HpToFloat_ endp
end

```

The C++ file `Avx64MiscInstructions.cpp` (Listing 20-14) includes a function named `Avx64GatherFloat`. This function initializes the data and index arrays that are used by the assembly language functions `Avx64GatherFloatIndx32_` and `Avx64GatherFloatIndx64_`. The file `Avx64MiscInstructions.cpp` also contains a function named `Avx64HalfPrecision`, which exercises the half-precision floating-point conversion functions `Avx64FloatToHp_` and `Avx64HpToFloat_`. Note that an array of type `Uint16` is used to temporarily store the half-precision floating-point values since C++ does not natively support a half-precision floating-point data type.

Listing 20-15 shows the assembly language functions for sample program `Avx64MiscInstructions`. The functions `Avx64GatherFloatIndx32_` and `Avx64GatherFloatIndx64_` demonstrate use of the `vgatherdps` and `vgatherqps` instructions, respectively. (Figure 12-4 illustrates execution of the `vgatherdps` instruction.) Note that the former instruction uses doubleword indices while the latter uses quadwords. The use of quadword indices by `vgatherqps` means that it can gather only four single-precision floating-point values instead of eight.

The assembly language file `Avx64MiscInstructions.asm` also contains the half-precision conversion functions `Avx64FloatToHp_` and `Avx64HpToFloat_`. These functions use the conversion instructions `vcvtps2ph` (Convert Single-Precision FP Value to 16-bit FP Value) and `vcvtp2ps` (Convert 16-bit FP Values to Single-Precision FP Values) to perform single-precision to half-precision floating-point conversions and vice versa. Note that the `vcvtps2ph` instruction includes an immediate operand that specifies the rounding method to use during the conversion. Table 20-4 shows the rounding options for the `vcvtps2ph` instruction.

Table 20-4. Rounding Options for `vcvtps2ph` Instruction

Operand Bits	Value	Description
1:0	00	Round to nearest
	01	Round down
	10	Round up
	11	Truncate
2	0	Use bits 1:0 for rounding
	1	Use bits MXCSR.RC for rounding
7:3		Not used

Output 20-7 shows the results for sample program `Avx64MiscInstructions`. Note the magnitude of rounding that occurs when a single-precision floating-point value is converted to half-precision floating-point. Also note that the value 75600.875 was converted to infinity since it's greater than the largest possible half-precision floating-point value (the `printf` function displays the text `1.#INF00` for infinity). The half-precision floating-point conversion instructions are primarily intended to reduce storage requirements, as discussed in Chapter 12.

Output 20-7. Sample Program `Avx64MiscInstructions`

Results for `Avx64GatherFloat()`

```
Source array
x1[00]: 0.0
x1[01]: 100.0
x1[02]: 200.0
x1[03]: 300.0
x1[04]: 400.0
x1[05]: 500.0
x1[06]: 600.0
x1[07]: 700.0
x1[08]: 800.0
x1[09]: 900.0
x1[10]: 1000.0
x1[11]: 1100.0
x1[12]: 1200.0
x1[13]: 1300.0
x1[14]: 1400.0
x1[15]: 1500.0
x1[16]: 1600.0
```

```
x1[17]: 1700.0
x1[18]: 1800.0
x1[19]: 1900.0
```

```
g1_32[00] = 200.0 (gathered from x[02])
g1_32[01] = 300.0 (gathered from x[03])
g1_32[02] = 700.0 (gathered from x[07])
g1_32[03] = 100.0 (gathered from x[01])
g1_32[04] = 100.0 (gathered from x[01])
g1_32[05] = 1200.0 (gathered from x[12])
g1_32[06] = 400.0 (gathered from x[04])
g1_32[07] = 1700.0 (gathered from x[17])
```

```
g1_64[00] = 500.0 (gathered from x[05])
g1_64[01] = 0.0 (gathered from x[00])
g1_64[02] = 1900.0 (gathered from x[19])
g1_64[03] = 1300.0 (gathered from x[13])
```

```
Results for Avx64HalfPrecision()
```

0	0.500000	0.500000
1	0.001953	0.001953
2	1004.062500	1004.000000
3	5003.125000	5004.000000
4	42000.500000	42016.000000
5	75600.875000	1.#INF00
6	-6002.125000	-6004.000000
7	3.141593	3.140625

Summary

In this chapter, you learned how to use the computational resources of x86-SSE and x86-AVX in an x86-64 execution environment. You also discovered that the performance of a SIMD algorithm can vary depending on the organization of its data structures. In the next two chapters, you learn about some additional programming strategies that can be employed to optimize the performance of x86 assembly language functions.



Advanced Topics and Optimization Techniques

In order to maximize the performance of your assembly language code, you need to understand a few pivotal details about the inner workings of an x86 processor. In this chapter, you'll study the internal architecture of a modern x86 multi-core processor and its underlying microarchitecture. Boosting assembly language software performance also requires appropriate use of certain x86 coding strategies and techniques, which are also examined in this chapter.

The content of this chapter should be regarded as an introductory tutorial to its topics. A comprehensive examination of x86 microarchitectures and assembly language optimization techniques would minimally require several lengthy chapters, or conceivably an entire book. The primary reference source for this chapter's material is the *Intel 64 and IA-32 Architectures Optimization Reference Manual*. You are encouraged to consult this important reference guide for additional information and insights regarding x86 microarchitectures and assembly language optimization techniques.

■ **Note** You can download the *Intel 64 and IA-32 Architectures Optimization Reference Manual* and other important x86 software developer manuals from the following Intel website: <http://www.intel.com/content/www/us/en/processors/architectures-software-developer-manuals.html>.

Processor Microarchitecture

The performance capabilities of an x86 processor are principally determined by its underlying microarchitecture. A processor's microarchitecture is characterized by the organization and operation of its internal hardware components, which include instruction pipelines, decoders, schedulers, execution units, data buses, and caches. Developers who understand the basics of a processor's microarchitecture can often glean constructive insights that enable them to develop more efficient code.

Companies such as AMD and Intel regularly market processors based on enhanced or new microarchitectures. In the discussions that follow, I describe the high-level organization of Intel's Haswell microarchitecture, which is used in fourth-generation Core i7, i5, and i3 series processors. The structural organization and operation of earlier Intel microarchitectures such as Nehalem, Sandy Bridge, and Ivy Bridge (or first, second, and third generation Core i7, i5, and i3 series processors) are similar to Haswell, although the latter includes significant enhancements in terms of performance and reduced power consumption.

Multi-Core Processor Overview

The architectural details of a processor based on Haswell or any other modern microarchitecture are best examined using the framework of a multi-core processor. Figure 21-1 shows a simplified block diagram of a typical Haswell-based quad-core processor. Note that each CPU core includes first-level (L1) instruction and data caches, which are labeled I-Cache and D-Cache. As implied by their names, these memory caches contain instructions and data that a CPU core can rapidly access. Each CPU core also includes a second-level (L2) unified cache, which holds both instructions and data. The L1 and L2 caches enable the CPU cores to carry out independent operations in parallel without having to access the higher-level L3 shared cache or main memory.

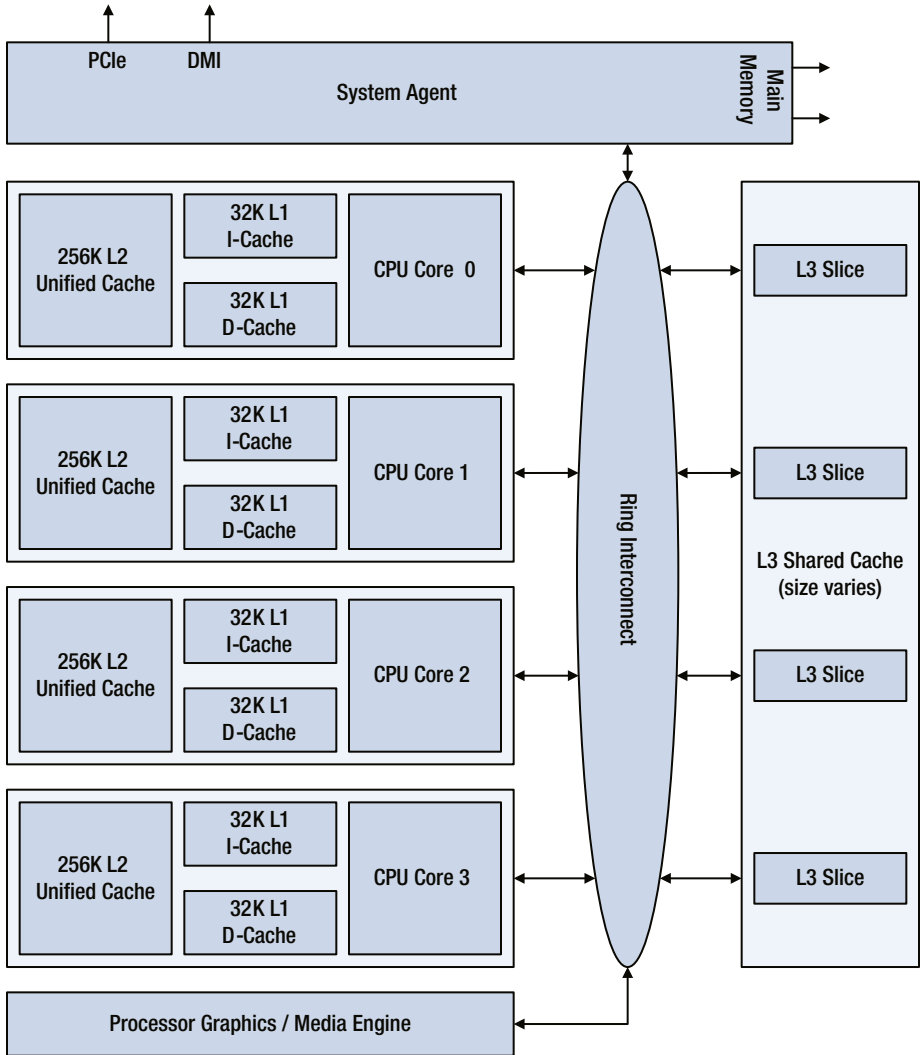

Figure 21-1. Simplified block diagram of a Haswell-based quad-core processor

If a CPU core requires an instruction or data item that is not present in its L1 or L2 cache, it must be loaded from the L3 cache or main memory. The L3 cache is partitioned into multiple “slices.” Each slice consists of a logic controller and data array. The logic controller manages access to its corresponding data array. It also handles cache misses and writes to main memory (a cache miss occurs when requested data is not found in the cache and must be loaded from main memory). The data array includes the actual cache data, which is organized into 64-byte wide packets called *cache lines*. The Ring

Interconnect is a high-speed internal bus that facilitates data transfers between the CPU cores, L3 cache, graphics unit, and System Agent. The System Agent handles data traffic among the processor, its external data buses, and main memory.

Microarchitecture Pipeline Functionality

During program execution, a CPU core performs five elementary instructional operations: fetch, decode, dispatch, execute, and retire. The particulars of these operations are determined by the functionality of the CPU’s microarchitecture pipeline. Figure 21-2 shows a streamlined block diagram of CPU pipeline functionality in a Haswell-based processor. In the paragraphs that follow, the operations performed by these pipeline units are examined in greater detail.

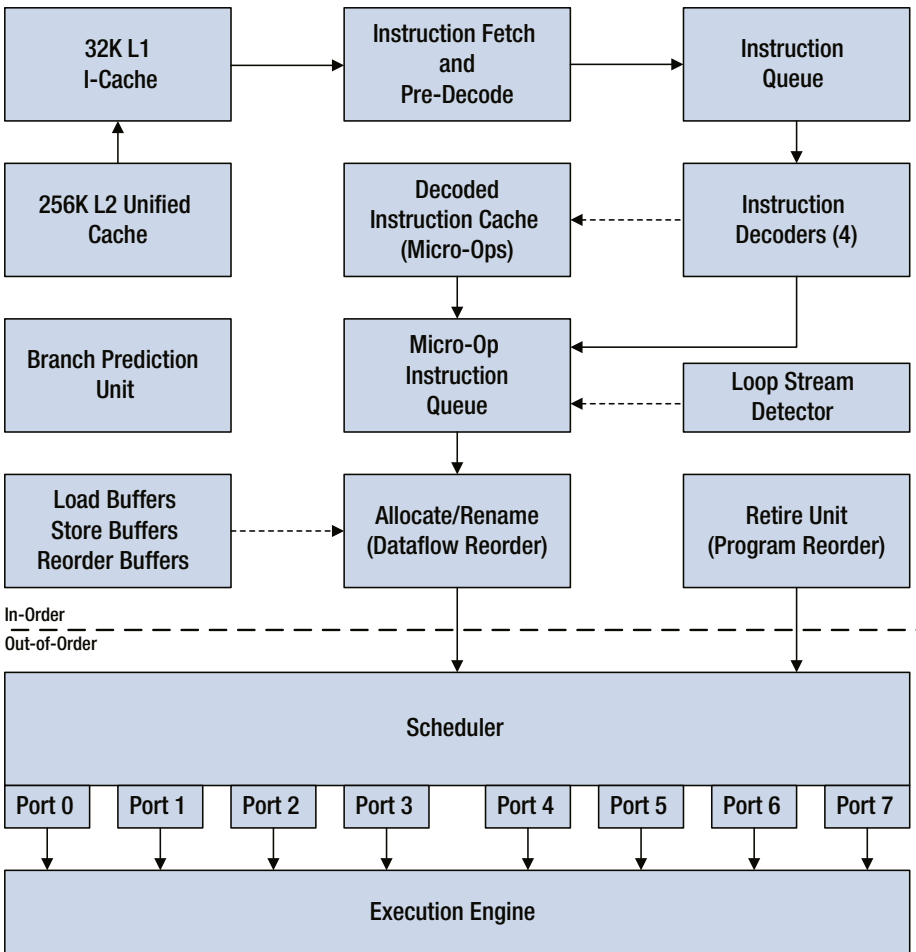

Figure 21-2. Haswell CPU core pipeline functionality

The Instruction Fetch and Pre-Decode Unit grabs instructions from the L1 I-Cache and begins the process of preparing them for execution. Steps performed by this stage include instruction length resolution, decoding of x86 instructional prefixes, and property marking to assist the downstream decoders. The Instruction Fetch and Pre-Decode Unit is also responsible for feeding a constant stream of instructions to the Instruction Queue, which queues up instructions for presentation to the Instruction Decoders.

The Instruction Decoders translate x86 instructions into *micro-ops*. A micro-op is a self-contained low-level instruction that is ultimately executed by one of the Execution Engine's Execution Units, which are discussed in the next section. The number of micro-ops generated by the decoders for an x86 instruction varies depending on its complexity. Simple register-register instructions such as `add eax,edx` and `pxor xmm0,xmm0` are decoded into a single micro-op. Instructions that perform more complex operations, such as `idiv rcx` and `vdivpd ymm0,ymm1,ymm2`, require multiple micro-ops. The translation of x86 instructions into micro-ops facilitates a number of architectural and performance benefits, including instruction-level parallelism and out-of-order executions.

The Instruction Decoders also perform two ancillary operations that improve utilization of available pipeline bandwidth. The first of these operations is called *micro-fusion*, which combines simple micro-ops from the same x86 instruction into a single complex micro-op. Examples of micro-fused instructions include memory stores (`mov [ebx+16],eax`) and calculating instructions that reference operands in memory (`sub r9,qword ptr [rbp+48]`). Fused complex micro-ops are dispatched by the Execution Engine multiple times (each dispatch executes a simple micro-op from the original instruction). The second ancillary operation carried out by the Instruction Decoders is called *macro-fusion*. Macro-fusion combines certain commonly-used x86 instruction pairs into a single micro-op. Examples of macro-fusible instruction pairs include many (but not all) conditional jump instructions that are preceded by an `add`, `and`, `cmp`, `dec`, `inc`, `sub`, or `test` instruction.

Micro-ops from the Instruction Decoders are transferred to the Micro-Op Instruction Queue for eventual dispatch by the Scheduler. They're also cached, when necessary, in the Decoded Instruction Cache. The Micro-Op Instruction Queue is also used by the Loop Stream Detector, which identifies and locks small program loops in the Micro-Op Instruction Queue. This improves performance since a small loop can repeatedly execute without requiring any additional instruction fetch, decode, and micro-op cache read operations.

The Allocate/Rename block serves as a bridge between the in-order front-end pipelines and the out-of-order Scheduler and Execution Engine. It allocates any needed internal buffers to the micro-ops. It also eliminates false dependencies between micro-ops, which facilitates out-of-order execution. (A false dependency occurs when two micro-ops need to simultaneously access distinct versions of the same hardware resource.) Micro-ops are then transferred to the Scheduler. This unit queues micro-ops until all of the necessary source operands are available. It then dispatches ready-to-execute micro-ops to the appropriate Execution Unit in the Execution Engine. The Retire Unit removes micro-ops that have completed their execution using the program's original instruction-ordering pattern. It also signals any processor exceptions that may have occurred during micro-op execution.

Finally, the Branch Prediction Unit helps select the next set of instructions to execute by predicting the branch targets that are most likely to execute based on recent code execution patterns. A branch target is simply the destination operand of a transfer control

instruction, such as `jcc`, `jmp`, `call`, or `ret`. The Branch Prediction Unit enables a CPU core to speculatively execute the micro-ops of an instruction before the outcome of a branch decision is known. When necessary, a CPU core searches (in order) the Decoded Instruction Cache, L1 I-Cache, L2 Unified Cache, L3 Cache, and main memory for instructions to execute.

Execution Engine

The Execution Engine executes micro-ops passed to it by the Scheduler. Figure 21-3 shows a high-level block diagram of a Haswell CPU Core Execution Engine. The rectangular blocks beneath each dispatch port denote micro-op Execution Units. Note that four of the Scheduler ports facilitate access to Execution Units that carry out calculating functions including integer, floating-point, and SIMD arithmetic. The remaining four ports support memory load and store operations.

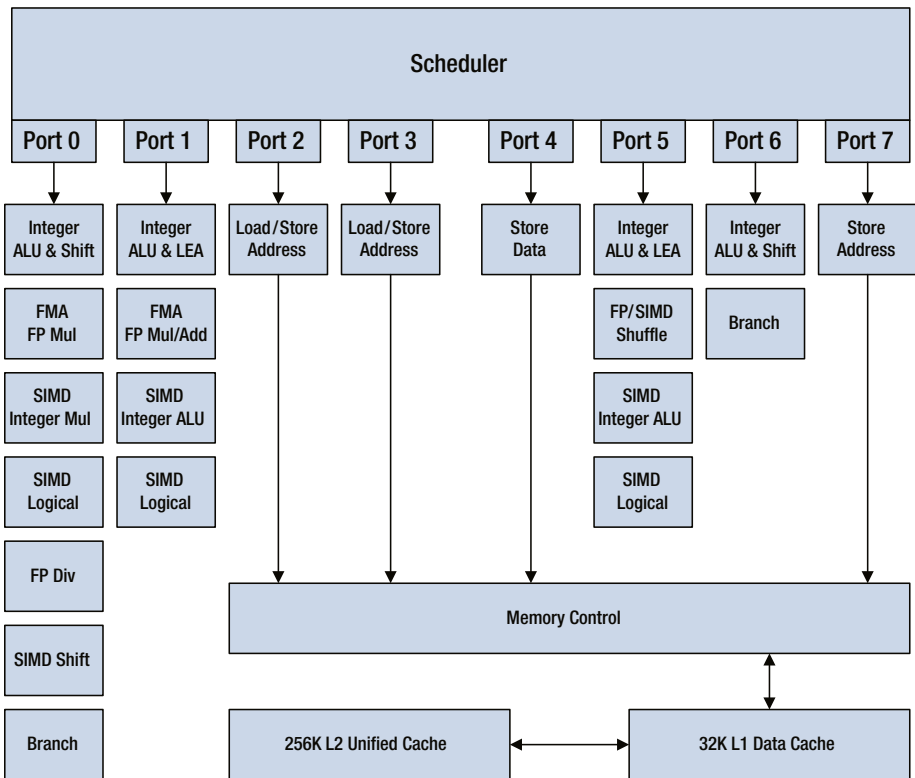

Figure 21-3. Haswell CPU core Execution Engine and its Execution Units

Each Execution Unit performs a specific calculation or operation. For example, the Integer ALU & Shift Execution Units carry out integer arithmetic and shift operations. The SIMD Integer ALU Execution Units are designed to perform SIMD integer arithmetic. Note that the Execution Engine contains multiple instances of select Execution Units. This allows the Execution Engine to simultaneously execute multiple instances of certain micro-ops in parallel. For example, the Execution Engine can concurrently perform three separate SIMD logical operations in parallel using the SIMD Logical Execution Units.

A Haswell Scheduler can dispatch a maximum of eight micro-ops per cycle (one per port) to the Execution Engine. The out-of-order engine, which includes the Scheduler, Execution Engine, and Retire Unit, supports up to 192 “in-flight” (or coexistent) micro-ops. Table 21-1 show key buffers sizes for recent Intel microarchitectures.

Table 21-1. Comparison of Key Microarchitecture Buffer Sizes

Parameter	Nehalem	Sandy Bridge	Haswell
Dispatch Ports	6	6	8
In-Flight Micro-Ops	128	168	192
In-Flight Loads	48	64	72
In-Flight Stores	32	36	42
Scheduler Entries	36	54	60

Optimizing Assembly Language Code

This section discusses some straightforward programming techniques that you can use to optimize the performance of x86 assembly language code. These techniques are recommended for use in code that targets recent Intel microarchitectures, including Haswell, Sandy Bridge, and Nehalem. Most of them are also appropriate for use in code that will execute on an earlier microarchitecture. The optimization techniques and ancillary guidelines are organized into five generic categories:

- Basic optimizations
- Floating-point arithmetic
- Program branches
- Data alignment
- SIMD techniques

It is important to keep in mind that all of the ensuing optimization techniques must be applied in a prudent manner. For example, it makes little sense to add extra `push` and `pop` instructions in order to avoid using a non-recommended instruction form only once. Moreover, none of the optimization techniques described in this chapter will remedy an inappropriate or poorly designed algorithm. The *Intel 64 and IA-32 Architectures Optimization Reference Manual* contains additional information about the optimization techniques discussed in this section.

Basic Optimizations

The following list contains a number of basic optimization techniques that are often used to improve the performance of x86 assembly language code:

- Use the `test` instruction instead of the `cmp` instruction whenever possible.
- Avoid using the memory-immediate forms of the `cmp` and `test` instructions (e.g., `cmp dword ptr [ebp+16],100` or `test byte ptr [r12],0fh`) whenever possible. Load the memory value into a register and use the register-immediate form of the `cmp` or `test` instruction (e.g., `mov eax,dword ptr [ebp+16]` followed by `cmp eax,100`).
- Use an `add` or `sub` instruction instead of an `inc` or `dec` instruction, especially in performance-critical loops. The latter two instructions do not update all of the status flags in EFLAGS, which is often slower.
- Use an `xor`, `sub`, `pxor`, `xorps`, and so on, instruction to zero a register instead of a data move instruction. For example, `xor eax,eax`, and `xorps xmm0,xmm0` are preferred over `mov eax,0` and `movaps xmm0,xmmword ptr [XmmZero]`.
- Avoid using 16-bit immediate values in instructions that require an operand-size prefix. Use an equivalent 8-bit or 32-bit immediate value instead. For example, use `mov edx,42` instead of `mov dx,42`.
- Unroll (or partially unroll) small loops that require a constant number of iterations.
- Load any memory values that are needed for multiple calculations into a register. If a memory value is needed only for a single calculation, use the register-memory form of the calculating instruction. Table 21-2 shows several examples.

Table 21-2. *Instruction Form Examples for Single and Multiple-Use Memory Values*

Register-Memory (Single-Use Data)	Move and Register-Register Form (Multiple-Use Data)
<code>add edx,dword ptr [x]</code>	<code>mov eax,dword ptr [x]</code> <code>add edx,eax</code>
<code>and rax,qword ptr [rbx+16]</code>	<code>mov rcx,[rbx+16]</code> <code>and rax,rcx</code>
<code>cmp ecx,dword ptr [n]</code>	<code>mov eax,dword ptr [n]</code> <code>cmp ecx,eax</code>
<code>mulpd xmm0,xmmword ptr [rdx]</code>	<code>movapd xmm1,xmmword ptr [rdx]</code> <code>mulpd xmm0,xmm1</code>

X86-64 code can benefit from the following optimization techniques:

- Use 32-bit general-purpose registers and instruction forms when working with 32-bit wide data values.
- Favor use of general-purpose registers EAX, EBX, ECX, EDX, ESI, and EDI before registers R8D-R15D when manipulating 32-bit wide data values. The instruction encodings for the latter register group require an extra byte.
- Exploit the additional general-purpose and SIMD registers in order to minimize data dependencies and register spills (a register spill occurs when a program must temporarily save the contents of a register to memory in order to free up the register for other calculations).
- Use the two- or three-operand form of the `imul` instruction to multiply two 64-bit integers if the full 128-bit product is not needed.

Floating-Point Arithmetic

The following guidelines should be observed when coding assembly language functions that employ floating-point arithmetic:

- Use the scalar floating-point instructions of x86-SSE or x86-AVX instead of the x87 FPU in new code.
- Avoid arithmetic underflows and denormal values during arithmetic calculations whenever possible.
- Avoid using denormalized floating-point constants.
- If excessive arithmetic underflows are expected, consider enabling the flush-to-zero (`MXCSR.FZ`) and denormals-are-zero (`MXCSR.DAZ`) modes. See Chapter 7, “Streaming SIMD Extensions” for more information regarding the proper use of these modes.

Program Branches

Program branch instructions, such as `jmp`, `call`, and `ret`, are potentially time-consuming operations to perform since they can affect the contents of the front-end pipelines and internal caches. The conditional jump instruction `jcc` is also a performance concern given its frequency of use. The following optimization techniques can be employed to minimize the adverse performance effects of branch instructions and improve the accuracy of the Branch Prediction Unit:

- Organize code to minimize necessary branch instructions.
- Use the `setcc` and `cmovcc` instructions to eliminate unpredictable data-dependent branches.

- Align branch targets in performance-critical loops to 16-byte boundaries.
- Move conditional code that is unlikely to execute (e.g. error-handling code) to another program section or memory page.

The Branch Prediction Unit employs both static and dynamic techniques when predicting the target of a branch instruction. Incorrect branch predictions can be minimized if blocks of code containing conditional jump instructions are arranged such that they're consistent with the Branch Prediction Unit's static prediction algorithm:

- Use forward conditional jumps when the fall-through code is likely to be executed.
- Use backward conditional jumps when the fall-through code is unlikely to be executed.

The forward conditional jump method is frequently used in blocks of code that perform function argument validation. The backward conditional jump technique can be employed at the bottom of a program loop code block following a counter update or other loop-terminating test decision. Listing 21-1 contains a short assembly language function that illustrates these practices in greater detail.

Listing 21-1. Use of conditional jump instructions that correspond to the static branch prediction algorithm

```
.model flat,c
.code

; extern "C" bool CalcResult_(double* des, const double* src, int n);

CalcResult_ proc
    push ebp
    mov ebp,esp
    push esi
    push edi

; Forward conditional jumps are used in this code block since
; the fall-through cases are more likely to occur.
    mov edi,[ebp+8]           ;edi = des
    test edi,0fh
    jnz Error                ;jump if des is not aligned
    mov esi,[ebp+12]         ;esi =src
    test esi,0fh
    jnz Error                ;jump if src is not aligned
    mov ecx,[ebp+16]         ;ecx = n
    cmp ecx,2
    jl Error                 ;jump if n < 2
    test ecx,1
    jnz Error                ;jump if n % 2 != 0
```

```

; Simple array processing loop
    xor eax,eax
@@:   movapd xmm0,xmmword ptr [esi+eax]
      mulpd xmm0,xmm0
      movapd xmmword ptr [edi+eax],xmm0

; A backward conditional jump is used in this code block since
; the fall-through case is less likely to occur.
    add eax,16
    sub ecx,2
    jnz @B

    mov eax,1
    pop edi
    pop esi
    pop ebp
    ret

; Error handling code, which is unlikely to execute.
Error: xor eax,eax
      pop edi
      pop esi
      pop ebp
      ret
CalcResult_ endp
      end

```

Data Alignment

It's been mentioned a number of times in this book, but the importance of using properly aligned data cannot be over emphasized. Programs that manipulate improperly aligned data are likely to trigger the processor into performing additional memory cycles and micro-op executions, which can negatively affect overall system performance. The following data alignment practices should be considered universal truths and always observed:

- Align multi-byte integer and floating-point values to their natural boundaries.
- Align 64-, 128-, and 256-bit wide packed data values to their proper boundaries.
- Pad data structures if necessary to ensure proper alignment.
- Use the appropriate compiler directives and library functions to align data items that are allocated in high-level code. For example, the `__declspec(align(n))` directive and `_aligned_malloc` function can be used to properly align data items allocated in a Visual C++ function.
- Give preference to aligned stores over aligned loads.

The following data arrangement techniques are also recommended:

- Align and position small arrays and short text strings in a data structure to avoid cache line splits.
- Evaluate the performance effects of different data layouts such as structure of arrays versus array of structures.

SIMD Techniques

The following techniques should be observed, when appropriate, by any function that uses the computational resources of x86-SSE or x86-AVX:

- Eliminate register dependencies in order to exploit multiple Execution Units in the Execution Engine.
- Use packed single-precision instead double-precision floating-point values.
- Load multiple-use memory operands and packed constants into a register.
- Perform packed data loads and stores using the aligned move instructions (e.g., `movdqa`, `movaps`, `movapd`, and so on).
- Process SIMD arrays using small data blocks in order to maximize reuse of resident cache data.
- Use data blends instead of data shuffles in x86-AVX code.
- Use the `vzeroupper` instruction when required to avoid x86-AVX to x86-SSE state transition penalties.
- Use the doubleword forms of the x86-AVX `vgather` instructions instead of the quadword forms. Perform any required gather operations well ahead of when the data is needed.

The following practices can be employed to improve the performance of certain algorithms that perform SIMD encoding and decoding operations:

- Use the non-temporal store instructions (e.g., `movntdqa`, `movntpd`, `movntps`, and so on) to minimize cache pollution.
- Use the data prefetch instructions (e.g., `prefetcht0`, `prefetchnta`, and so on) to notify the processor of expected-use data items.

Chapter 22 contains sample code that illustrates use of the non-temporal store and data prefetch instructions.

Summary

In this penultimate chapter, you examined the inner workings of a modern x86 processor, including multi-core composition and microarchitecture arrangement. You also learned some useful techniques that can be easily employed to improve the performance of x86 assembly language code. In the final chapter of this book, you'll study some sample code that expounds on the topics presented in this chapter.



Advanced Topics Programming

This chapter examines a couple of sample programs that illustrate some advanced x86 assembly language programming techniques. The first sample program explains how to accelerate the performance of a SIMD processing algorithm using non-temporal memory stores. The second sample program exemplifies use of software data prefetches to speed up linked list traversals. Both sample programs implement their respective algorithms using x86-32 and x86-64 assembly language functions in order to facilitate performance comparisons between the two execution environments.

Non-Temporal Memory Stores

From the perspective of a memory cache, data can be classified as temporal or non-temporal. Temporal data is any value that is accessed more than once within a short period of time. Examples of temporal data include the elements of an array or data structure that are referenced multiple times during execution of a program loop. It also includes the code bytes of a program. Non-temporal data is any value that is accessed once and not immediately reused. The destination arrays of many SIMD processing algorithms often contain non-temporal data.

Processor performance degrades if its memory caches contain excessive amounts of non-temporal data. This condition is commonly called cache pollution. Ideally, a processor's memory caches contain only temporal data since it makes little sense to cache items that are accessed only once. The x86-SSE instruction set includes several non-temporal memory store instructions that a program can use to minimize cache pollution.

The sample program of this section, which is called `NonTemporalStore`, illustrates use of the non-temporal memory store instruction `movntps` (Store Packed Single-Precision Floating-Point Values Using Non-Temporal Hint). It also compares the performance of this instruction to the standard `movaps` instruction. Listings 22-1, 22-2, and 22-3 contain the C++ and assembly language source code for the sample program `NonTemporalStore`.

Listing 22-1. NonTemporalStore.cpp

```

#include "stdafx.h"
#include "NonTemporalStore.h"
#include <math.h>
#include <malloc.h>
#include <stdlib.h>
#include <stddef.h>

bool CalcResultCpp(float* c, const float* a, const float* b, int n)
{
    if ((n <= 0) || ((n & 0x3) != 0))
        return false;

    if (((uintptr_t)a & 0xf) != 0)
        return false;
    if (((uintptr_t)b & 0xf) != 0)
        return false;
    if (((uintptr_t)c & 0xf) != 0)
        return false;

    for (int i = 0; i < n; i++)
        c[i] = sqrt(a[i] * a[i] + b[i] * b[i]);

    return true;
}

bool CompareResults(const float* c1, const float* c2a, const float* c2b,
int n, bool pf)
{
    const float epsilon = 1.0e-9f;
    bool compare_ok = true;

    for (int i = 0; i < n; i++)
    {
        if (pf)
            printf("%2d - %10.4f %10.4f %10.4f\n", i, c1[i], c2a[i],
c2b[i]);

        bool b1 = fabs(c1[i] - c2a[i]) > epsilon;
        bool b2 = fabs(c1[i] - c2b[i]) > epsilon;

        if (b1 || b2)
        {
            compare_ok = false;

```

```

        if (pf)
            printf("Compare error at index %2d: %f %f %f\n", i, c1[i],
c2a[i], c2b[i]);
    }
}

return compare_ok;
}

void NonTemporalStore(void)
{
    const int n = 16;
    const int align = 16;
    float* a = (float*)_aligned_malloc(n * sizeof(float), align);
    float* b = (float*)_aligned_malloc(n * sizeof(float), align);
    float* c1 = (float*)_aligned_malloc(n * sizeof(float), align);
    float* c2a = (float*)_aligned_malloc(n * sizeof(float), align);
    float* c2b = (float*)_aligned_malloc(n * sizeof(float), align);

    srand(67);
    for (int i = 0; i < n; i++)
    {
        a[i] = (float)(rand() % 100);
        b[i] = (float)(rand() % 100);
    }

    CalcResultCpp(c1, a, b, n);
    CalcResultA_(c2a, a, b, n);
    CalcResultB_(c2b, a, b, n);

#ifdef _WIN64
    const char* platform = "Win64";
#else
    const char* platform = "Win32";
#endif

    printf("Results for LinkedListPrefetch (platform = %s)\n", platform);
    bool rc = CompareResults(c1, c2a, c2b, n, true);

    if (rc)
        printf("Array compare OK\n");
    else
        printf("Array compare FAILED\n");

    _aligned_free(a);
    _aligned_free(b);
    _aligned_free(c1);
}

```

```

    _aligned_free(c2a);
    _aligned_free(c2b);
}

int _tmain(int argc, _TCHAR* argv[])
{
    NonTemporalStore();
    NonTemporalStoreTimed();
    return 0;
}

```

Listing 22-2. NonTemporalStore32_.asm

```

IFDEF ASMX86_32
    .model flat,c
    .code

; _CalcResult32 Macro
;
; The following macro contains a simple calculating loop that is used
; to compare performance of the movaps and movntps instructions.

_CalcResult32 macro MovInstr
    push ebp
    mov ebp,esp
    push ebx
    push edi

; Load and validate arguments
    mov edi,[ebp+8]                ;edi = c
    test edi,0fh
    jnz Error                      ;jump if c is not aligned
    mov ebx,[ebp+12]              ;ebx = a
    test ebx,0fh
    jnz Error                      ;jump if a is not aligned
    mov edx,[ebp+16]              ;edx = b
    test edx,0fh
    jnz Error                      ;jump if b is not aligned

    mov ecx,[ebp+20]              ;ecx = n
    test ecx,ecx
    jle Error                      ;jump if n <= 0
    test ecx,3
    jnz Error                      ;jump if n % 4 != 0

; Calculate c[i] = sqrt(a[i] * a[i] + b[i] * b[i])
    xor eax,eax                    ;eax = common array offset
    align 16

```

```

@@:    movaps xmm0,xmmword ptr [ebx+eax]    ;xmm0 = values from a[]
      movaps xmm1,xmmword ptr [edx+eax]    ;xmm1 = values from b[]
      mulps  xmm0,xmm0                      ;xmm0 = a[i] * a[i]
      mulps  xmm1,xmm1                      ;xmm1 = b[i] * b[i]
      addps  xmm0,xmm1                      ;xmm0 = sum
      sqrtps xmm0,xmm0                      ;xmm0 = final result
      MovInstr xmmword ptr [edi+eax],xmm0 ;save final values to c

      add  eax,16                            ;update offset
      sub  ecx,4                             ;update counter
      jnz  @B

      mov  eax,1                             ;set success return code
      pop  edi
      pop  ebx
      pop  ebp
      ret

Error: xor  eax,eax                          ;set error return code
      pop  ebx
      pop  ebp
      ret
      endm

;extern bool CalcResultA_(float* c, const float* a, const float* b, int n)
CalcResultA_ proc
    _CalcResult32 movaps
CalcResultA_ endp

;extern bool CalcResultB_(float* c, const float* a, const float* b, int n)
CalcResultB_ proc
    _CalcResult32 movntps
CalcResultB_ endp
ENDIF
end

```

Listing 22-3. NonTemporalStore64_.asm

```

IFDEF ASMX86_64
    .code

; _CalcResult64 Macro
;
; The following macro contains a simple calculating loop that is used
; to compare performance of the movaps and movntps instructions.

```

```

_CalcResult64 macro MovInstr
; Load and validate arguments
    test rcx,0fh
    jnz Error                ;jump if c is not aligned
    test rdx,0fh
    jnz Error                ;jump if a is not aligned
    test r8,0fh
    jnz Error                ;jump if b is not aligned

    test r9d,r9d
    jle Error                ;jump if n <= 0
    test r9d,3
    jnz Error                ;jump if n % 4 != 0

; Calculate c[i] = sqrt(a[i] * a[i] + b[i] * b[i])
    xor eax,eax              ;eax = common array offset
    align 16
@@:    movaps xmm0,xmmword ptr [rdx+rax] ;xmm0 = values from a[]
        movaps xmm1,xmmword ptr [r8+rax] ;xmm1 = values from b[]
        mulps xmm0,xmm0                ;xmm0 = a[i] * a[i]
        mulps xmm1,xmm1                ;xmm1 = b[i] * b[i]
        addps xmm0,xmm1                ;xmm0 = sum
        sqrtps xmm0,xmm0                ;xmm0 = final result
        MovInstr xmmword ptr [rcx+rax],xmm0 ;save final values to c

        add rax,16                      ;update offset
        sub r9d,4                        ;update counter
        jnz @B

        mov eax,1                        ;set success return code
        ret

Error:  xor eax,eax                      ;set error return code
        ret
        endm

;extern bool CalcResultA_(float* c, const float* a, const float* b, int n)
_CalcResultA_proc
_CalcResult64 movaps
_CalcResultA_endp

;extern bool CalcResultB_(float* c, const float* a, const float* b, int n)
_CalcResultB_proc
_CalcResult64 movntps
_CalcResultB_endp
ENDIF
end

```

Toward the top of the file `NonTemporalStore.cpp` (Listing 22-1) is a function named `CalcResultCpp`. This function computes a simple arithmetic value using the elements of two single-precision floating-point arrays (`a` and `b`). It then writes the result to destination array `c`. The assembly language functions used in this sample program compute the same result. The next function, `CompareResults`, is used to confirm equivalence between the various C++ and assembly language output arrays. The function `NonTemporalStore` allocates and initializes the test arrays. It then invokes the aforementioned function `CalcResultCpp`. This is followed by calls to the corresponding assembly language functions `CalcResultA_` and `CalcResultB_`, which are described later in this section. The output arrays of the three calculating functions are then compared for any discrepancies.

The sample program `NonTemporalStore` includes both x86-32 and x86-64 implementations of the calculating functions `CalcResultA_` and `CalcResultB_`. Listing 22-2 shows the assembly language source code for the x86-32 versions. The function definitions for `CalcResultA_` and `CalcResultB_` are shown near the bottom of the `NonTemporalStore32_.asm` file. These functions use a macro named `_CalcResult32`, which generates the calculating code. Note that each use of the macro `_CalcResult32` uses a different value for the move instruction parameter.

The macro `_CalcResult32` is defined near the top of the file `NonTemporalStore32_.asm`. Following argument validation is a simple block of instructions that calculates $c[i] = \sqrt{a[i] * a[i] + b[i] * b[i]}$ using x86-SSE packed single-precision floating-point arithmetic. The statement `MovInstr xmmword ptr [edi+eax],xmm0` saves the final result to the destination array `c` using either a `movaps` or `movntps` instruction depending on the value of macro parameter `MovInstr`. This means that the code executed by functions `CalcResultA_` and `CalcResultB_` is identical, except for the instruction that saves results to the destination array.

Listing 22-3 shows the source code for the assembly language file `NonTemporalStore64_.asm`. The organization and logic of the x86-64 implementations of `CalcResultA_` and `CalcResultB_` are similar to their x86-32 counterparts. The macro `_CalcResult64` also uses the same x86-SSE calculating instructions as the macro `_CalcResult32`.

Note that except for the end directive, all of the statements in the files `NonTemporalStore32_.asm` and `NonTemporalStore64_.asm` are grouped inside an assembler `IFDEF` directive. The MASM preprocessor symbols `ASM_X86_32` and `ASM_X86_64` are defined on the appropriate Visual C++ property pages for each execution platform. This enables the Visual C++ project for sample program `NonTemporalStore` to support builds of both Win32 and Win64 executables. Appendix A, which you can download from <http://www.apress.com/9781484200650>, contains additional information on how to configure a Visual C++ project for multiple executable targets.

Output 22-1 shows the results for the Win32 build sample program `NonTemporalStore`. The output of the Win64 build is identical except for the platform name and benchmark filename. Tables 22-1 and 22-2 show timing measurements for both execution environments and contain some interesting outcomes. For sample program `NonTemporalStore`, use of the `movntps` instruction on the Haswell-based i7-4770 and i7-4600U processors is significantly faster than the corresponding `movaps` instruction. The execution times for the Sandy Bridge-based i3-2310M are the same (keep in mind that the `movntps` instruction merely provides a hint to the processor and is not guaranteed

to improve performance). The considerable time differences between the x86-32 and x86-64 versions of the function `CalcResultCpp` are also curious. The reason for these numbers is that the 64-bit version of the Visual C++ compiler generated code that exploited x86-SSE SIMD floating-point arithmetic, whereas the 32-bit edition produced x86-SSE scalar floating-point code.

Output 22-1. Sample Program `NonTemporalStore`

Results for `NonTemporalStore` (platform = Win32)

```
0 - 87.2066 87.2066 87.2066
1 - 51.4781 51.4781 51.4781
2 - 44.1022 44.1022 44.1022
3 - 112.4144 112.4144 112.4144
4 - 16.5529 16.5529 16.5529
5 - 53.1507 53.1507 53.1507
6 - 96.1769 96.1769 96.1769
7 - 125.3196 125.3196 125.3196
8 - 91.5478 91.5478 91.5478
9 - 85.8021 85.8021 85.8021
10 - 63.6003 63.6003 63.6003
11 - 76.0066 76.0066 76.0066
12 - 67.1863 67.1863 67.1863
13 - 91.2853 91.2853 91.2853
14 - 96.3172 96.3172 96.3172
15 - 27.0185 27.0185 27.0185
```

Array compare OK

Benchmark times saved to file `__NonTemporalStore32.csv`

Table 22-1. Mean Execution Times (in Microseconds) for X86-32 Functions `CalcResultCpp`, `CalcResultA_`, and `CalcResultB_` ($n = 1,000,000$)

CPU	<code>CalcResultCpp</code>	<code>CalcResultA_(movaps)</code>	<code>CalcResultB_(movntps)</code>
Intel Core i7-4770	1864	572	468
Intel Core i7-4600U	2377	812	595
Intel Core i3-2310M	5145	1707	1702

Table 22-2. Mean Execution Times (in Microseconds) for X86-64 Functions *CalcResultCpp*, *CalcResultA_*, and *CalcResultB_* ($n = 1,000,000$)

CPU	CalcResultCpp	CalcResultA_(movaps)	CalcResultB_(movntps)
Intel Core i7-4770	585	572	468
Intel Core i7-4600U	776	768	583
Intel Core i3-2310M	1714	1707	1702

Data Prefetch

An application program can also use the prefetch (Prefetch Data Into Caches) instruction to improve the performance of certain algorithms. This instruction facilitates pre-loading of expected-use data into the cache hierarchy of a processor. There are two basic forms of the prefetch instruction. The first form (*prefetcht0*) pre-loads temporal data into all levels of the processor's cache hierarchy. The second form (*prefetchnta*) pre-loads non-temporal data into the L2 cache and is used to help minimize cache pollution. It is important to note that both forms of the prefetch instruction only provide a hint to the processor about the data that a program expects to use. A processor may choose to perform the prefetch operation or ignore the hint.

The prefetch instructions are suitable for use with a variety of data structures, including large arrays and linked lists. A linked list is sequentially-organized collection of nodes. Each node includes a data section and one or more pointers (or links) to its adjacent nodes. Figure 22-1 illustrates a simple linked list. Linked lists are useful since their size can grow or shrink (i.e. nodes can be added or deleted) depending on data storage requirements. One drawback of a linked list is that the nodes are usually not stored in a contiguously-allocated block of memory. This tends to increase access times when traversing a list.

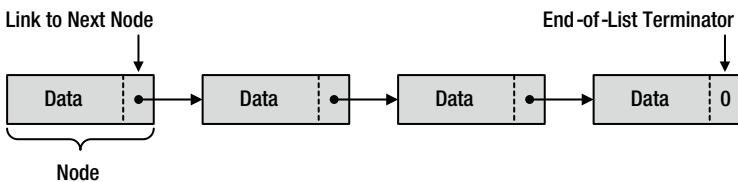

Figure 22-1. Simple linked list

The next sample program is named `LinkedListPrefetch`. This program contains x86-32 and x86-64 functions that perform linked list traversals both with and without the *prefetchnta* instruction. Listings 22-4 and 22-5 show the C++ and assembly language header files for sample program `LinkedListPrefetch`. The corresponding source code is shown in Listings 22-6 through 22-8.

Listing 22-4. LinkedListPrefetch.h

```

#pragma once
#include "MiscDefs.h"

// This structure must match the corresponding structure definition
// in LinkedListPrefetch.inc.
typedef struct llnode
{
    double ValA[4];
    double ValB[4];
    double ValC[4];
    double ValD[4];
    UInt8 FreeSpace[376];

    llnode* Link;

#ifdef _WIN64
    UInt8 Pad[4];
#endif

} Llnode;

extern void LlTraverseCpp(Llnode* p);
extern Llnode* LlCreate(int num_nodes);
extern bool LlCompare(int num_nodes, Llnode* l1, Llnode* l2, Llnode* l3, ←
int* node_fail);

extern "C" void LlTraverseA_(Llnode* p);
extern "C" void LlTraverseB_(Llnode* p);

extern void LinkedListPrefetchTimed(void);

```

Listing 22-5. LinkedListPrefetch.inc

```

; This structure must match the corresponding structure definition
; in LinkedListPrefetch.h

```

```

Llnode struct
ValA      real8 4 dup(?)
ValB      real8 4 dup(?)
ValC      real8 4 dup(?)
ValD      real8 4 dup(?)
FreeSpace byte 376 dup(?)

IFDEF ASM86_32
Link      dword ?
Pad       byte 4 dup(?)
ENDIF

```

```

IFDEF ASMX86_64
Link      qword ?
ENDIF

```

```

LlNode  ends

```

Listing 22-6. LinkedListPrefetch.cpp

```

#include "stdafx.h"
#include "LinkedListPrefetch.h"
#include <stdlib.h>
#include <math.h>
#include <stddef.h>

bool LlCompare(int num_nodes, LlNode* l1, LlNode* l2, LlNode* l3, int*
node_fail)
{
    const double epsilon = 1.0e-9;

    for (int i = 0; i < num_nodes; i++)
    {
        *node_fail = i;

        if ((l1 == NULL) || (l2 == NULL) || (l3 == NULL))
            return false;

        for (int j = 0; j < 4; j++)
        {
            bool b12_c = fabs(l1->ValC[j] - l2->ValC[j]) > epsilon;
            bool b13_c = fabs(l1->ValC[j] - l3->ValC[j]) > epsilon;
            if (b12_c || b13_c)
                return false;

            bool b12_d = fabs(l1->ValD[j] - l2->ValD[j]) > epsilon;
            bool b13_d = fabs(l1->ValD[j] - l3->ValD[j]) > epsilon;
            if (b12_d || b13_d)
                return false;
        }

        l1 = l1->Link;
        l2 = l2->Link;
        l3 = l3->Link;
    }

    *node_fail = -2;
    if ((l1 != NULL) || (l2 != NULL) || (l3 != NULL))
        return false;
}

```

```

    *node_fail = -1;
    return true;
}

void LlPrint(LlNode* p, FILE* fp, const char* msg)
{
    int i = 0;
    const char* fs = "%14.6lf %14.6lf %14.6lf %14.6lf\n";

    if (msg != NULL)
        fprintf(fp, "%s\n", msg);

    while (p != NULL)
    {
        fprintf(fp, "\nLlNode %d [0x%p]\n", i, p);
        fprintf(fp, "  ValA: ");
        fprintf(fp, fs, p->ValA[0], p->ValA[1], p->ValA[2], p->ValA[3]);

        fprintf(fp, "  ValB: ");
        fprintf(fp, fs, p->ValB[0], p->ValB[1], p->ValB[2], p->ValB[3]);

        fprintf(fp, "  ValC: ");
        fprintf(fp, fs, p->ValC[0], p->ValC[1], p->ValC[2], p->ValC[3]);

        fprintf(fp, "  ValD: ");
        fprintf(fp, fs, p->ValD[0], p->ValD[1], p->ValD[2], p->ValD[3]);

        i++;
        p = p->Link;
    }
}

LlNode* LlCreate(int num_nodes)
{
    LlNode* first = NULL;
    LlNode* last = NULL;

    srand(83);
    for (int i = 0; i < num_nodes; i++)
    {
        LlNode* p = (LlNode*)_aligned_malloc(sizeof(LlNode), 64);
        p->Link = NULL;
    }
}

```

```

    if (i == 0)
        first = last = p;
    else
    {
        last->Link = p;
        last = p;
    }

    for (int i = 0; i < 4; i++)
    {
        p->ValA[i] = rand() % 500 + 1;
        p->ValB[i] = rand() % 500 + 1;
        p->ValC[i] = 0;
        p->ValD[i] = 0;
    }
}

return first;
}

void LlTraverseCpp(LlNode* p)
{
    while (p != NULL)
    {
        for (int i = 0; i < 4; i++)
        {
            p->ValC[i] = sqrt(p->ValA[i] * p->ValA[i] + p->ValB[i] * ←
p->ValB[i]);
            p->ValD[i] = sqrt(p->ValA[i] / p->ValB[i] + p->ValB[i] / ←
p->ValA[i]);
        }
        p = p->Link;
    }
}

void LinkedListPrefetch(void)
{
    const int num_nodes = 8;
    LlNode* list1 = LlCreate(num_nodes);
    LlNode* list2a = LlCreate(num_nodes);
    LlNode* list2b = LlCreate(num_nodes);

#ifdef _WIN64
    const char* platform = "X86-64";
    size_t sizeof_ll_node = sizeof(LlNode);
    const char* fn = "__LinkedListPrefetchResults64.txt";

```

```

#else
    const char* platform = "X86-32";
    size_t sizeof_ll_node = sizeof(LlNode);
    const char* fn = "__LinkedListPrefetchResults32.txt";
#endif

    printf("\nResults for LinkedListPrefetch\n");
    printf("Platform target: %s\n", platform);
    printf("sizeof(LlNode): %d\n", sizeof_ll_node);
    printf("LlNode member offsets\n");
    printf(" ValA:          %d\n", offsetof(LlNode, ValA));
    printf(" ValB:          %d\n", offsetof(LlNode, ValB));
    printf(" ValC:          %d\n", offsetof(LlNode, ValC));
    printf(" ValD:          %d\n", offsetof(LlNode, ValD));
    printf(" FreeSpace:     %d\n", offsetof(LlNode, FreeSpace));
    printf(" Link:          %d\n", offsetof(LlNode, Link));
    printf("\n");

    LlTraverseCpp(list1);
    LlTraverseA_(list2a);
    LlTraverseB_(list2b);

    int node_fail;

    if (!LlCompare(num_nodes, list1, list2a, list2b, &node_fail))
        printf("\nLinked list compare FAILED - node_fail = %d\n",
node_fail);
    else
        printf("\nLinked list compare OK\n");

    FILE* fp;
    if (fopen_s(&fp, fn, "wt") == 0)
    {
        LlPrint(list1, fp, "\n----- list1 -----");
        LlPrint(list2a, fp, "\n ----- list2a -----");
        LlPrint(list2b, fp, "\n ----- list2b -----");
        fclose(fp);

        printf("\nLinked list results saved to file %s\n", fn);
    }
}

int _tmain(int argc, _TCHAR* argv[])
{
    LinkedListPrefetch();
    LinkedListPrefetchTimed();
    return 0;
}

```

Listing 22-7. LinkedListPrefetch32_.asm

```

IFDEF ASMX86_32
    include <LinkedListPrefetch.inc>
    .model flat,c
    .code

; Macro _llTraverse32
;
; The following macro generates linked list traversal code using the
; prefetchnta instruction if UsePrefetch is equal to 'Y'.

_llTraverse32 macro UsePrefetch
    mov eax,[esp+4]                ;eax = ptr to 1st node
    test eax,eax
    jz Done                        ;jump if end-of-list

    align 16

@@:    mov ecx,[eax+llNode.Link]    ;ecx = next node
        vmovapd ymm0,ymmword ptr [eax+llNode.ValA] ;ymm0 = ValA
        vmovapd ymm1,ymmword ptr [eax+llNode.ValB] ;ymm1 = ValB

IFIDNI <UsePrefetch>,<Y>
    mov edx,ecx
    test edx,edx                    ;is there another node?
    cmovz edx,eax                  ;avoid prefetch of NULL
    prefetchnta [edx]              ;prefetch start of next node
ENDIF

; Calculate ValC[i] = sqrt(ValA[i] * ValA[i] + ValB[i] * ValB[i])
    vmulpd ymm2,ymm0,ymm0          ;ymm2 = ValA * ValA
    vmulpd ymm3,ymm1,ymm1          ;ymm3 = ValB * ValB
    vaddpd ymm4,ymm2,ymm3          ;ymm4 = sums
    vsqrtpd ymm5,ymm4              ;ymm5 = square roots
    vmovntpd ymmword ptr [eax+llNode.ValC],ymm5 ;save result

; Calculate ValD[i] = sqrt(ValA[i] / ValB[i] + ValB[i] / ValA[i]);
    vdivpd ymm2,ymm0,ymm1          ;ymm2 = ValA / ValB
    vdivpd ymm3,ymm1,ymm0          ;ymm3 = ValB / ValA
    vaddpd ymm4,ymm2,ymm3          ;ymm4 = sums
    vsqrtpd ymm5,ymm4              ;ymm5 = square roots
    vmovntpd ymmword ptr [eax+llNode.ValD],ymm5 ;save result

    mov eax,ecx                    ;eax = ptr to next node
    test eax,eax
    jnz @B
    vzeroupper

```



```

Done:   ret
        endm

; extern "C" void LlTraverseA_(LlNode* first);
LlTraverseA_ proc
        _LlTraverse32 n
LlTraverseA_ endp

; extern "C" void LlTraverseB_(LlNode* first);
LlTraverseB_ proc
        _LlTraverse32 y
LlTraverseB_ endp

ENDIF
        end

```

Listing 22-8. LinkedListPrefetch64_.asm

```

IFDEF ASMX86_64
        include <LinkedListPrefetch.inc>
        .code

; Macro _LlTraverse64
;
; The following macro generates linked list traversal code using the
; prefetchnta instruction if UsePrefetch is equal to 'Y'.

_LlTraverse64 macro UsePrefetch
        mov rax,rcx                                ;rax = ptr to 1st node
        test rax,rax
        jz Done                                    ;jump if end-of-list

        align 16
@@::    mov rcx,[rax+LlNode.Link]                  ;rcx = next node
        vmovapd ymm0,ymmword ptr [rax+LlNode.ValA] ;ymm0 = ValA
        vmovapd ymm1,ymmword ptr [rax+LlNode.ValB] ;ymm1 = ValB

IFDEFI <UsePrefetch>,<Y>
        mov rdx,rcx
        test rdx,rdx                               ;is there another node?
        cmovz rdx,rax                              ;avoid prefetch of NULL
        prefetchnta [rdx]                          ;prefetch start of next node
ENDIF

ENDIF

; Calculate ValC[i] = sqrt(ValA[i] * ValA[i] + ValB[i] * ValB[i])
        vmulpd ymm2,ymm0,ymm0                      ;ymm2 = ValA * ValA
        vmulpd ymm3,ymm1,ymm1                      ;ymm3 = ValB * ValB
        vaddpd ymm4,ymm2,ymm3                      ;ymm4 = sums

```

```

vsqrtpd ymm5,ymm4                                ;ymm5 = square roots
vmovntpd ymmword ptr [rax+LLNode.ValC],ymm5 ;save result

; Calculate ValD[i] = sqrt(ValA[i] / ValB[i] + ValB[i] / ValA[i]);
vdivpd ymm2,ymm0,ymm1                             ;ymm2 = ValA / ValB
vdivpd ymm3,ymm1,ymm0                             ;ymm3 = ValB / ValA
vaddpd ymm4,ymm2,ymm3                             ;ymm4 = sums
vsqrtpd ymm5,ymm4                                ;ymm5 = square roots
vmovntpd ymmword ptr [rax+LLNode.ValD],ymm5 ;save result

mov rax,rcx                                       ;rax = ptr to next node
test rax,rax
jnz @B
vzeroupper

Done:  ret
      endm

; extern "C" void LLTraverseA_(LLNode* first);
LLTraverseA_ proc
    _LLTraverse64 n
LLTraverseA_ endp

; extern "C" void LLTraverseB_(LLNode* first);
LLTraverseB_ proc
    _LLTraverse64 y
LLTraverseB_ endp

ENDIF
end

```

The header file `LinkedListPrefetch.h` (Listing 22-4) contains the declaration for the C++ structure `LLNode`. The sample program `LinkedListPrefetch` uses this structure to construct linked lists of test data. Structure members `ValA` through `ValD` hold the data values that are manipulated by the linked list traversal functions. The member `FreeSpace` is included to increase the size of `LLNode` for demonstration purposes since prefetching works best with large data structures. A real-world implementation of the data structure `LLNode` could use this space for additional data items. The final member of `LLNode` is a pointer named `Link`, which points to the next `LLNode` structure in a linked list. Note that the Win32 version of `LLNode` includes an extra four-byte member named `Pad` in order to maintain structure size equivalence between the 32-bit and 64-bit executables. Listing 22-5 shows the corresponding declaration of the assembly language implementation of `LLNode`.

Near the top of the file `LinkedListPrefetch.cpp` (Listing 22-6) is an ancillary function named `LLCompare` that compares linked lists manipulated by the sample program for data equivalence. This is followed by another ancillary function named

`LLPrint` that prints the data members of a linked list to the specified `FILE` stream. The function `LLCreate` constructs a linked list that contains `num_nodes` instances of the data structure `LLNode`. Note that each `LLNode` is allocated on a 64-byte boundary in order to avoid cache line splits of the data arrays. The function `LLTraverse` contains code that traverses the designated linked list and performs the required calculations using the data arrays of each `LLNode` in a list. Finally, the function `LinkedListPrefetch` contains code that constructs the test linked lists. It then calls the C++ and assembly language traversal functions `LLTraverseCpp`, `LLTraverseA_`, and `LLTraverseB_`.

The assembly language files `LinkedListPrefetch32_.asm` (Listing 22-7) and `LinkedListPrefetch64_.asm` (Listing 22-8) contain the 32-bit and 64-bit implementations of the linked list traversal functions `LLTraverseA_` and `LLTraverseB_`. These functions, which are defined near the bottom of their respective files, use macros named `_LLTraverse32` or `_LLTraverse64` to generate the necessary code. Both of these macros require a single parameter that specifies whether the traversal code should include a `prefetchnta` instruction. Logically and structurally, the macros `_LLTraverse32` and `_LLTraverse64` are equivalent except for the pointer sizes. The discussions of the next two paragraphs will focus on the macro `_LLTraverse32`.

At the top of the linked list traversal loop, the data arrays `ValA` and `ValB` of the current node are loaded into registers `YMM0` and `YMM1`, respectively. A pointer to the next node is also loaded into register `ECX` (and conditionally into `EDX`). If the macro parameter `UsePrefetch` equals the character `Y`, a `prefetchnta [edx]` instruction is generated. This instruction non-temporally prefetches the start bytes of the next node, which includes data arrays `ValA` and `ValB`, into the L2 cache. Prior to execution of the `prefetchnta [edx]` instruction, `EDX` is tested in order to avoid performing a prefetch operation using a `NULL` memory address, which can degrade processor performance. It is also important to note that a program should never attempt to execute a prefetch instruction using a memory address that is owned by another program.

A prefetch instruction works best if the processor can carry out the requested memory operation in the background while the CPU core continues to execute instructions. The calculating portion of `_LLTraverse32` employs some irrelevant packed double-precision float-point arithmetic to simulate a time-consuming operation. The computed results are saved to the destination arrays `ValC` and `ValD` using `vmovntpd` instructions since these arrays are referenced only once.

Output 22-2 shows the results for sample program `LinkedListPrefetch`. Timing measurements for the Win32 and Win64 builds are shown in Tables 22-3 and 22-4, respectively. For sample program `LinkedListPrefetch`, use of the `prefetchnta` instruction yielded better performance on the Haswell-based processors, especially the i7-4770. It should be noted that any performance benefits provided by the prefetch instructions are highly dependent on data usage patterns and the underlying microarchitecture. According to the *Intel 64 and IA-32 Architectures Optimization Reference Manual*, the data prefetch instructions are “implementation specific.” This means that in order to maximize prefetch performance, an algorithm must be “tuned to each implementation” or microarchitecture. The aforementioned reference manual contains additional information regarding use of the data prefetch instructions.

Output 22-2. Sample Program LinkedListPrefetch

Results for LinkedListPrefetch

Platform target: X86-32

sizeof(LlNode): 512

LlNode member offsets

```
ValA:      0
ValB:     32
ValC:     64
ValD:     96
FreeSpace: 128
Link:    504
```

Linked list compare OK

Linked list results saved to file __LinkedListPrefetchResults32.txt

Benchmark times saved to file __LinkedListPrefetch32.csv

Table 22-3. Mean Execution Times (in Microseconds) for X86-32 Functions *LlTraverseCpp*, *LlTraverseA_*, and *LlTraverseB_* (*num_nodes* = 20,000)

CPU	LlTraverseCpp	LlTraverseA_	LlTraverseB_ (prefetchnta)
Intel Core i7-4770	1912	867	799
Intel Core i7-4600U	1911	969	955
Intel Core i3-2310M	3601	1676	1669

Table 22-4. Mean Execution Times (in Microseconds) for X86-64 Functions *LlTraverseCpp*, *LlTraverseA_*, and *LlTraverseB_* (*num_nodes* = 20,000)

CPU	LlTraverseCpp	LlTraverseA_	LlTraverseB_ (prefetchnta)
Intel Core i7-4770	1660	843	793
Intel Core i7-4600U	1645	902	879
Intel Core i3-2310M	3391	1676	1669

Summary

In this chapter, you learned a few details about the basics of non-temporal memory stores and the types of algorithms that may benefit from their use. You also learned how to use the x86's data prefetch instructions. The sample programs of this chapter should be regarded as mere primers to advanced x86 assembly language programming. You are encouraged to consult the references listed in Appendix C, which is available online at <http://www.apress.com/9781484200650>, for additional information regarding advanced x86 assembly language programming topics.

Index

■ A

acos function, 374

andn instruction, 347

Arrays

one-dimensional arrays

CalcArraySquares program, 58, 60

CalcArraySum program, 57

source code implementation, 55

two-dimensional arrays

CalcMatrixRowColSums, 62, 65

row-major ordering, 61

AVX, 327–328

AVX2, 328

AVX-512, 328

■ B

bextr instruction, 347

Blend instructions, 337

blsi instruction, 347

blsmask instruction, 347

blsr instruction, 347

Bonnell, 3

Branch Prediction Unit

backward conditional jump, 633

forward conditional jump, 632

Broadcast instructions, 336

Bulldozer microarchitecture, 3

bzhi instruction, 347

■ C

CalcLeastSquares program

code implementation, 124

fadd instructions, 129

formula, 128

slope-intercept denominator, 130

stack register, 129

statistical technique, 128

CalcMeanStdev program, 112, 116

code implementation, 112

ECX registers, 115

EDX registers, 115

fldz instruction, 115

formula, 115

FPU registers, 115

CalcMinMax program

code implementation, 116

stack register, 119

validation check, 118

CalcSphereAreaVolume program

code implementation, 108

flag status, 110

fmulp instruction, 111

formula, 109

f(u) comi (p) instructions, 110

stack register, 111

ConvertCoordinates program

code implementation, 120

formula, 122

polar coordinate, 122

PolarToRect_, 123

two-dimensional plane, 122

Core microarchitecture, 2

Correlation coefficient, 394

Correlation coefficient program

AvxPackedFloatingPoint

CorrCoef_.asm, 391

AvxPackedFloatingPoint

CorrCoef.cpp, 389, 394

program output, 396

Cpuid instruction

AvxCpuid_.asm, 444

AvxCpuid.cpp, 439

cvtps2pd instruction, 335

D

- Data blend, 453
 - AvxBlend_.asm, 455
 - AvxBlend.cpp, 453, 456
 - program output, 457
 - vblendvps instruction, 457
 - vpblendvb instruction, 457
 - vpblendw and vpblendd instructions, 457
- Data broadcast, 447
 - AvxBroadcast_.asm, 449, 452
 - AvxBroadcast.cpp, 448, 452
 - program output, 452
- Data gather, 463
 - AvxGather_.asm, 467–469
 - AvxGather.cpp, 464, 468
- Data-manipulation instructions, 447
 - data blend
 - AvxBlend_.asm, 455
 - AvxBlend.cpp, 453, 456
 - program output, 457
 - vpblendvb instruction, 457
 - vpblendw and vpblendd instructions, 457
 - data broadcast, 447
 - AvxBroadcast_.asm, 449, 452
 - AvxBroadcast.cpp, 448, 452
 - program output, 452
 - data gather, 463
 - AvxGather_.asm, 467–469
 - AvxGather.cpp, 464, 468
 - data permute
 - AvxPermute_.asm, 460, 462
 - AvxPermute.cpp, 458, 462
 - program output, 463
- Data permute
 - AvxPermute_.asm, 460, 462
 - AvxPermute.cpp, 458, 462
 - program output, 463
- Data prefetch, 645
- Data types, x86-32, 4
 - BCD values, 8
 - bit fields, 7
 - bit strings, 8
 - fundamental, 4
 - numerical, 5
 - packed, 6
 - strings, 7

E

- End-of-string (EOS) character, 303
- Extract and insert instructions, 338

F

- Feature extension instructions
 - fused-multiply-add group, 343
 - VFMAADD subgroup, 344
 - VFMADDSUB subgroup, 345
 - VFMSUBADD subgroup, 345
 - VFMSUB subgroup, 344
 - VFNMAADD subgroup, 346
 - VFNMSUB subgroup, 346
 - general-purpose register group, 346
 - half-precision floating-point group, 342
- Floating-point shuffle and word unpack operations, 334
- Fused-multiply-add (FMA) instructions, 343
 - VFMAADD subgroup, 344
 - VFMADDSUB subgroup, 345
 - VFMSUBADD subgroup, 345
 - VFMSUB subgroup, 344
 - VFNMAADD subgroup, 346
 - VFNMSUB subgroup, 346
- Fused-multiply-add programming, 470
 - AvxFma_.asm, 474
 - AvxFma.cpp, 471

G

- Gather instructions, 340
- General-purpose register instructions, 346, 482
 - enhanced bit manipulation
 - AvxGprBitManip.cpp, 486, 488
 - AvxGrpBitManip_.asm, 487, 489
 - program output, 489
 - stack contents, 489
 - flagless multiplication and bit shifts
 - AvxGprMulxShiftx_.asm, 483–484
 - AvxGprMulxShiftx.cpp, 482, 484
 - program output, 485

H

- Half-precision floating-point instructions, 342
- Haswell-based quad-core processor, 625
 - Execution Engine, 628
 - pipeline functionality, 626
 - allocate/rename block, 627
 - Branch Prediction Unit, 627
 - Instruction Decoders, 627
 - Instruction Fetch, 627
 - micro-fusion, 627
 - micro-ops, 627
 - Pre-Decode Unit, 627
- Haswell microarchitecture, 3
- Haswell processors, 328

I, J, K

- Image-processing
 - image-thresholding program, 425
 - AvxPackedInteger
 - Threshold_.asm, 429
 - AvxPackedInteger
 - Threshold.h, 426
 - pixel clipping
 - AvxPackedInteger
 - PixelClip_.asm, 420
 - AvxPackedInteger
 - PixelClip.cpp, 418, 423
 - AvxPackedInteger
 - PixelClip.h, 418, 422
 - definition, 417
 - instructions sequence, 423
 - mean execution times, 425
 - program output, 425
 - Image-thresholding program, 425
 - AvxPackedInteger
 - Threshold_.asm, 429
 - AvxPackedIntegerThreshold.h, 426
- Instruction pointer register (EIP), 13
- Instruction set
 - MMX technology
 - arithmetic group, 140
 - comparison group, 142
 - conversion group, 142
 - data transfer group, 139
 - insertion and extraction group, 144
 - local and shift group, 143
 - state and cache
 - control group, 145
 - unpack and shuffle group, 144

- x86-32
 - binary arithmetic group, 18
 - byte set and bit string
 - instruction group, 22
 - conditional codes, 16
 - control transfer group, 24
 - data comparison group, 20
 - data conversion group, 20
 - data transfer group, 18
 - flag manipulation group, 23
 - functional categories, 17
 - logical group, 21
 - miscellaneous group, 25
 - mnemonic suffixes, 16
 - purposes of, 15
 - rotate and shift group, 21
 - string instruction group, 22
 - test conditions, 16
- x87 floating-point unit (FPU), 95
 - arithmetic group, 96
 - constants group, 101
 - control group, 101
 - data-comparison group, 98
 - data transfer group, 95
 - transcendental group, 100
- IntegerMulDiv program, 32
 - epilog, 36
 - InvalidDivisor instruction, 35
 - push ebx instruction, 33
 - signed-integer division, 36
 - source code implementation, 32
- Intel 80386 microprocessor, 1
- Internal architecture, x86-32, 8
 - EFLAGS register, 11
 - EIP register, 13
 - general-purpose registers, 9
 - instruction operands, 13
 - memory addressing modes, 14
 - segment registers, 9

L

- lzcnt instruction, 348

M

- Masked move instructions, 339
- 4 × 4 Matrices
 - definition, 260
 - formula, 260
 - SsePackedFloatingPointMatrix4x4
 - program, 260

Matrix column means
 AvxPackedFloatingPoint
 ColMeans_.asm, 398
 AvxPackedFloatingPoint
 ColMeans.cpp, 396, 400
 col_means array updation, 401
 program output, 402

Microarchitectures, 2

MmxAddition program
 AddOpTable, 153
 cmp instruction, 154
 coding implementation, 149–153
 emms instruction, 155
 enumerators, 153
 MmxAddBytes function, 153
 MmxAddOp parameter, 153
 MmxAddWords function, 153
 MmxVal parameter, 153
 movq instruction, 154
 pshufw instruction, 154
 test cases, 155–156
 Visual C++, 154

MmxCalcMean program, 172, 178
 array element, 177
 coding implementation, 173–176
 MmxCalcMeanTimed, 176
 pshufw instruction, 177
 punpcklbw and punpckhbw
 instructions, 176

MmxCalcMinMax program
 C++ counterpart, 168
 coding implementation, 164–168
 MmxCalcMinMax.exe, 172
 MmxCalcMinMax
 Timed.cpp file, 170–171
 pmaxub instruction, 169
 pminub instruction, 168
 pointer, 168
 pshufw/pminub instruction, 169
 restrictions, 168
 standard library function, 168

MmxMultiplication
 coding implementation, 160–161
 MmxMulSignedWord, 162–163
 pmullw and pmulhw
 instructions, 162
 punpcklwd and punpckhwd
 instructions, 163

MmxShift program, 160
 coding implementation, 156–159
 enumerators, 159
 jmp instruction, 159

movq instruction, 159
 pshufw instruction, 159

MMX technology, 2, 133, 147
 and x87 FPU, 172
 data types, 137
 instruction set, 138
 arithmetic group, 139
 comparison group, 142
 conversion group, 142
 data transfer group, 139
 insertion and extraction group, 144
 local and shift group, 142
 state and cache control group, 145
 unpack and shuffle group, 143

integer array processing, 164

MiscDefs.h, 148

MmxVal.h, 148

packed integer addition, 147, 149, 164
 packed integer multiplication, 147, 160
 packed integer shifts, 156
 register set, 137
 SIMD processing, 133
 arithmetic operations, 134
 bit patterns, 134
 pmaxub instruction, 135
 wraparound *vs.* saturated
 arithmetic, 135

mulps instruction, 333

mulx instruction, 348

■ **N**

Nehalem microarchitecture, 2

Netburst, 2

New instructions
 blend group, 337
 broadcast group, 336
 extract and insert group, 338
 gather group, 340
 masked move group, 339
 permute group, 337
 variable bit shift group, 340

Non-temporal memory stores, 637

■ **O**

Optimization techniques, 623, 629
 basic optimizations, 630
 Branch Prediction Unit, 631
 data alignment, 633
 floating-point arithmetic, 631
 SMID techniques, 634

P

Packed floating-point arithmetic

- AvxPackedFloatingPoint
 - Arithmetic_.asm, 381, 383
 - AvxPackedFloatingPoint
 - Arithmetic.cpp, 379, 383
 - compare instruction, 244
 - conversions, 249
 - correlation coefficient
 - AvxPackedFloatingPoint
 - CorrCoef_.asm, 391
 - AvxPackedFloatingPoint
 - CorrCoef.cpp, 389, 394
 - program output, 396
 - least squares, 254
 - matrix column means
 - AvxPackedFloatingPoint
 - ColMeans_.asm, 398
 - AvxPackedFloatingPointCol
 - Means.cpp, 396, 400
 - col_means array update, 401
 - program output, 402
 - operations, 238
 - program output, 384
 - ToString_ formatting
 - functions, 237
 - YmmVal.h, 378
- Packed floating-point compares
- AvxPackedFloatingPoint
 - Compare_.asm, 386, 388
 - AvxPackedFloatingPoint
 - Compare.cpp, 385, 387
 - program output, 388-389
- Packed integers
- arithmetic operations, 405
 - AvxPackedInteger
 - Arithmetic_.asm, 408
 - AvxPackedInteger
 - Arithmetic.cpp, 406
 - program output, 411
 - vpsllvd and vpsravd
 - instructions, 410
 - fundamentals, 273
 - histogram, 279
 - threshold, 288
 - unpack operations, 412
 - AvxPackedInteger
 - Unpack_.asm, 414-415
 - AvxPackedInteger
 - Unpack.cpp, 412, 415

- program output, 417
 - vpckssdw instruction, 416
 - vpunpckldq and vpunpckhdq
 - instructions, 415-416
- paddb instruction, 333
- pdep instruction, 348
- Permute instructions, 337
- pext instruction, 348
- Pixel clipping algorithm
 - AvxPackedInteger
 - PixelClip_.asm, 420
 - AvxPackedInteger
 - PixelClip.cpp, 418, 423
 - AvxPackedInteger
 - PixelClip.h, 418, 422
 - definition, 417
 - instructions sequence, 423
 - mean execution times, 425
 - sample program, 425

Q

Quark microarchitecture, 3

R

- rdrand instruction, 348
- Roots of quadratic equation, 360
 - AvxScalarFloatingPoint
 - QuadEqu_.asm, 363
 - AvxScalarFloatingPoint
 - QuadEqu.cpp, 361
 - program output, 367
 - root computation equations, 367
 - solution forms, 365
- roxr instruction, 348

S

- Sandy Bridge, 2
- sarx instruction, 349
- Scalar floating-point arithmetic, 351
 - AvxScalarFloatingPoint
 - Arithmetic_.asm, 352-353
 - AvxScalarFloatingPoint
 - Arithmetic.cpp, 352-353
 - compare instructions, 212
 - conversions, 217
 - operation, 207
 - parallelograms, 228
 - program output, 354

- Scalar floating-point arithmetic (*cont.*)
 - roots of quadratic equation, 360
 - AvxScalarFloatingPoint
 - QuadEqu_.asm, 363
 - AvxScalarFloatingPoint
 - QuadEqu.cpp, 361
 - program output, 367
 - root computation equations, 367
 - solution forms, 365
 - spheres, 225
 - spherical coordinates
 - acos function, 374
 - AvxScalarFloatingPoint
 - Spherical_.asm, 369, 374
 - AvxScalarFloatingPoint
 - Spherical.cpp, 368, 373
 - call sin and call cos
 - instructions, 375
 - program output, 375
 - rectangular coordinates, 373
 - three-dimensional
 - coordinate system, 372
- Scalar floating-point compares
 - AvxScalarFloatingPoint
 - Compare_.asm, 356
 - AvxScalarFloatingPoint
 - Compare.cpp, 355, 357
 - program output, 359–360
 - vcmpsd and vcmpss instructions, 358
- shlx instruction, 349
- shr instruction, 349
- Silvermont microarchitecture, 3
- Silvermont System on a Chip (SoC)
 - microarchitecture, 3
- Single instruction multiple
 - data (SIMD), 133, 563
 - AVX-64 execution environment
 - data types, 561
 - instruction set, 562
 - register set, 560
 - AVX-64 programming
 - ellipsoid calculations, 590
 - matrix inverse, 602
 - miscellaneous instructions, 617
 - RGB image processing, 595
 - processing algorithm
 - data prefetch, 645
 - non-temporal memory stores, 637
 - SSE-64 execution environment
 - data types, 559
 - instruction set, 559
 - register set, 557
 - SSE-64 programming
 - image conversion, 571
 - image histogram, 563
 - vector arrays, 580
- Spherical coordinates program
 - acos function, 374
 - AvxScalarFloatingPoint
 - Spherical_.asm, 369, 374
 - AvxScalarFloatingPoint
 - Spherical.cpp, 368, 373
 - call sin and call cos instructions, 375
 - program output, 375
 - rectangular coordinates, 373
 - three-dimensional coordinate
 - system, 372
- SsePackedFloatingPoint
 - Arithmetic.program
 - coding implementation, 238
 - movaps and movapd, 243
 - SsePackedFpMath32_ and
 - SsePackedFp
 - Math64_functions, 243
 - XmmVal instances, 243
- SsePackedFloatingPointCompare
 - program, 248
 - cmpps and cmppd instructions, 244
 - coding implementation, 245–247
- SsePackedFloatingPointConversions
 - program
 - coding implementation, 249–252
 - cvtps2pd instruction, 253
- SsePackedFloatingPointLeastSquares
 - program
 - coding implementation, 254
 - _tmain function, 258
 - xorpd instruction, 259
- SsePackedFloatingPointMatrix4x4
 - program, 260
- SsePackedIntegerFundamentals program
 - coding implementation, 273
 - pmulld instruction, 278
 - SsePiSubI32 function, 277
- SsePackedIntegerHistogram program
 - coding implementation, 279
 - grayscale image, 279
- SsePackedIntegerThreshold program, 288
- SseScalarFloatingPointArithmetic
 - program
 - andps instruction, 212
 - caller-supplied array, 211
 - coding implementation, 208–211
 - movss instruction, 211

SseScalarFloatingPointCompare program
 coding implementation, 213–215
 comiss and comisd instructions, 216
 single-precision and double-precision, 216
 SseSfpCompareFloat_ function, 217

SseScalarFloatingPointConversions program, 217–218

SseScalarFloatingPointParallelograms program
 coding implementation, 228
 cos function, 234
 formulas, 234
 illustration of, 233
 sin function, 234
 sub esp,8 statement, 234
 transcendental instructions, 234

SseScalarFloatingPointSpheres program, 225
 coding implementation, 225–226
 mulsd instruction, 227
 xorpd instruction, 227

SseTextStringCalcLength program, 311
 coding implementation, 312
 pcmpestri instruction, 315
 strlen function, 315

SseTextStringReplaceChar program, 324
 coding implementation, 316
 EOS terminator byte, 322
 pcmpistrm xmm1,xmm2,40h instruction, 322
 popcnt edx,edx instruction, 322
 pshufb xmm6,xmm5 instruction, 322

State transition penalties, 336

Streaming SIMD Extension (SSE), 179

Strings
 CompareArrays
 repe cmpsd, 83
 results for, 83
 source code implementation, 80
 test instruction, 83

ConcatStrings
 declaration statement, 79
 des_index, 79
 drawbacks, 76
 rep movsw, 80
 repne scasw, 80

counting characters
 CountChars program, 76
 search character, 75
 source code implementation, 74
 text string, 75

ReverseArray
 parameters, 85
 pushfd and popfd, 85
 results for, 86
 source code implementation, 83

T, U

TemperatureConversions program, 104, 107
 code implementation, 104
 .const directive, 106
 fld instruction, 106
 floating-point value, 107
 formula, 106
 memory operands, 107
 real8 directive, 106
 stack register, 106

Text string, 303
 fundamentals
 EOS character, 303
 explicit/implicit length, 304
 IntRes1 algorithm, 310
 pcmpestri instruction, 304
 pcmpestrm instruction, 304
 pcmpestri instruction, 309–310
 pcmpestrm instruction, 307–308
 pcmpestrX flow diagram, 305–306
 processor exception, 311
 length calculation, 311
 replace characters, 316
 tzcnt instruction, 349

V, W

vaddsd instruction, 335
 vaddss instruction, 334–335
 Variable bit shift instructions, 340
 vblendvps instruction, 457
 vbroadcastf128 instruction, 337
 vbroadcasti128 instruction, 337
 vbroadcastsd instruction, 337
 vbroadcastss instruction, 337
 vcmpps and vcmpps instructions, 358
 vcvtps2pd instruction, 335
 vdivps instruction, 333
 vextracti128 instruction, 339
 VFMADD instructions, 344
 VFMADDSUB instructions, 345
 VFMSUBADD instructions, 345
 VFMSUB instructions, 344
 VFNMADD instructions, 346

VFNMSUB instructions, 346
 vgatherdd instruction, 342
 vgatherd instruction, 341
 vgatherdpd instruction, 342
 vgatherdps instruction, 340, 342
 vgatherdq instruction, 342
 vgatherqd instruction, 342
 vgatherq instruction, 341
 vgatherqpd instruction, 342
 vgatherqps instruction, 342
 vgatherqq instruction, 342
 vinserti128 instruction, 339
 vmaskmovpd instruction, 339
 vmaskmovps instruction, 339
 vmulps instruction, 333
 vmulsd instruction, 334
 vpackssdw instruction, 416
 vpaddb instruction, 333
 vpbldd instruction, 337
 vpbldvb instruction, 457
 vpbldw and vpbldd instructions, 457
 vpbroadcastb instruction, 337
 vpbroadcastd instruction, 337
 vpbroadcastq instruction, 337
 vpbroadcastw instruction, 337
 vperm2f128 instruction, 338
 vperm2i128 instruction, 338
 vpermd instruction, 338
 vpermilpd instruction, 338
 vpermilps instruction, 338
 vpermpd instruction, 338
 vpermps instruction, 338
 vpermq instruction, 338
 vpmaskmovd instruction, 339
 vpmaskmovq instruction, 339
 vpsllvd and vpsravd instructions, 410
 vpsllvd instruction, 340
 vpsllvq instruction, 340
 vpsravd instruction, 340
 vpsrlvd instruction, 340
 vpsrlvq instruction, 340
 vpsubb instruction, 333
 vpunpckldq and vpunpckhdq instructions, 415–416
 vsqrtsd instruction, 335
 vsqrts and vsqrtsd instructions, 335
 vsqrts instruction, 335
 vsubpd instruction, 333
 vzeroall instruction, 336
 vzeroupper instruction, 336

X, Y, Z

x86-32 assembly language programming, 27
 arrays, 54
 one-dimensional arrays, 55
 two-dimensional arrays, 60
 CalcSum, 28
 argument passing, 28
 function epilogs, 31
 function prologs, 31
 MASM directives, 30
 stack-related operations, 28
 calling convention
 CalculateSums_, 39
 C++ and assemble language listings, 37
 LocalVars program, 37
 prolog and epilog, 41
 results for, 41
 stack organization, 40
 condition codes, 49
 _min and _max macros, 53
 results for, 53
 setcc instruction, 54
 SignedMinA_ and SignedMaxA_, 53
 source code implementation, 49
 integer addition
 extern directive, 48
 register AX, 48
 results for, 49
 source code implementation, 46
 IntegerMulDiv, 32
 memory addressing modes, 41
 .const directive, 44
 drawbacks, 46
 hardware features, 46
 MemoryAddressing_ function, 44
 MemoryOperands_ function, 44
 results for, 45
 source code implementation, 41
 strings (*see also* Strings)
 CompareArrays, 80
 ConcatStrings, 76
 counting characters, 74
 ReverseArray, 83
 structures, 67
 dynamic structure creation, 70
 simple structures, 67
 Visual Studio project, 28

- x86-32 core architecture, 1
 - data types
 - BCD values, 8
 - bit fields, 7
 - bit strings, 8
 - fundamental, 4
 - numerical, 5
 - packed, 6
 - strings, 7
 - history of, 1
 - instruction set
 - binary arithmetic group, 18
 - byte set and bit string
 - instruction group, 22
 - conditional codes, 16
 - control transfer group, 24
 - data comparison group, 20
 - data conversion group, 20
 - data transfer group, 18
 - flag manipulation group, 23
 - functional categories, 17
 - logical group, 21
 - miscellaneous group, 25
 - mnemonic suffixes, 16
 - purposes of, 15
 - rotate and shift group, 21
 - string instruction group, 22
 - test conditions, 16
 - internal architecture, 8
 - EFLAGS register, 11
 - EIP register, 13
 - general-purpose registers, 9
 - instruction operands, 13
 - memory addressing modes, 14
 - segment registers, 9
- X86-64
 - instruction set, 499
 - deprecated resources, 502
 - invalid instructions, 500
 - new instructions, 500
 - operand sizes, 499
 - internal architecture, 491
 - general-purpose
 - registers, 493
 - instruction operands, 494
 - memory addressing modes, 495
 - RFLAGS register, 494
 - RIP register, 494
 - optimization techniques, 629
 - basic optimizations, 630
 - Branch Prediction Unit, 631
 - data alignment, 633
 - floating-point arithmetic, 631
 - SMID techniques, 634
 - processor microarchitecture, 623
 - Execution engine, 628
 - multi-core processor, 624
 - pipeline functionality, 626
 - SIMD (*see* Single instruction multiple data (SIMD))
 - multiple data (SIMD))
 - vs.* x86-32, 497
 - x86-64 assembly language
 - programming, 503
 - calling convention, 523
 - non-volatile registers, 528
 - non-volatile XMM registers, 533
 - prologs and epilogs, 539
 - stack frame pointer, 524
 - ConcatStrings, 533
 - FloatingPointArithmetic, 519
 - IntegerArithmetic, 505
 - argument registers, 508–509
 - IntegerAdd_ function, 509
 - IntegerDiv_ function, 510
 - IntegerMul_ function, 510
 - stack layout, 509
 - typedef statements, 508
 - uninitialized stack space, 508
 - IntegerOperands, 514
 - leaf functions, 504
 - MemoryAddressing, 511
 - non-leaf function, 504
 - overview, 503
 - two-dimensional array, 546
 - volatile and non-volatile
 - registers, 504
- X86-AVX data types, 329
- X86-AVX execution environment, 329
 - data types, 329
 - instruction syntax, 330
 - register set, 329
- X86-AVX feature extensions, 332
- X86-AVX instruction set, 333
 - cvtps2pd instruction, 335
 - feature extension instructions, 342
 - fused-multiply-add group, 343
 - general-purpose
 - register group, 346
 - half-precision floating-point group, 342
 - floating-point shuffle and word
 - unpack operations, 334

- X86-AVX instruction set (*cont.*)
 - mulps instruction, 333
 - new instructions
 - blend group, 337
 - broadcast group, 336
 - extract and insert group, 338
 - gather group, 340
 - masked move group, 339
 - permute group, 337
 - variable bit shift group, 340
 - padb instruction, 333
 - state transition penalties, 336
 - vaddsd instruction, 335
 - vaddss instruction, 334–335
 - vcvtps2pd instruction, 335
 - vdivps instruction, 333
 - vmulps instruction, 333
 - vmulsd instruction, 334
 - vpaddb instruction, 333
 - vpsubb instruction, 333
 - vsqrtsd instruction, 335
 - vsqrtss and vsqrtsd
 - instructions, 335
 - vsqrtss instruction, 335
 - vsubpd instruction, 333
 - vzeroall instruction, 336
 - vzeroupper instruction, 336
- X86-AVX instruction syntax, 330
- X86-AVX programming
 - cpuid instruction, 439
 - AvxCpuid_.asm, 444
 - AvxCpuid.cpp, 439
 - data-manipulation instructions, 447
 - data blend, 453
 - data broadcast, 447
 - data gather, 463
 - data permute, 458
 - fused-multiply-add
 - programming, 470
 - AvxFma_.asm, 474
 - AvxFma.cpp, 471
 - general-purpose register
 - instructions, 482
 - enhanced bit manipulation, 486
 - flagless multiplication
 - and bit shifts, 482
 - image processing
 - image-thresholding
 - program, 425
 - pixel clipping algorithm, 417
 - packed floating-point arithmetic
 - AvxPackedFloatingPoint
 - Arithmetic_.asm, 381, 383
 - AvxPackedFloatingPoint
 - Arithmetic.cpp, 379, 383
 - correlation coefficient, 389, 394
 - matrix column means, 396
 - program output, 384
 - YmmVal.h, 378
 - packed floating-point compares, 385
 - AvxPackedFloatingPoint
 - Compare_.asm, 386, 388
 - AvxPackedFloatingPoint
 - Compare.cpp, 385, 387
 - program output, 388–389
 - packed integer, 405
 - arithmetic operations, 405
 - unpack operations, 412
 - scalar floating-point arithmetic, 351
 - AvxScalarFloatingPoint
 - Arithmetic_.asm, 352–353
 - AvxScalarFloatingPoint
 - Arithmetic.cpp, 352–353
 - program output, 354
 - roots of quadratic equation, 360
 - spherical coordinates, 368
 - scalar floating-point compares, 355
 - AvxScalarFloatingPoint
 - Compare_.asm, 356
 - AvxScalarFloatingPoint
 - Compare.cpp, 355, 357
 - program output, 359–360
 - vcmps and vcmpss
 - instructions, 358
- X86-AVX register set, 329
- X86-AVX technologies, 327
 - AVX, 327–328
 - AVX2, 328
 - AVX-512, 328
 - Haswell Processors, 328
 - Sandy Bridge microarchitecture, 328
- X86-SSE, 179
 - evolution, 180
 - execution environment, 181
 - control-status register, 183
 - data types, 181
 - register set, 181
 - instruction set, 188, 197
 - cache control, 204
 - miscellaneous, 205

- non-temporal data transfer, 204
- packed floating-point
 - arithmetic, 193
- packed floating-point blend, 197
- packed floating-point
 - comparison, 195
- packed floating-point
 - conversion, 195
- packed floating-point
 - data transfer, 192
- packed floating-point logical, 198
- packed floating-point
 - shuffle and unpack, 196
- packed integer arithmetic, 199
- packed integer blend, 203
- packed integer
 - comparison, 200
- packed integer conversion, 201
- packed integer
 - data transfer, 199
- packed integer extensions, 198
- packed integer insertion and
 - extraction, 202
- packed integer shift, 203
- packed integer shuffle and
 - unpack, 202
- scalar floating-point
 - arithmetic, 190
- scalar floating-point
 - comparison, 191
- scalar floating-point
 - conversion, 191
- scalar floating-point
 - data transfer, 190
- scalar floating-point
 - text string processing, 204
- overview, 179
- processing techniques, 188
- X86-SSE programming
 - packed floating-point (*see* Packed floating-point arithmetic)
 - packed integers
 - fundamentals, 273
 - histogram, 279
 - threshold, 288
 - scalar floating-point (*see* Scalar floating-point arithmetic)
 - text string (*see* Text string)
- X86 Streaming SIMD Extensions.
 - See* X86-SSE
- x87 floating-point unit (FPU), 87, 103
 - architecture, 87
 - control register, 89
 - data registers, 88
 - encoding process, 93
 - compliant fields, 93
 - negative zero, 94
 - Not a Number (NaN), 94
 - positive zero, 94
 - exception handlers, 91
 - floating-point array, 112
 - floating-point values, 108
 - instruction set, 95
 - arithmetic group, 96
 - constants group, 101
 - control group, 101
 - data-comparison group, 98
 - data transfer group, 95
 - transcendental group, 100
 - memory operands, 92
 - parameters, 92
 - simple arithmetic, 104
 - stack register, 124
 - status register, 90
 - transcendental instructions, 120

Modern X86 Assembly Language Programming

32-bit, 64-bit, SSE, and AVX



Daniel Kusswurm

Apress®

Modern X86 Assembly Language Programming: 32-bit, 64-bit, SSE, and AVX

Copyright © 2014 by Daniel Kusswurm

This work is subject to copyright. All rights are reserved by the Publisher, whether the whole or part of the material is concerned, specifically the rights of translation, reprinting, reuse of illustrations, recitation, broadcasting, reproduction on microfilms or in any other physical way, and transmission or information storage and retrieval, electronic adaptation, computer software, or by similar or dissimilar methodology now known or hereafter developed. Exempted from this legal reservation are brief excerpts in connection with reviews or scholarly analysis or material supplied specifically for the purpose of being entered and executed on a computer system, for exclusive use by the purchaser of the work. Duplication of this publication or parts thereof is permitted only under the provisions of the Copyright Law of the Publisher's location, in its current version, and permission for use must always be obtained from Springer. Permissions for use may be obtained through RightsLink at the Copyright Clearance Center. Violations are liable to prosecution under the respective Copyright Law.

ISBN-13 (pbk): 978-1-4842-0065-0

ISBN-13 (electronic): 978-1-4842-0064-3

Trademarked names, logos, and images may appear in this book. Rather than use a trademark symbol with every occurrence of a trademarked name, logo, or image we use the names, logos, and images only in an editorial fashion and to the benefit of the trademark owner, with no intention of infringement of the trademark.

The use in this publication of trade names, trademarks, service marks, and similar terms, even if they are not identified as such, is not to be taken as an expression of opinion as to whether or not they are subject to proprietary rights.

While the advice and information in this book are believed to be true and accurate at the date of publication, neither the authors nor the editors nor the publisher can accept any legal responsibility for any errors or omissions that may be made. The publisher makes no warranty, express or implied, with respect to the material contained herein.

Managing Director: Welmoed Spahr

Lead Editors: Steve Weiss (Apress); Patrick Hauke (Intel)

Technical Reviewer: Paul Cohen

Editorial Board: Steve Anglin, Gary Cornell, Louise Corrigan, James T. DeWolf, Jonathan Gennick, Robert Hutchinson, Michelle Lowman, James Markham, Matthew Moodie, Jeff Olson, Jeffrey Pepper, Douglas Pundick, Ben Renow-Clarke, Gwenan Spearing, Matt Wade, Steve Weiss

Coordinating Editor: Melissa Maldonado

Copy Editor: Kezia Endsley

Compositor: SPi Global

Indexer: SPi Global

Artist: SPi Global

Cover Designer: Anna Ishchenko

Distributed to the book trade worldwide by Springer Science+Business Media New York, 233 Spring Street, 6th Floor, New York, NY 10013. Phone 1-800-SPRINGER, fax (201) 348-4505, e-mail orders-ny@springer-sbm.com, or visit www.springeronline.com. Apress Media, LLC is a California LLC and the sole member (owner) is Springer Science + Business Media Finance Inc (SSBM Finance Inc). SSBM Finance Inc is a **Delaware** corporation.

For information on translations, please e-mail rights@apress.com, or visit www.apress.com.

Apress and friends of ED books may be purchased in bulk for academic, corporate, or promotional use. eBook versions and licenses are also available for most titles. For more information, reference our Special Bulk Sales—eBook Licensing web page at www.apress.com/bulk-sales.

Any source code or other supplementary materials referenced by the author in this text is available to readers at www.apress.com. For detailed information about how to locate your book's source code, go to www.apress.com/source-code/.

This book is dedicated to those individuals who suffer the ravages of Alzheimer's disease and their unsung compassionate caregivers.

Contents

About the Author	xix
About the Technical Reviewer	xxi
Acknowledgments	xxiii
Introduction	xxv
■ Chapter 1: X86-32 Core Architecture	1
Historical Overview	1
Data Types	4
Fundamental Data Types	4
Numerical Data Types	5
Packed Data Types	6
Miscellaneous Data Types	7
Internal Architecture	8
Segment Registers	9
General-Purpose Registers	9
EFLAGS Register	11
Instruction Pointer	13
Instruction Operands	13
Memory Addressing Modes	14
Instruction Set Overview	15
Data Transfer	18
Binary Arithmetic	18
Data Comparison	20

Data Conversion	20
Logical	21
Rotate and Shift.....	21
Byte Set and Bit String	22
String.....	22
Flag Manipulation	23
Control Transfer	24
Miscellaneous.....	25
Summary.....	25
■ Chapter 2: X86-32 Core Programming	27
Getting Started	28
First Assembly Language Function.....	28
Integer Multiplication and Division	32
X86-32 Programming Fundamentals	36
Calling Convention.....	37
Memory Addressing Modes	41
Integer Addition	46
Condition Codes.....	49
Arrays.....	54
One-Dimensional Arrays.....	55
Two-Dimensional Arrays.....	60
Structures.....	67
Simple Structures.....	67
Dynamic Structure Creation	70
Strings.....	73
Counting Characters	74
String Concatenation	76

Comparing Arrays	80
Array Reversal	83
Summary	86
■ Chapter 3: X87 Floating-Point Unit	87
X87 FPU Core Architecture	87
Data Registers	88
X87 FPU Special-Purpose Registers	88
X87 FPU Operands and Encodings.....	91
X87 FPU Instruction Set.....	95
Data Transfer	95
Basic Arithmetic	96
Data Comparison	98
Transcendental	100
Constants.....	101
Control	101
Summary.....	102
■ Chapter 4: X87 FPU Programming.....	103
X87 FPU Programming Fundamentals.....	103
Simple Arithmetic	104
Floating-Point Compares	108
X87 FPU Advanced Programming.....	112
Floating-Point Arrays	112
Transcendental Instructions	120
Advanced Stack Usage	124
Summary.....	130

■ Chapter 5: MMX Technology	133
SIMD Processing Concepts	133
Wraparound vs. Saturated Arithmetic	135
MMX Execution Environment	137
MMX Instruction Set.....	138
Data Transfer	139
Arithmetic	139
Comparison	142
Conversion.....	142
Logical and Shift.....	142
Unpack and Shuffle	143
Insertion and Extraction.....	144
State and Cache Control	145
Summary.....	145
■ Chapter 6: MMX Technology Programming	147
MMX Programming Fundamentals.....	147
Packed Integer Addition.....	149
Packed Integer Shifts	156
Packed Integer Multiplication.....	160
MMX Advanced Programming	164
Integer Array Processing	164
Using MMX and the x87 FPU	172
Summary.....	178
■ Chapter 7: Streaming SIMD Extensions	179
X86-SSE Overview	179
X86-SSE Execution Environment.....	180
X86-SSE Register Set.....	181

X86-SSE Data Types	181
X86-SSE Control-Status Register	183
X86-SSE Processing Techniques	184
X86-SSE Instruction Set Overview	188
Scalar Floating-Point Data Transfer	190
Scalar Floating-Point Arithmetic.....	190
Scalar Floating-Point Comparison	191
Scalar Floating-Point Conversion	191
Packed Floating-Point Data Transfer	192
Packed Floating-Point Arithmetic	193
Packed Floating-Point Comparison	195
Packed Floating-Point Conversion.....	195
Packed Floating-Point Shuffle and Unpack	196
Packed Floating-Point Insertion and Extraction.....	197
Packed Floating-Point Blend	197
Packed Floating-Point Logical	198
Packed Integer Extensions	198
Packed Integer Data Transfer	199
Packed Integer Arithmetic	199
Packed Integer Comparison.....	200
Packed Integer Conversion.....	201
Packed Integer Shuffle and Unpack	202
Packed Integer Insertion and Extraction.....	202
Packed Integer Blend.....	203
Packed Integer Shift	203
Text String Processing	204
Non-Temporal Data Transfer and Cache Control.....	204
Miscellaneous.....	205
Summary.....	206

■ Chapter 8: X86-SSE programming – Scalar Floating-Point	207
Scalar Floating-Point Fundamentals	207
Scalar Floating-Point Arithmetic.....	207
Scalar Floating-Point Compare.....	212
Scalar Floating-Point Conversions.....	217
Advanced Scalar Floating-Point Programming	225
Scalar Floating-Point Spheres.....	225
Scalar Floating-Point Parallelograms	228
Summary.....	236
■ Chapter 9: X86-SSE Programming – Packed Floating-Point.....	237
Packed Floating-Point Fundamentals.....	237
Packed Floating-Point Arithmetic	238
Packed Floating-Point Compare	244
Packed Floating-Point Conversions	248
Advanced Packed Floating-Point Programming	254
Packed Floating-Point Least Squares.....	254
Packed Floating-Point 4 × 4 Matrices	260
Summary.....	271
■ Chapter 10: X86-SSE Programming – Packed Integers.....	273
Packed Integer Fundamentals.....	273
Advanced Packed Integer Programming	279
Packed Integer Histogram	279
Packed Integer Threshold	288
Summary.....	302

- **Chapter 11: X86-SSE Programming – Text Strings 303**
 - Text String Fundamentals..... 303
 - Text String Programming..... 311
 - Text String Calculate Length..... 311
 - Text String Replace Characters 316
 - Summary..... 325
- **Chapter 12: Advanced Vector Extensions (AVX) 327**
 - X86-AVX Overview..... 327
 - X86-AVX Execution Environment..... 329
 - X86-AVX Register Set 329
 - X86-AVX Data Types..... 329
 - X86-AVX Instruction Syntax 330
 - X86-AVX Feature Extensions 332
 - X86-AVX Instruction Set Overview 333
 - Promoted x86-SSE Instructions..... 333
 - New Instructions..... 336
 - Feature Extension Instructions 342
 - Summary..... 349
- **Chapter 13: X86-AVX Programming - Scalar Floating-Point 351**
 - Programming Fundamentals..... 351
 - Scalar Floating-Point Arithmetic..... 351
 - Scalar Floating-Point Compares 355
 - Advanced Programming..... 360
 - Roots of a Quadratic Equation 360
 - Spherical Coordinates 368
 - Summary..... 376

- **Chapter 14: X86-AVX Programming - Packed Floating-Point377**
 - Programming Fundamentals 377
 - Packed Floating-Point Arithmetic 378
 - Packed Floating-Point Compares 385
 - Advanced Programming 389
 - Correlation Coefficient 389
 - Matrix Column Means 396
 - Summary 403
- **Chapter 15: X86-AVX Programming - Packed Integers 405**
 - Packed Integer Fundamentals 405
 - Packed Integer Arithmetic 405
 - Packed Integer Unpack Operations 412
 - Advanced Programming 417
 - Image Pixel Clipping 417
 - Image Threshold Part Deux 425
 - Summary 437
- **Chapter 16: X86-AVX Programming - New Instructions 439**
 - Detecting Processor Features (CPUID) 439
 - Data-Manipulation Instructions 447
 - Data Broadcast 447
 - Data Blend 453
 - Data Permute 458
 - Data Gather 463
 - Fused-Multiply-Add Programming 470
 - General-Purpose Register Instructions 482
 - Flagless Multiplication and Bit Shifts 482
 - Enhanced Bit Manipulation 486
 - Summary 490

■ Chapter 17: X86-64 Core Architecture	491
Internal Architecture.....	491
General-Purpose Registers.....	492
RFLAGS Register.....	494
Instruction Pointer Register.....	494
Instruction Operands	494
Memory Addressing Modes	495
Differences Between X86-64 and X86-32.....	497
Instruction Set Overview	499
Basic Instruction Use.....	499
Invalid Instructions	500
New Instructions.....	500
Deprecated Resources	502
Summary.....	502
■ Chapter 18: X86-64 Core Programming	503
X86-64 Programming Fundamentals	503
Integer Arithmetic.....	504
Memory Addressing.....	511
Integer Operands.....	514
Floating-Point Arithmetic.....	519
X86-64 Calling Convention	523
Basic Stack Frames.....	524
Using Non-Volatile Registers	528
Using Non-Volatile XMM Registers.....	533
Macros for Prologs and Epilogs.....	539
X86-64 Arrays and Strings	546
Two-Dimensional Arrays.....	546
Strings	553
Summary.....	556

■ Chapter 19: X86-64 SIMD Architecture	557
X86-SSE-64 Execution Environment	557
X86-SSE-64 Register Set.....	557
X86-SSE-64 Data Types.....	559
X86-SSE-64 Instruction Set Overview.....	559
X86-AVX Execution Environment.....	560
X86-AVX-64 Register Set.....	560
X86-AVX-64 Data Types	561
X86-AVX-64 Instruction Set Overview	562
Summary.....	562
■ Chapter 20: X86-64 SIMD Programming	563
X86-SSE-64 Programming	563
Image Histogram	563
Image Conversion.....	571
Vector Arrays	580
X86-AVX-64 Programming	590
Ellipsoid Calculations.....	590
RGB Image Processing	595
Matrix Inverse.....	602
Miscellaneous Instructions.....	617
Summary.....	622
■ Chapter 21: Advanced Topics and Optimization Techniques	623
Processor Microarchitecture	623
Multi-Core Processor Overview.....	624
Microarchitecture Pipeline Functionality.....	626
Execution Engine	628

Optimizing Assembly Language Code	629
Basic Optimizations	630
Floating-Point Arithmetic	631
Program Branches	631
Data Alignment	633
SIMD Techniques	634
Summary	635
■ Chapter 22: Advanced Topics Programming	637
Non-Temporal Memory Stores	637
Data Prefetch.....	645
Summary.....	656
Index.....	657

About the Author



Daniel Kusswurm has over 30 years of professional experience as a software developer and computer scientist. During his career, he has developed innovative software for medical devices, scientific instruments, and image processing applications. On many of these projects, he successfully employed x86 assembly language to significantly improve the performance of computationally-intense algorithms or solve unique programming challenges. His educational background includes a BS in Electrical Engineering Technology from Northern Illinois University along with an MS and PhD in Computer Science from DePaul University.

About the Technical Reviewer



Paul Cohen joined Intel Corporation during the very early days of the x86 architecture, starting with the 8086, and retired from Intel after 26 years in sales/marketing/management. He is currently partnered with Douglas Technology Group, focusing on the creation of technology books on behalf of Intel and other corporations. Paul also teaches a class that transforms middle and high school students into real, confident entrepreneurs, in conjunction with the Young Entrepreneurs Academy (YEA) and is a Traffic Commissioner for the City of Beaverton, Oregon and on the Board of Directors of multiple non-profit organizations.

Acknowledgments

The production of a motion picture and the publication of a book are somewhat analogous. Movie trailers extol the performances of the lead actors. The front cover of a book trumpets the authors' names. Actors and authors ultimately receive public acclamation for their efforts. It is, however, impossible to produce a movie or publish a book without the dedication, expertise, and creativity of a professional behind-the-scenes team. This book is no exception.

I would like to thank Patrick Hauke for his valuable advice and championing of the book project during its conceptual stage. I am indebted to Steve Weiss for his editorial savvy and guidance through the book publishing jungle. I am extremely appreciative of Melissa Maldonado's efforts to keep me and everyone else focused and on schedule. Paul Cohen deserves kudos for his meticulous technical review and practical suggestions. Copy editor Kezia Endsley and proofreader Ed Kusswurm merit applause and recognition for their hard work and constructive feedback. I accept full responsibility for any remaining imperfections.

I would also like to thank Dhaneesh Kumar and the entire production staff at Apress for their contributions, Vyacheslav Klochkov and Mitch Bodart for their help in clarifying how to effectively use the FMA instructions, and my professional colleagues for their support and encouragement. Finally, I would like to recognize parental nodes Armin (RIP) and Mary along with sibling nodes Mary, Tom, Ed, and John for their inspiration during the writing of this book